

SQM5... Reversing Actuators, with Multiple Analog Control Input Signals

Product Description

Reversing actuator used to position flow control valves, butterfly valves, dampers, or any application requiring rotary motion with multiple analog input signals.

Product Numbers

SQM5x.xxxRxZx for 4 to 20 mA, 0 to 135 ohm and 0 to 10 Vdc input signals

Actuator Torque:	Max Shaft Torque:
SQM50.2... 90 in/lb	AGA58.1 200 in/lb
SQM50.3... 90 in/lb	AGA58.3 220 in/lb
SQM50.4... 140 in/lb	AGA58.4 270 in/lb
SQM53.4... 200 in/lb	AGA58.7 400 in/lb
SQM56.5... 310 in/lb	
SQM56.6... 400 in/lb	

SQM... motors allow torque on either end of the AGA58.3 and AGA58.4 shafts.

NOTE: For detailed information, see *Technical Instructions* (155-517P25).

Caution Notations

CAUTION:		Equipment damage may occur if you do not follow the procedures as specified.
-----------------	---	--

Installation

Cover Removal

Use a Phillips screwdriver to loosen the two screws on the actuator cover corners. See Figure 1.

Lift the screws and raise the cover. See Figure 2.

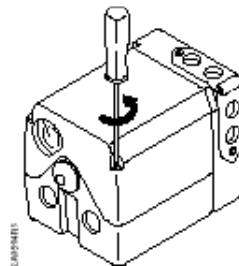

Figure 1.

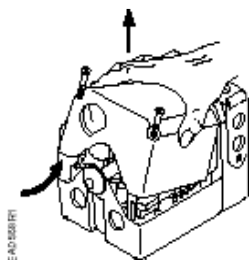

Figure 2.

Rotational Direction Verification

Actuator model numbers that end with "R" are factory configured for clockwise (cw), minimum to maximum rotation when facing the gear end of the actuator, or counterclockwise (ccw) rotation when facing the other end of the actuator. The gear end of the actuator is the side opposite of the visual position indicator.

Actuator Mounting

SQM5... actuators can be mounted in any orientation. Optional base mounting brackets are available.

SQM5... actuators can also be face mounted using self-tapping screws in combination with the various holes on the face of the actuator gear end.

Switch Adjustment

SQM5... actuators are factory-wired with Switch I (maximum), Switch II (fully closed/economy position) and Switch III (minimum/low-fire). The individual switch cams I, II, and III are factory set to 90°, 0° and 10°, respectively. See Figures 3 and 4.

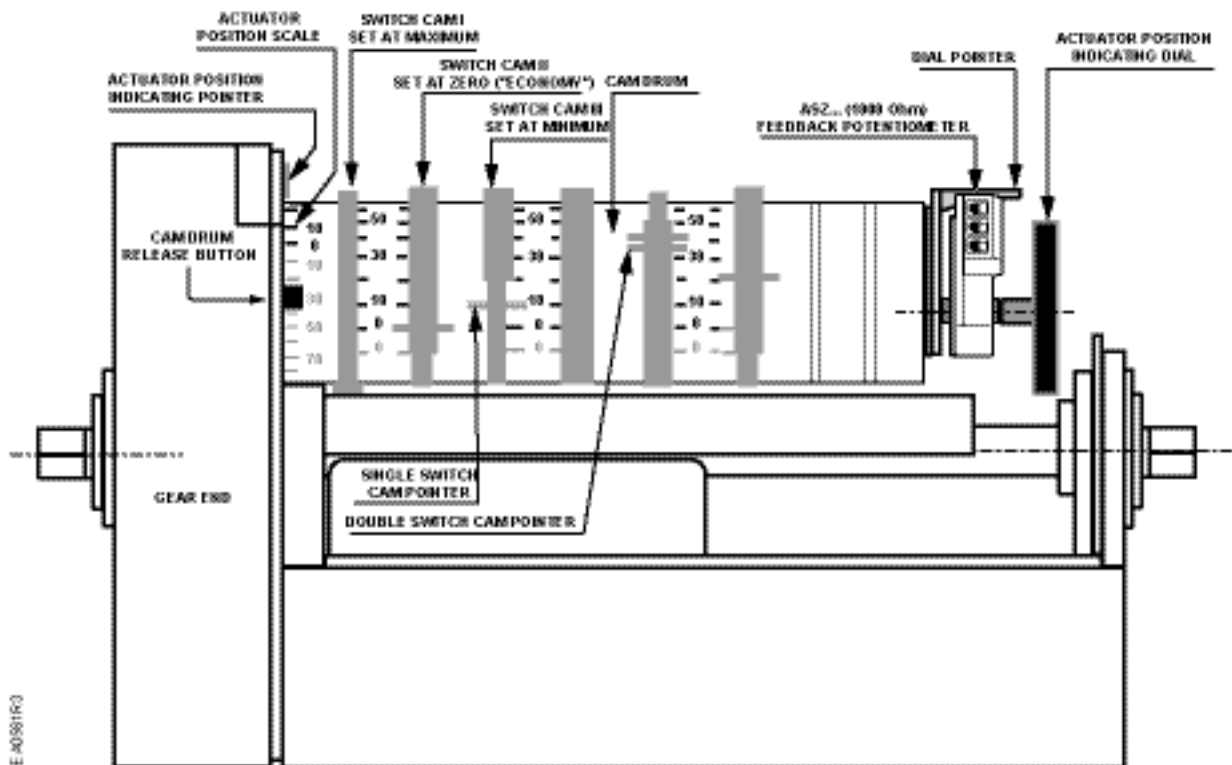

Figure 3. Component Identification on the Cam Drum Side of the SQM5...Actuator.

NOTE: The single switch cam pointers are used together with the black scales when configured for ccw operation.

The double switch cam pointers are used together with the red scales when configured for cw operation.

The individual switch cams can be adjusted by hand or with the use of the tool attached to the outside of the hinged switch terminal protection lid.

The adjustable range of the switches is limited by the potentiometer range.

SQM5x.xxxRxZ3 actuators have a 90° potentiometer and the switches must be adjusted between 0° and 90°.

SQM5x.xxxRxZ4 actuators have a 135° potentiometer and the switches must be adjusted between 0° and 135°.

Shaft Adjustment

The actuator shaft can be disengaged by pressing the silver shaft release button. The shaft release button is located above the grounding screw, under the hinged terminal protection cover, and to the right of the auto/manual switch. After pressing the shaft release button in and slightly upward, the shaft can

be manually rotated. After the shaft has been manually aligned to the closed position, re-engage the shaft by pushing the shaft release button downwards.

Cam Drum Adjustment

Once the shaft has been set to the closed position, the cam drum must be manually aligned by pressing and holding the black cam drum release button (see Figure 3). Rotate the cam drum until the "0" mark on the actuator position scale (left scale on the cam drum) is aligned with the gray actuator position indicating pointer.

Position Indicating Dial Adjustment

The actual position of the SQM5... actuator is indicated by the gray actuator position indicating pointer (see Figure 3). The position is also displayed by the indicating dial through the housing's window. Ensure that the actuator position indicating dial is aligned with the actuator position scale. If necessary, rotate the dial in the clockwise direction.



CAUTION:

Turning the dial in the counterclockwise direction may loosen the potentiometer locking screw.

Electrical Connection

SQM5... actuators are equipped with two removable conduit connection plates located on the upper corner of the gear housing. Each plate is provided with two threaded connections for 1/2-inch NPSM conduit connectors. The use of flexible stranded wire is recommended.

NOTE: SQM5... Actuators require a single-source, single-phase power supply.

Grounding

To avoid electro-magnetic interference, SQM5... actuators must be grounded. The ground screw is located to the right of the AUTO/MAN switch (below the shaft release button).



CAUTION:

Disconnect circuit board wire marked 51 during high voltage testing. Reconnect it to the grounding terminal after the test.

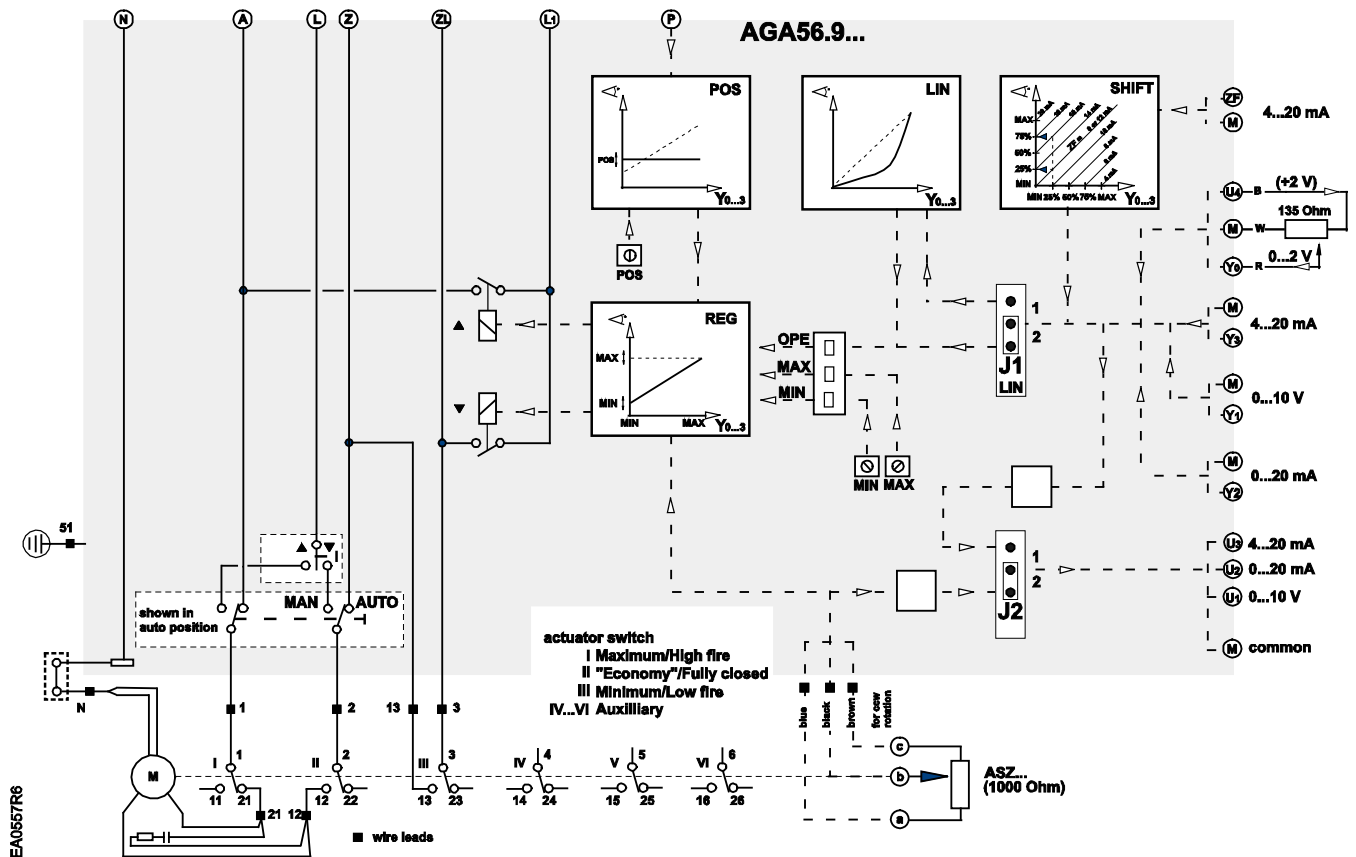

Figure 4. Basic Functional Diagram of AGA56.9...

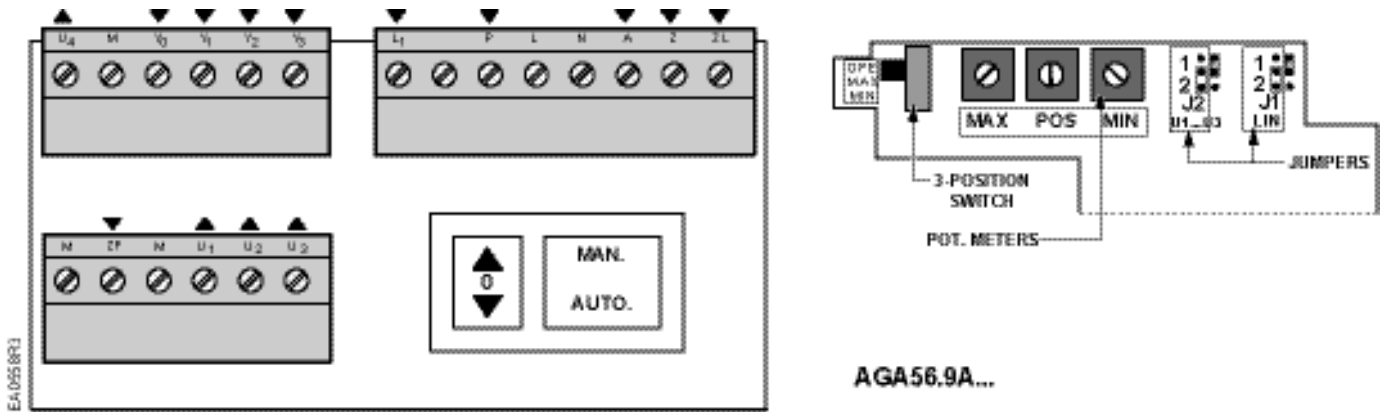

Figure 5. AGA56.9..... Terminal and Trim Potentiometer Boards.

Commissioning

Manual Operation

1. Set the AUTO/MAN switch in the MAN position.
2. Connect ground to the screw located below the shaft release button.
3. Connect neutral to terminal N.
4. Only terminal "L" must be powered to enable manual operation. The actuator can now be driven to the maximum (high fire) position (switch cam I) or the fully closed "economy position" (switch cam II) by using the toggle switch located to the left of the AUTO/MAN switch.

Automatic Operation

1. Set the AUTO/MAN switch in the AUTO position.
2. Connect ground to the screw located below the shaft release button.
3. Connect neutral to terminal N.
4. Connect line voltage at all times to terminal L to provide power to the electronic circuit board.
5. Connect line voltage to terminal L1 to provide power when modulating. Connect line voltage to Terminal L1 **only** after removing power on terminals A and Z (otherwise actuator damage may result).
6. Connect line voltage to terminal A to drive the actuator to the maximum (high fire purge) position. Once the maximum position is reached, terminal 11 (on switch I) will be energized to provide position feedback.
7. Connect power to terminal ZL to drive the actuator to the minimum (low-fire) position. Once the minimum

position is reached, terminal 23 (on switch III) will be energized to provide position feedback. Adjustment of switch III will determine the low-fire stop position. Switch III (low fire) must be set at a higher position than switch II (fully closed). Terminal ZL may be energized **only** after removing power from terminals A, Z, 13, and LR.

8. Connect line voltage to terminal Z to drive the actuator to the fully closed/economy position (switch II).



CAUTION:

Under no circumstances should terminals A and Z be powered at the same time. Actuator damage will occur.

9. Connect the input control signal wires to the appropriate terminals. See Figure 4.

Modulation Adjustment

The blue trim potentiometers allow the adjustment of the minimum (zero) and maximum (span) positions. The factory setting of the MIN trim potentiometer is rotated fully counter clockwise. The factory setting of the MAX trim potentiometer is rotated fully clockwise.

Zero Adjustment

Set the OPE/MAX/MIN slide switch to MIN (see Figure 5). The blue MIN trim potentiometer can now be gently adjusted to the required minimum position. Return the OPE/MAX/MIN slide switch to OPE for operation.

Span Adjustment

Set the OPE/MAX/MIN slide switch to MAX. The blue MAX trim potentiometer can now be gently adjusted to the required maximum position. Return the OPE/MAX/MIN slide switch to OPE for operation.

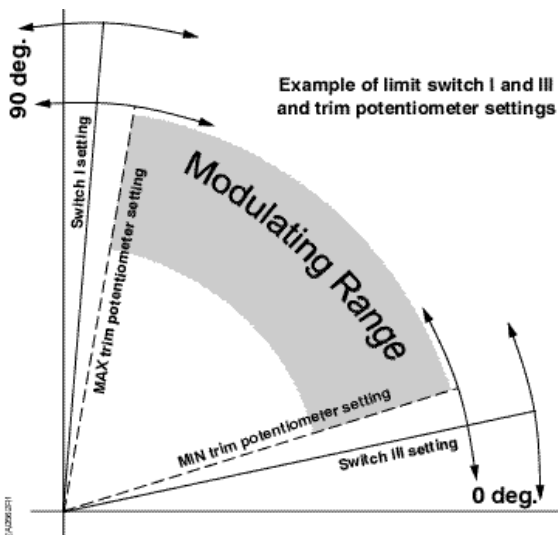

Figure 6. Switch Cam and Trim Potentiometer Setting.

NOTE: The actual minimum and maximum modulating range is determined by either the setting of the MIN and MAX trim potentiometers, or the setting of Switch Cam III (Minimum) and Switch Cam I (Maximum). The actuator can never modulate outside of the range set by switch cam I and III. If the MIN and MAX trim potentiometers are set outside the setting range of switch cams I and III, then the switch cam settings determine the modulating range (See Figure 6).

NOTE: Switch Cam I must not be set higher than:

- 90° when using feedback potentiometers ASZxx..803, or ASZxx.30;
- 135° when using feedback potentiometers ASZxx.833, or ASZxx.33

Electronic Linearization Function

Butterfly valves have non-linear flow characteristics. Near the fully closed position, a small change in the valve's position will produce a very large change in flow. Furthermore, near the fully open position, a large position change will produce a relatively small change in flow.

The linearization function is intended to minimize the initial steep flow curve characteristics of a typical butterfly valve. With jumper J1 in position 1 (upper position), the linearization function is enabled. Consequently, the actuator will make smaller rotational movements when subjected to lower input signals and larger rotational movements when subjected to higher input signals.

For example (based on a 90° modulating range), a change in input signal from 4 to 8 mA will cause a rotational movement of 11.25°. An equal change from 16 to 20 mA will cause a rotational movement of 45°. Thus, with the linearization function enabled, the change in flow is closely proportional to the change in input signal.

With jumper J1 in position 2 (lower position), the linearization function is disabled. When disabled, the rotational movement of the shaft is proportional to the input signal.

Input Signal Override

Line voltage to terminal P will drive the actuator to a pre-set adjustable position, overriding all modulating input signals. Use the potentiometer marked POS to adjust the override position to any setting within the setting range of switch cams I and III.

Parallel Operation

To configure the actuator for parallel operation, set the jumper J2 in position 1 (upper position). Input signals Y0, Y1, Y2 or Y3 are directly shunted to output signals U1, U2 and U3, respectively. All output signals are available regardless of which input signal is applied.

Master/Slave Operation

To configure the actuator for master/slave operation, set J2 in position 2 (lower position). The output signals U1, U2 and U3 reflect actual shaft position.

Split Ranging

AGA56.9... circuit boards have a modulating signal shift feature, which can be used for split ranging. If no signal is present on Y0, Y1, Y2 or Y3, the actuator will modulate through the full rotational range in response to a 12 to 20 mA signal applied at ZF. If a maximum signal is present on Y0, Y1, Y2, or Y3, then the actuator will modulate through the full rotational range in response to a 4 to 12 mA signal applied at ZF. (Maximum signal can be easily achieved by bridging terminals U4 and Y0.) See Figure 9.

NOTE: It is possible to configure the actuator for split range operation 12 to 4 mA and 20 to 12 mA. Consult your Combustion Products Sales Representative for details authorized Siemens Building Technologies.

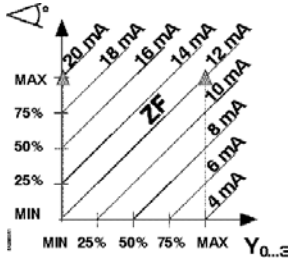

Figure 9. Split Ranging.

Cover Installation

Lift the two screws on the cover corners and slide the cover end into the groove at the gear end of the actuator (See Figure 10).

Press the cover into place and then press the screws inward and tighten (See Figure 11).

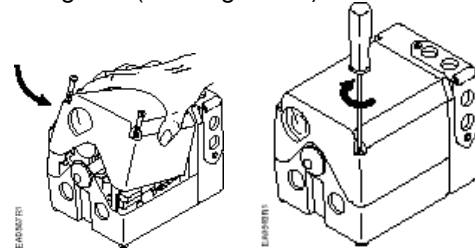

Figure 10.

Figure 11.

The installation is now complete.

Dimensions

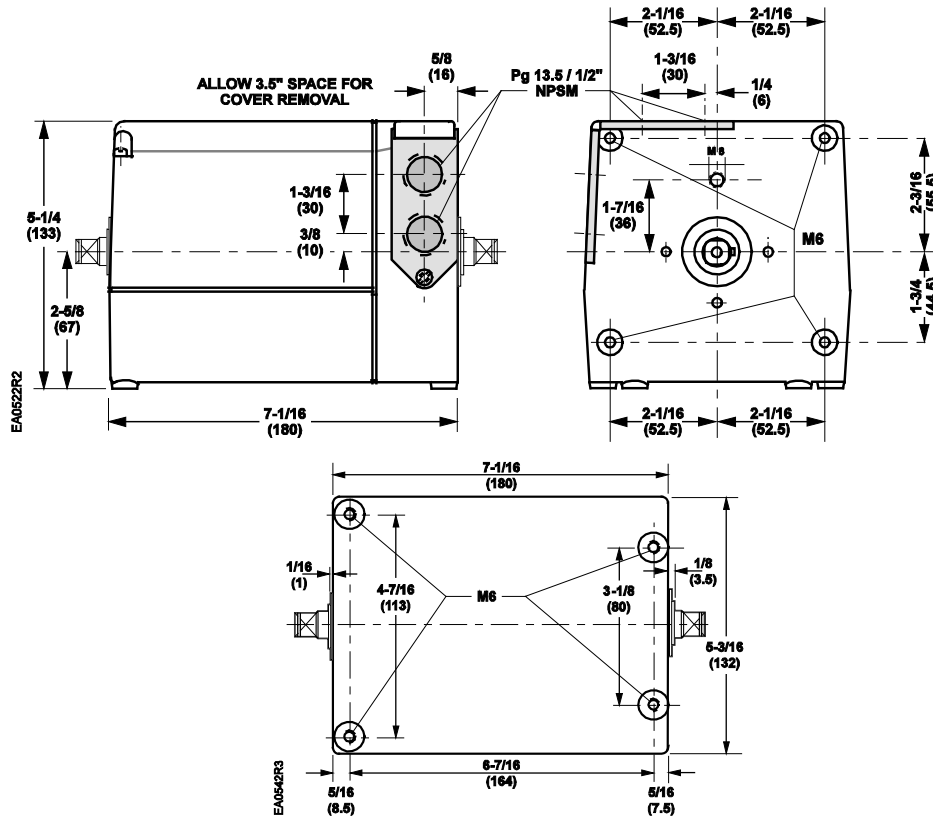

Figure 6. SQM5x.xxxRxx Dimensions in Inches (Millimeters).

Information in this publication is based on current specifications. The company reserves the right to make changes in specifications and models as design improvements are introduced. Product or company names mentioned herein may be the trademarks of their respective owners.
 © 2009 Siemens Industry, Inc.