

# Powers™ Controls

## RL 380 Check Valve



<b>Description</b>	The RL 380 Check Valve is a positive acting device that allows airflow in one direction only. An arrow indicates the direction of the flow. Each check valve is provided with an integral, one-way, elastomeric aperture that is resistant to oils and solvents, and a fine-mesh screen filter on the entering air side. Each end is provided with an integral barb fitting to facilitate direct connection to polyethylene or other resilient type tubing.	
<b>Specifications</b>	Air Capacity	30 scim at 1 psi PD (8.2ml/s at 6.9 kPa) 450 scim at 8 psi PD (123 ml/s at 55 kPa)
	Temperature Range	-20° to 300°F (7° to 149°C)
	Maximum Operating Pressure	30 psi (207 kPa)
	Piping Size	Integral barb for 1/4-inch OD tubing
	Dimensions	See Figure 5
<b>Product Number</b>	380-024 (Package of 10)	

**Operation**

The resilient material at the valve aperture is pre-formed. This facilitates the closing of the aperture whenever the pressure at the exit air side exceeds the entering pressure. Airflow in normal direction will not be affected except for a nominal pressure drop created by flow. One end of the cylindrical unit is marked with a ridge to identify the entering air side. See Figure 1.

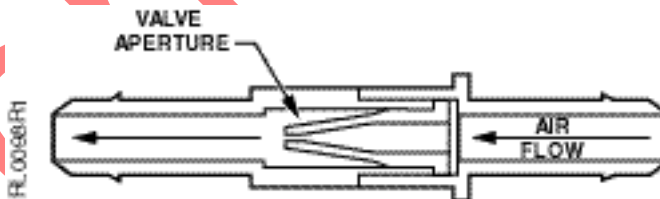

Figure 1. Operation.

### Application

The RL 380 Check Valve is primarily used in signal selection networks to obtain the highest and/or lowest pressure outputs (Figure 2). It also can be used as a fail-safe device when piped across a controller or switch to assure reduction of branch output pressure when the supply pressure is reduced (Figure 3). When piped in parallel with a fixed restrictor, it will allow full flow in one direction and restricted flow in the other direction (Figure 4).

### Highest Pressure Selection

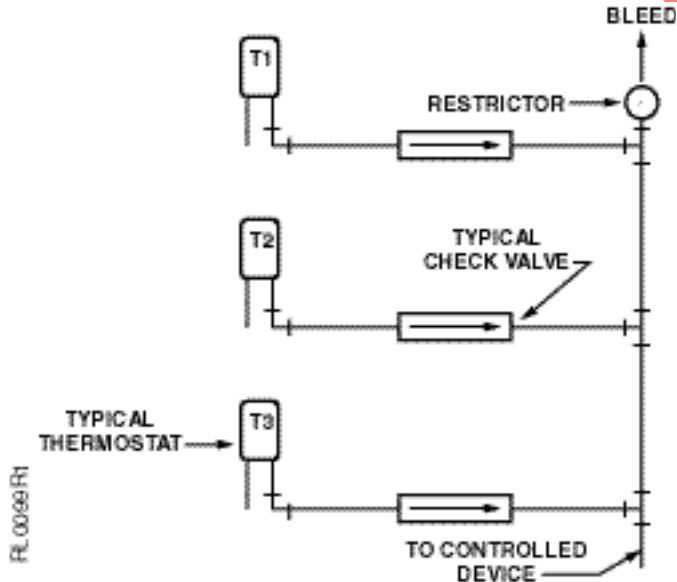

Figure 2. Highest Pressure Selection.

The output manifold will reflect the highest available pressure from any number of inputs.

### Fail-safe Relief

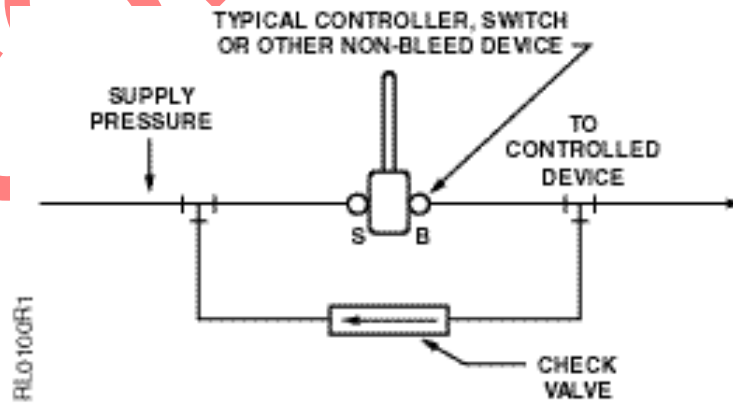

Figure 3. Fail-safe Relief.

Fail-safe relief assures reduction of controlled pressure whenever supply pressure is reduced.

## Flow Control

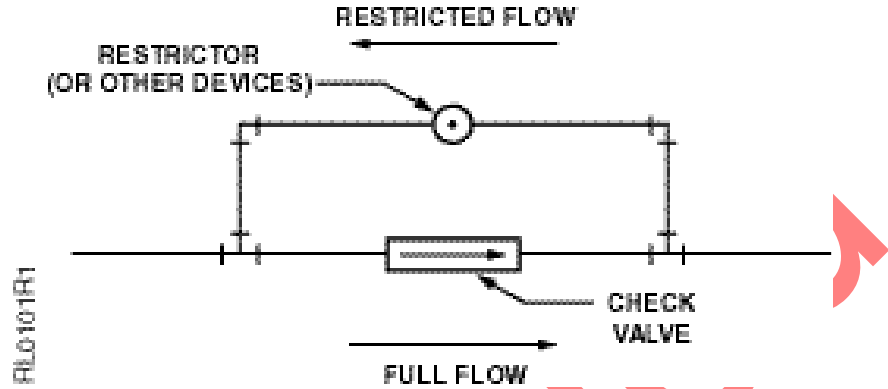

Figure 4. Flow Control.

Flow control will allow full flow in one direction only. Reverse flow is diverted to other devices piped in parallel to obtain the desired metering or control action.

## Installation

The small size and weight of this device allows direct support by the connecting tubing. A bracket or other support is not required and check valve may be mounted in any position.

**NOTE:** Do not disassemble or try to repair this device in the field. Replace any inoperative check valves with new units.

## Dimensions

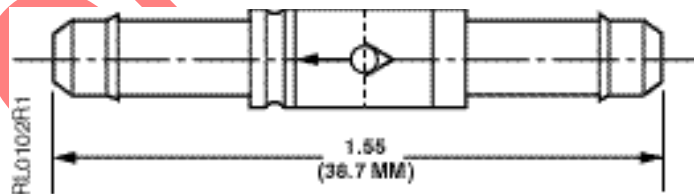

Figure 5. Dimensions.

Information in this publication is based on current specifications. The company reserves the right to make changes in specifications and models as design improvements are introduced. Powers is a registered trademark of Siemens Industry, Inc.. Product or company names mentioned herein may be the trademarks of their respective owners. © 2005 Siemens Industry, Inc.