

Desigo™

Compact Automation stations

PXC4.E16S-2/PXC4.E16-2



For the control of primary plants

- Compact automation station for HVAC and building control systems, freely programmable using graphical programming interface
- BACnet/IP communication (BTL certified)
- BACnet Secure Connect communication
- 2-port Ethernet switch for low-cost cabling
- 16 inputs/outputs: 12 universal inputs/outputs, 4 relay outputs
Extendable via I/O modules TXM...
- KNX PL-Link to connect sensors and operator units (including bus power)
- Integration of M-bus energy meters via RS485 level-converter
- Integration of Modbus data points via RTU and / or TCP
- WLAN interface for engineering and commissioning
- Operating voltage AC or DC 24 V
- Mounted on standard rails or on the wall
- Plug-in screw terminal blocks
- Building X integration

Functions

Optimized, flexible automation station for HVAC and building automation and control systems

- System functions (alarming, scheduling, trending, access protection with individually definable user profiles and categories)
- Integrates data points and/or subsystems via Modbus RTU and/or Modbus TCP
- Integration of wired M-bus meters via RS485 level-converter:
 - Offline and/or online engineering with ABT Site. No additional M-bus tool required
 - Primary and/or secondary device addressing
- The following functions are available with KNX PL-Link bus:
 - Communication with sensors and operator units
 - Plug-and-play connection of Siemens field devices with KNX PL-Link
- Engineering and commissioning with the ABT Site Tool using graphical function charts
- Freely programmable. All function blocks, available in libraries, can be graphically connected.
- BTL tested BACnet communication on IP (BACnet/IP or BACnet/SC), in compliance with the BACnet standard including B-BC profile (Rev. 1.20)
- IT security including HTTPS, IEC-62443 4-2 (Security Level 2*), and BACnet Secure Connect
- BACnet Secure Connect support as BACnet/SC node
- Generic operation via embedded web interface
- Direct cloud connectivity with Building X for remote access, data points time series, and data points commanding (changing state, writing setpoints, commanding outputs, etc.). BACnet alarms are forwarded to the cloud with automatic notifications via e-mail or SMS.
- 2-port Ethernet switch for low-cost cabling
- WLAN interface for engineering and commissioning
- Operating voltage AC 24 V or DC 24 V
- Direct connection of field devices
- DIN rail or screw mounting
- Plug-in screw terminal blocks

* For details about network and physical setup, refer to the Desigo Products Cybersecurity Guidelines (A6V14142297).

Type summary

PXC4.E16-2 variants ¹⁾	PXC4.E16S-2	PXC4.E16-2
Number of inputs and outputs (Onboard)	16	16
Number of universal inputs and outputs (UIO)	12	12
Number of relay outputs (DO)	4	4
Number of inputs and outputs (Onboard + TXM)	up to 50	up to 50
Number of integration data points (M-bus + Modbus TCP + Modbus RTU)	0	up to 40
Total number TXM-I/Os and integration DPs	50	90 ²⁾
Number of KNX PL-Link devices	0	up to 64 ²⁾
Number of configurable field level networks per RS485 (either for Modbus RTU or M-bus level converters with maximum of 250 meters each)	0	1
Number of M-bus meters wired via level converters (RS485) ³⁾	0	up to 250
Number of BACnet/SC nodes connected to PXC4.E16-2/PXC4.E16S-2 acting as hub	0 (node only)	0 (node only)

¹⁾ For details on engineering, see PXC4, PXC5 & PXC7 Planning overview (A6V13054435).

²⁾ KNX PL-Link data points do not count as integration points. For KNX PL-Link, only the limits on BACnet objects are considered.

³⁾ The limitation is given by the maximum number of integration data points and maximum number of BACnet objects.

Onboard inputs and outputs

UIO	Universal inputs and outputs support the following signal types: <ul style="list-style-type: none"> • Passive sensors LG-Ni 1000, 2x LG-Ni1000, Pt 1000 (375, 385), NTC 10k (Type II / Beta (0-50 °C) = 3892 K), NTC 100k • Resistance sensors 1000 Ohm, 2500 Ohm, 1000...1175 Ohm (for setpoint shift) • Voltage input analog DC 0...10 V • Current measurement analog DC 0...20 mA or 4...20 mA, (inputs U1, U2, U7, U8) • Binary potential-free contacts for signaling functions • Counter to 25 Hz (electronic switch to 100 Hz) • Analog outputs DC 0...10 V
DO	Relay outputs for binary controls, changeover contact (NO, NC, pulse)

Equipment combinations

TXM I/O Modules

Type ^{1,2)}	Description
TXM1.8D, TXM1.16D	Digital input module 8 or 16 I/O points
TXM1.8U, TXM1.8U-ML	Universal module with/without local operation and LCD
TXM1.8X, TXM1.8X-ML	Super universal module with/without local operation and LCD
TXM1.6R, TXM1.6R-M	Relay module with/without local operation
TXM1.4D3R	Digital input and relay module
TXS 1.12F4	Power supply module 24VDC 1200mA (28.8W)
TXS 1.EF4	Bus connection module
TXA 1.IBE	Island bus expansion module

1) Compatible with TXM1 Module series D and higher used with I/O bus communication mode "Event".

2) Automation Station can power TXM1 extensions modules.

KNX PL-Link devices

Description	Type	Data sheet
Wall-mounted temperature sensor	QMX3.P30	CM2N1602
Wall-mounted temperature and humidity sensor	QMX3.P40	
Wall-mounted temperature, humidity, and CO ₂ sensor	QMX3.P70	
Wall-mounted temperature sensor and room operator unit	QMX3.P34	
Wall-mounted temperature and humidity sensor and room operator unit	QMX3.P44	
Wall-mounted temperature, humidity, and CO ₂ sensor and room operator unit	QMX3.P74	
Wall-mounted temperature sensor	QMX6.P30	A6V16053428
Wall-mounted temperature and humidity sensor	QMX6.P40	
Wall-mounted temperature, humidity, and CO ₂ sensor	QMX6.P70	
Wall-mounted temperature sensor and room operator unit	QMX6.P34	
Wall-mounted temperature and humidity sensor and room operator unit	QMX6.P44	
Wall-mounted temperature, humidity, and CO ₂ sensor and room operator unit	QMX6.P74	
Wall-mounted temperature sensor and room operator unit	QMX2.P33	A6V10733768
Wall-mounted temperature and humidity sensor and room operator unit	QMX2.P43	

Description	Type	Data sheet
Flush-mounted room sensors base and front modules: <ul style="list-style-type: none"> • Base module for temperature and / or humidity measurement ¹⁾ • Base module for CO2 measurement ¹⁾ • Front module for base module without sensor • Front module for base module with temperature sensor • Front module for base module with humidity and temperature sensor • Front module for base module with humidity, temperature sensor, and CO2 indicator LED 	<ul style="list-style-type: none"> • AQR2570 • AQR2576 • AQR2530NNW • AQR2532NNW • AQR2535NNW • AQR2535NNWQ 	CE1N1411
Passive infrared presence detector	UP 258D12	A6V10489489
Presence detector WIDE with temperature sensor	UP 258D31	A6V11894530
Presence detector WIDE with temperature and humidity sensor	UP 258D41	
Presence detector WIDE with temperature, humidity, and CO2 sensor	UP 258D51	
Presence detector WIDE with temperature sensor and ultrasound	UP 258D61	

¹⁾ Physical data points on the base module AQR257.. for use in HVAC functions:

- 2 x Binary potential-free contacts (NO, NC)

- 1 x Passive sensor NTC10K (Type II / Beta (0-50 °C) = 3892 K)

For details see PXC4, PXC5 & PXC7 Planning overview (A6V13054435) and data sheets.

Desigo Control Point

Description	Type	Data sheet
BACnet touch panels with integrated data storage and web server functionality: 7.0 " 10.1 " 15.6 "	PXM30.E PXM40.E PXM50.E	A6V11664137
TCP/IP client touch panels with data storage in web server PXG3.Wx00-2: 7.0 " 10.1 " 15.6 "	PXM30-1 PXM40-1 PXM50-1	A6V11664139
BACnet/IP web server with standard functionality BACnet/IP web server with extended functionality	PXG3.W100-2 PXG3.W200-2	A6V12304192

Technical and mechanical design

The compact build allows for mounting the devices on a standard rail or a wall.

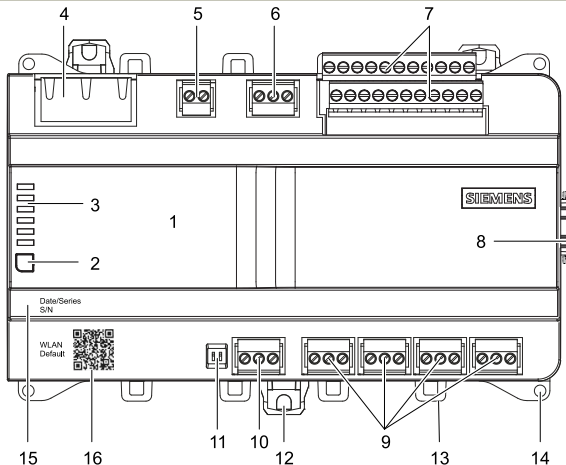

6	Plug-in terminal block with screw terminals Power supply
7	Plug-in terminal blocks with screw terminals Universal inputs/outputs, field device supply
8	Connector for I/O modules TXM
9	Plug-in terminal block with screw terminals Relay outputs
10	PXC4.E16-2: Plug-in terminal block with screw terminals COM, M-bus, Modbus RTU
11	PXC4.E16-2: DIP switch for bus termination and polarization COM
1	Plastic housing
2	Service button (identification in the network and WLAN on/off)
3	LEDs for communication and state
4	2-port Ethernet switch with 2 LEDs per port for display purposes
5	PXC4.E16-2: Plug-in terminal block with screw terminals KNX PL-Link
12	Slider for mounting on DIN rails
13	Eyelets for cable ties
14	Holes for wall mounting
15	Date / Series and Serial number
16	QR code for default WLAN access Description see Technical data

LED displays

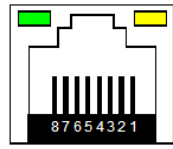
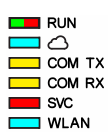
Activity	LED	Color	Activity	Function	
 	Ethernet 1/2	Green	Continuously ON Continuously OFF Flashing	Link active No connection Network traffic	
		Yellow	Continuously ON Continuously OFF	Link 100 Link 10 Mbps	
	RUN	Green	Continuously ON Continuously OFF Flashing	Device operational Device not operational Start-up or program halted	
		Red	Continuously OFF Continuously ON Rapid flashing	OK HW or SW fault Firmware or application missing/corrupted	
		Cloud icon	Blue	Steady ON Blinking Steady OFF	Cloud connection OK Cloud connection enabled but no connection available Cloud connection disabled
	COM TX (PXC4.E16-2)	Yellow	Flashing Continuously OFF	Communication No communication to subsystem	
	COM RX (PXC4.E16-2)	Yellow			
SVC	Red	Continuously OFF Flashing	OK Device is not configured		

Activity	LED	Color	Activity	Function
			Flashing per wink command	Identification of the device after receipt of wink command
	WLAN	Blue	Steady OFF Steady ON Flashing	WLAN inactive WLAN active and at least one WLAN client connected WLAN active and no WLAN client connected
 SVC	Service button		Press 0.2 ... 1 s	Identification in the network
			Press 1 ... 3 s	WLAN enable/disable WLAN disables automatically after 10 minutes if no client is connected
	As per description		Do the following to reset the device to factory state: <ol style="list-style-type: none"> 1. Power off the device. 2. Power on the device. 3. Wait until all LEDs light up and turn off again, then press the Service button. 4. Keep the Service button pressed until all LEDs light up, then release the button. All LEDs go off, the device restarts. 5. Wait until the device has fully started – unconfigured (green RUN LED and red SVC LED are flashing) 	

Product documentation



Topic	Title	Document ID
Datasheet	TX-I/O Product Range	149-476
Datasheet	Digital Input and Relay Module	CM2N8188
Installation Instruction	PXC4.x16-2	A6V13315074

Related documents such as the environmental declarations, declarations of conformity, etc., can be downloaded from the following Internet address:

www.siemens.com/bt/download

Notes

Safety

 CAUTION	
	<p>National safety regulations</p> <p>Failure to comply with national safety regulations may result in personal injury and property damage.</p> <ul style="list-style-type: none">• Observe national regulations and comply with the appropriate safety regulations.



Mounting position and ambient temperature



The devices can be snapped onto standard rails or screwed onto a flat surface.

Plug-in screw terminals connect power and interfaces.

Ambient temperature -5...50 °C (23...122 °F)	Ambient temperature -5...45 °C (23...113 °F)
<ul style="list-style-type: none">• Wall, horizontal<ul style="list-style-type: none">– From left to right– From right to left	<ul style="list-style-type: none">• Overhead• Wall, vertically<ul style="list-style-type: none">– From top to bottom– From bottom to top• On a horizontal surface

Installation

 WARNING	
	<p>No internal line protection for supply lines to external consumers</p> <p>Risk of fire and injury due to short circuits</p> <ul style="list-style-type: none">• Adapt the line diameters as per local regulations to the rated value of the installed fuse.

 WARNING	
	<p>The relay outputs may be connected to mains voltage</p> <p>Risk of electric shock! Incorrect installation of the device may lead to electric shock injuries when touching the device!</p> <ul style="list-style-type: none">• Install the device in a lockable cabinet or use terminal covers.• Do not install the device in locations where children are likely to be present.• Conductors with a cross-section of 0.5 mm² (AWG24) or greater shall comply with the requirements of IEC 60332-1-2 and IEC 60332-1-3 or IEC TS 60695-11-21.

Disposal



This symbol or any other national label indicates that the product, its packaging, and, where applicable, any batteries may not be disposed of as domestic waste. Delete all personal data and dispose of the item(s) at separate collection and recycling facilities in accordance with local and national regulations. For additional details, refer to [Siemens information on disposal](#).

Warranty

Technical data on specific applications are only valid together with Siemens products listed under "Equipment combinations". Siemens rejects any and all warranties in the event that third-party products are used.

Technical data

Housing

Color top / bottom	2003 Ti-Grey / 804 Black
Dimensions	per DIN 43880, see Dimensions
Weight without / with packaging	483 g / 553 g

Power supply

Operating Environment	
Ambient operating environment	Operate in a dry location protected from exposure to salt spray or other corrosive elements. Exposure to flammable or explosive vapors must be prevented.
Operating temperature	32°F to 122°F (0°C to 50°C)
Shipping and storage environment	-13°F to 158°F (-25°C to 70°C)
Relative Humidity	5% to 95% rh, non-condensing
Operating voltage (24 V~, ⚡, ⚡)	AC 24 V -15 / +20 % Class 2 Power Limited (US) 48...63 Hz
Operating voltage DC 24 V (24 V _{DC} , ⚡, ⚡)	DC 24 V -15 / +20 % Class 2 Power Limited (US)
Functional ground (US) Functional earth ⚡	The terminal for the functional ground must be connected on the installation side with the building grounding system (PE).
Screw terminals for wire cross sections up to	Max. 2.5 mm ² (14 AWG)
Internal fusing	4 A irreversible / non-replaceable

Operating Environment	
External supply line fusing (EU)	Non-renewable fuse max. 10 A slow-blow or circuit breaker max. 13 A Tripping characteristic B, C, D per EN 60898 or Power supply with current limitation of max. 10 A
Protection	Reverse connection protection for DC 24 V

Power consumption (for transformer planning)

Operating voltage	PXC4.E16S-2		PXC4.E16-2	
	AC 24 V	DC 24 V ¹⁾	AC 24 V	DC 24 V ¹⁾
Full load	78 VA / 3.25 A	66 W / 2.75 A	82 VA / 3.4 A	68 W / 2.83 A
Base load PXC4.E16S-2: without loading by I/O modules TXM and field devices PXC4.E16-2: without loading by I/O modules TXM, KNX PL-Link, and field devices	10 VA / 0.4 A	6 W / 0.25 A	10 VA / 0.4 A	6 W / 0.25 A
Field device supply V+ (DC 24 V, 100 mA) (terminals 8 and 19)	5 VA / 0.2 A	3 W / 0.13 A	5 VA / 0.2 A	3 W / 0.13 A
Field device supply V≈ (terminals 18 and 29)	48 VA / 2 A	48 W / 2 A	48 VA / 2 A	48 W / 2 A
I/O modules TXM supply	15 VA / 0.6 A	8.5 W / 0.35 A	15 VA / 0.6 A	8.5 W / 0.35 A
KNX PL-Link supply			4 VA / 0.17 A	2.2 W / 0.09 A

¹⁾ For Energy Management (UL 916) only.

Function data

Hardware information	PXC4.E16-2, PXC4.E16S-2
Processor	Texas Instruments AM335x, 600 MHz
Storage	512 MByte RAM 512 MByte Flash

Data backup in the event of power failure

Energy reserve (supercap) to support real-time clock (7 days).

Data available if stored to flash memory. Occurs every 5 minutes.

The interval of 5 minutes is only valid for change log but not for trending.

In case of a power failure, trend log data can be lost up to 30 minutes.

Interfaces

Ethernet interface	
Plug	2 x RJ45, shielded
Interface type	10Base-T / 100Base-TX, IEEE 802.3 compatible
Bit rate	10/100 Mbps, autosensing
Protocol	BACnet/IP on UDP/IP, BACnet/SC on TCP/IP, and HTTPS on TCP/IP
Cabling (in-house cabling only), cable type	10 Mbps: Min. CAT3, shielded cable is recommended 100 Mbps: Min. CAT5, shielded cable is recommended
Cable length	Max. 100 m (330 ft)

WLAN interface	
Interface type	Wireless access point
Supported standards	IEEE 802.11b/g/n
Frequency band	2.4...2.462 GHz
WLAN channels	1...11
Maximum radio-frequency power	16.4 dBm
Distance (unobstructed field)	Min. 5 m (16 ft)
Device pairing	Activation / deactivation with service button Automatic switch off after 10 minutes if no WLAN-client is connected. Optionally, for cyber security reasons, the WLAN can be permanently disabled via configuration.
<p>Default SSID and WLAN password: Scan the QR code. It will display something like WIFI:S:PXC4.E16-2_0000550;T:WPA;P:1400052738;; Then SSID = PXC4.E16-2_0000550 and password = 1400052738 Determine manually: Use the information from the Date/Series/SN block It will display something like: Date/Series: 20190423A0000550 S/N: 1400052738 SSID = <ASN>_<Running number after the series letter> and password = <S/N></p>	

M-bus interface on COM interface (RS485)	
Interface type	EIA-485, electrically isolated
Baud rate	300, 600, 1200, 2400, 4800, 9600, 19200, 38400. The maximum baud rate is depending on the configuration of M-bus S-devices (subordinate devices) and M-bus repeater.
Internal bus termination	120 Ohm, switchable with DIP switch
Internal bus polarization	270 Ohm pull-up/pull-down resistances, switchable with DIP switch
Cabling (in-house cabling only)	3-wire cable, shielded cable recommended (shield must be connected to building earth in the mounting panel)

M-bus interface on COM interface (RS485)	
Cable length	Max. 1000 m (3300 ft)
Protection	Short-circuit proof Protection against faulty wiring with AC 24 V and DC 24 V
M-bus level converter including power supply (required)	Configuration examples (simple M-bus loads à 1.5 mA): <ul style="list-style-type: none"> • Up to 2 M-bus devices: STV Electronic, MPW-2 ¹ • Up to 6 M-bus devices: STV Electronic, MPW-6 ¹ • Up to 60 M-bus devices: Relay GmbH, PW60 ¹

¹ For STV Electronic level converters, refer to <https://www.stv-electronic.de/>. For Relay GmbH level converters, refer to <https://www.relay.de/>.

The use of these products is a recommendation only. Siemens cannot guarantee functionality nor take over any warranty for third-party products. This information is subject to change without notice.

KNX PL-Link interface	
Type	KNX TP1 PL-Link, galvanic isolation Baud rate: 9.6 kbps
Cabling (in-house cabling only)	2-wire cable, 0.75 mm ² / AWG20 or 1 mm ² / AWG18
Cable length	With internal supply: Max. 80 m (262 ft) With external supply: Max. 1000 m (3300 ft)
Internal bus power	Max. 50 mA When using external bus power for KNX PL-Link, switch off the internal bus power via the ABT Site Tool.

I/O modules TXM bus interface	
Nominal voltage	DC 24 V
Supply current for I/O modules TXM	Max. 300 mA
Connectable in parallel with DC 24 V power supply module TXS1.12F4	For details, see: TX-I/O- engineering and installation, CM110562
Protection	Short-circuit proof
TXM I/O module plug: Protection against faulty wiring	No protection, use cover.

Field device supply (I/O module TXM)	
AC 24 V output current (terminal V~ on the TXM module)	Max. 2 A, short-circuit proof ¹⁾ If PXC4.E16-2 is powered by DC voltage, the field device supply on terminal V~ of the TXM modules is also DC voltage.

¹⁾ Sum of onboard V~ and TXM module V~ current is max. 2 A.

Field device supply (Onboard)	
AC 24 V output current (terminal V≈)	Max. 2 A, short-circuit proof ¹⁾ If PXC4.E16-2 is powered by DC voltage, the field device supply on terminal V≈ is also DC voltage.
DC 24 V output current (terminal V+)	Max. 100 mA, short-circuit proof, protected against incorrect wiring with AC 24 V

¹⁾ Sum of onboard V~ and TXM module V~ current is max. 2 A.

Screw terminals, plug-in	
Cu-wire or Cu-strand with wire end sleeve	1 x 0.6 mm Ø to 2.5 mm ² (22 to 14 AWG) or 2 x 0.6 mm Ø to 1.0 mm ² (22 to 18 AWG)
Cu-strand without wire end sleeve	1 x 0.6 mm Ø to 2.5 mm ² (22 to 14 AWG) or 2 x 0.6 mm Ø to 1.5 mm ² (22 to 16 AWG)
Stripping length	6...7.5 mm (0.24...0.29 in)
Screwdriver	Slot screws, screwdriver size 1 with shaft Ø = 3 mm
Max. tightening torque	0.6 Nm (0.44 lb ft)

On PXC4.E16-2

Modbus RTU interface	
Interface type	EIA-485, electrically isolated
Baud rate	300, 600, 1200, 2400, 4800, 9600, 19200, 38400, 57600, 76800, 115200 (depending on the configuration)
Internal bus termination	120 Ohm, switchable with DIP switch
Internal bus polarization	270 Ohm pull-up/pull-down resistances, switchable with DIP switch
Cabling (in-house cabling only)	3-wire cable, shielded cable recommended (shield must be connected to building earth in the mounting panel)
Cable length	Max. 1000 m (3300 ft)
Protection	Short-circuit proof Protection against faulty wiring with AC 24 V and DC 24 V

Inputs

12 universal inputs / outputs U1...U12 with the following input functions (16-bit AD converter):

Temperature measurement, analog		
Type	Range (over range)	Resolution
AI NTC10K (Type II / Beta (0-50 °C) = 3892 K)	-40...115 °C (-52.5...155 °C) -48...239 °F (-62.5...311 °F)	10 mK (25 °C) 0.018 °F
AI NTC100K	-40...125 °C (-52.5...155 °C) -48...257 °F (-62.5...311 °F)	
AI PT1K 385 (EU) ¹⁾	-50...600 °C (-52.5...610 °C) -58...1112 °F (-62.5...1130 °F)	20 mK 0.036 °F

Temperature measurement, analog		
Type	Range (over range)	Resolution
AI PT1K 375 (NA) ¹⁾	-50...180 °C (-52.5...185 °C) -58...356 °F (-62.5...365 °F)	10 mK 0.018 °F
AI (LG-)Ni1000 ¹⁾		
AI 2x (LG-)Ni1000 ¹⁾		

¹⁾ A fixed value of 1 Ω is calibrated to correct line resistance.

Resistance sensor, analog		
Type	Range (over range)	Resolution
AI 1000 Ohm ¹⁾	0...1000 Ω (0...1050 Ω)	0.1 Ω
AI 2500 Ohm ¹⁾	0...2500 Ω (0...2650 Ω)	0.1 Ω
AI Pt1000 ¹⁾	0...2500 Ω (0...2650 Ω)	0.1 Ω
AI 1000-1175 Ohm ¹⁾ for setpoint shift	1000...1175 Ω (900...1295 Ω)	0.1 Ω

¹⁾ A fixed value of 1 Ω is calibrated to correct line resistance.

Voltage measurement, analog		
Type	Range (over range)	Resolution
AI 0-10 V	0...10 V (-1.5...11.5 V)	1 mV
AI 0-10 V standard	0...100% (-10...110%)	0.01%
Open connection: Negative voltage -1.5 V (line failure detection)		

Current measurement, analog (only inputs U1, U2, U7, U8)			
Type	Range (over range)	Resolution	Load resistance
AI 4-20 mA	4...20 mA (1.6...22.4 mA)	1 μA	440 / 490 Ω
AI 0-20 mA	0...20 mA (-3...23 mA)	1 μA	440 / 490 Ω

Digital input			
Contact query voltage		21.5...25 V	
Contact query current		1 mA; 6 mA initial current	
Contact resistance for closed contacts		Max. 200 Ω	
Contact resistance for open contacts		Min. 50 kΩ	
Counter memory (counter inputs		0 ... 4.3 x 10 ⁹ (32-bit counter)	
	Min. closing/operating time [ms] including bounces	Of which Max. bounce time [ms]	Max. counter frequency (symmetrical)
BI NO / BI NC	60	20	
BI Pulse NO	30	10	
CI Mech (25 Hz)	20	10	25 Hz
CI EI (100 Hz)	5	0	100 Hz

Outputs

12 universal inputs / outputs U1...U12 with the following output functions (10-bit DA converter):

Voltage output, analog			
Type	Range (over range)	Resolution	Output current
AO 0-10 V	0...10 V (-0.05...10.6 V)	1 mV	Max. 1 mA
AO 0-10 V standard	0...100% 0% = 0 V, 100% = 10 V (-0.05...10.6 V)	0.01 %	Max. 1 mA

Relay output (outputs DO1...DO4) 	
External supply line fusing Non-renewable fuse Circuit breakers	Max. 10 A, slow Max. 13 A, characteristic B, C, D as per EN 60898
Switching voltage AC/DC	Max. AC 250 V / DC 30 V Min. AC/DC 12 V
Current load AC	NO contact: Max. 4 A resistive, 3 A inductive (cos phi 0.6) NC contact: max. 2 A resistive, 1.5 A inductive (cos phi 0.6) Min. 1 mA at AC 250 V Min. 10 mA at AC 12 V
Current on make AC	NO contact: Max. 10 A (1 s) NC contact: Max. 3 A (1 s)
Current load DC	NO contact: Max. 3 A resistive at DC 30 V NC contact: Max. 1 A resistive at DC 30 V Min. 10 mA resistive at DC 12 V
Response / release time	7 ms / 3 ms typical
Contact life at AC 250 V (reference values) At 0.3 A resistive NO contact at 3 A resistive NC contact at 2 A resistive Reduction factor for inductive load (cos phi = 0.6)	5 x 10 ⁵ switching cycles 1 x 10 ⁵ switching cycles 1 x 10 ⁵ switching cycles 0.6
Insulating strength between relay contacts and system electronics (reinforced insulation).	AC 3750 V, as per EN 60730-1

CAUTION



No overvoltage protection is used when switching inductive loads

Risk of heavy electromagnetic disturbances and lower contact life when no overvoltage protection is used when switching inductive loads.

- When switching inductive loads (e.g. contactors or electric motors) it is strongly recommended to use suitable overvoltage protection devices to avoid heavy electromagnetic disturbances and to ensure the specified contact life.

Conformity

Ambient conditions and protection classification	
Classification as per EN 60730 Automatic action Control function Pollution degree Overvoltage category	Type 1 Class A 2 III
Protection against electric shock	Suitable for use in protection class I or II systems
Protection degree of housing to EN 60529 Front parts in DIN cut-out Terminal part	IP30 IP20
Climatic ambient conditions <ul style="list-style-type: none"> Storage / Transport (packaged for transport) as per IEC EN 60721-3-1 / IEC EN 60721-3-2 Operation as per IEC/EN 60721-3-3 	<ul style="list-style-type: none"> Class 1K22 / 2K12 Temperature -25...70 °C (-13...158 °F) Air humidity 5...95 % (non-condensing) Class 3K23 Operation in enclosed dry locations, having no temperature or humidity control Temperature -5...50 °C (23...122 °F) <i>(for details see chapter Mounting)</i> Air humidity 5...95 % (non-condensing)
Mechanical ambient conditions <ul style="list-style-type: none"> Transport per IEC/EN 60721-3-2 Operation as per IEC/EN 60721-3-3 	<ul style="list-style-type: none"> Class 2M4 Class 3M11

Standards, directives, and approvals	
Product standard	IEC/EN 60730-1
Product family standards	IEC/EN 63044-x
Electromagnetic compatibility (EMC)	For residential, commercial, and industrial environments
EU conformity (CE)	See CE declaration ¹⁾
EAC conformity	Eurasian compliance
RCM conformity	See RCM declaration ¹⁾
UL/cUL certification (US / Canada)	UL916, http://ul.com/database ^{4a)} UL94, housing material meets classification V-0 ²⁾ UL 864 - Conforms to UL 864 9th and 10th Edition. ^{4b)} CAN-ULC-527-2024, 5th edition ^{4b)}
CSA certification	C22.2 No. 205, 3rd Edition, http://csagroup.org/services-industries/product-listing ^{4a)}
FCC	CFR 47 Part 15C
BACnet	Profile: B-BC Revision: 1.20 Detailed information on BACnet certificates, BTL listings, and PICS can be found on the BACnet website (filtered for Siemens products)
AMEV profile (BACnet 2017 / BACTwin 2025)	AS-D (includes profiles AS-A, AS-B, and AS-C) ³⁾

Standards, directives, and approvals	
KBOB profile (BACnet 2017)	AS-CH
Environmental compatibility ¹⁾	The product environmental declaration ¹⁾ contains data on environmentally compatible product design and assessments (RoHS compliance, materials composition, packaging, environmental benefit, disposal).
OSHPD seismic certification	Product meets OSHPD Special Seismic Certification Preapproval under California Building Code 2022 (CBC 2022) ^{4c)}

¹⁾ Documents can be downloaded at www.siemens.com/bt/download.

²⁾ Material level

³⁾ AS-C and AS-D pending

⁴⁾ When installed within the following enclosures: a) NEMA Type 1 minimum; b) Siemens PXA-ENC19, or PXA-ENC34; c) Siemens PXA-ENC18, PXA-ENC19, or PXA-ENC34.

European Union conformity

Contact for regulatory topics: (EU) Siemens AG, Berliner Ring 23, DE-76437 Rastatt

FCC Statement

This equipment has been tested and found to comply with the limits for a Class B digital device, pursuant to part 15 of the FCC Rules. These limits are designed to provide reasonable protection against harmful interference in a residential installation. This equipment generates, uses and can radiate radio frequency energy and, if not installed and used in accordance with the instructions, may cause harmful interference to radio communications. However, there is no guarantee that interference will not occur in a particular installation. If this equipment does cause harmful interference to radio or television reception, which can be determined by turning the equipment off and on, the user is encouraged to try to correct the interference by one or more of the following measures:

- Reorient or relocate the receiving antenna.
- Increase the separation between the equipment and receiver.
- Connect the equipment into an outlet on a circuit different from that to which the receiver is connected.
- Consult the dealer or an experienced radio/TV technician for help.

This device complies with Part 15 of the FCC rules. Operation is subject to the following two conditions:

1. This device may not cause harmful interference, and
2. This device must accept any interference received, including interference that may cause undesired operation

FCC Caution: Changes or modifications not expressly approved by Siemens Switzerland Ltd. could void user authority to operate the equipment. United States representative

<https://new.siemens.com/us/en/products/buildingtechnologies/home.html>

Industry Canada statement

This device complies with ISSED's license-exempt RSSs. Operation is subject to the following two conditions:

1. This device may not cause interference, and
2. This device must accept any interference received, including interference that may cause undesired operation.

Radiofrequency radiation exposure statement

This equipment complies with FCC and IC radiation exposure limits set forth for an uncontrolled environment. This equipment should be installed and operated with a minimum distance of 20 cm between the radiator and your body.

This transmitter must not be co-located or operated in conjunction with any other antenna or transmitter.

Connection terminals

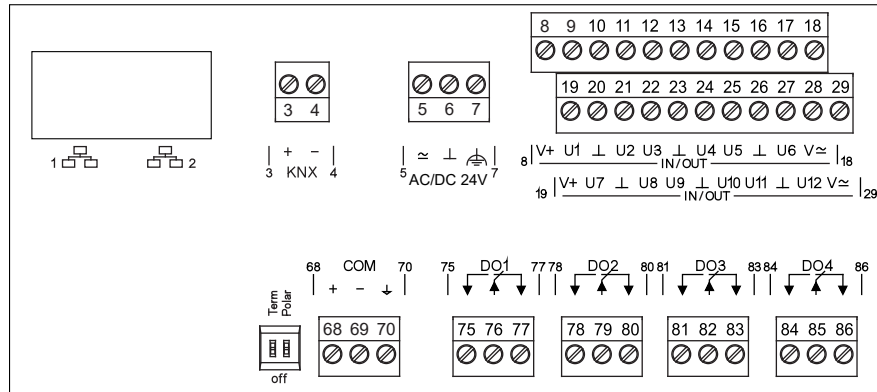

Terminal	Symbol	Description	Module	Channel
1, 2		2 x RJ45 interface for Ethernet with switch		
3, 4	KNX	PXC4.E16-2: KNX PL-Link		
5, 6	≈, ⊥	Operating voltage AC 24 V or DC 24 V		
7		Functional ground (must be connected on the installation side with the building grounding system (PE)).		
9 to 17 20 to 28	Ux	Universal inputs / outputs 1...12	61	1...12
	⊥	Measuring ground for Ux		
8, 19	V+	DC 24 V power for field devices 2.4 W / <100 mA		
18, 29	V≈	AC 24 V power for field devices 48 VA / 2 A (If PXC4.E16-2 is powered by DC voltage, then the field device supply on terminal V≈ is DC voltage, too)		
68, 69, 70	COM	PXC4.E16-2: Interface EIA-485 (M-bus, Modbus RTU)		
Term	on, off	PXC4.E16-2: Switch for bus termination		
Polar	on, off	Switch for polarization		
75 to 86	DOx	Relay outputs 1...4	11	1...4

Wiring lines for field devices

Wiring length max. 300 m (1,000 ft), CU wire or CU strand.

Cross-section depending on the signal

30 m (100 ft) applies for signal types AI NTC10K and AI NTC100K
or 300 m (984 ft) with shielding

Examples of connection diagrams for universal inputs/outputs

Digital inputs

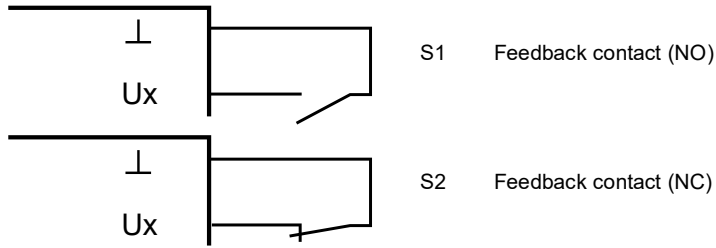

Count inputs:

Counter inputs, that count faster than 1 Hz and are laid with more than 10 meters using analog inputs in the same cable duct, must be shielded.

Analog inputs

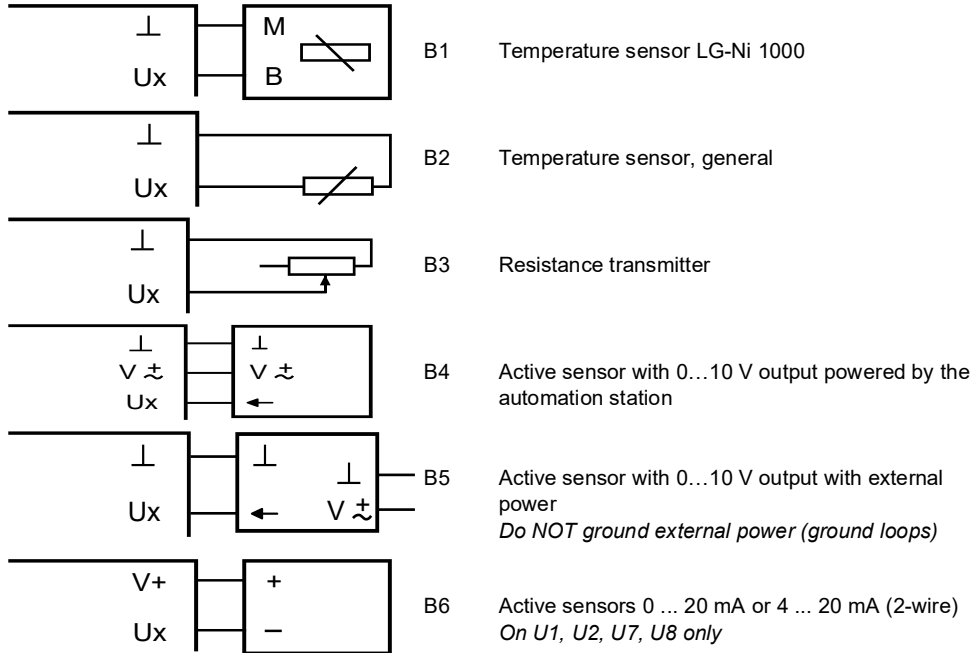

Analog outputs

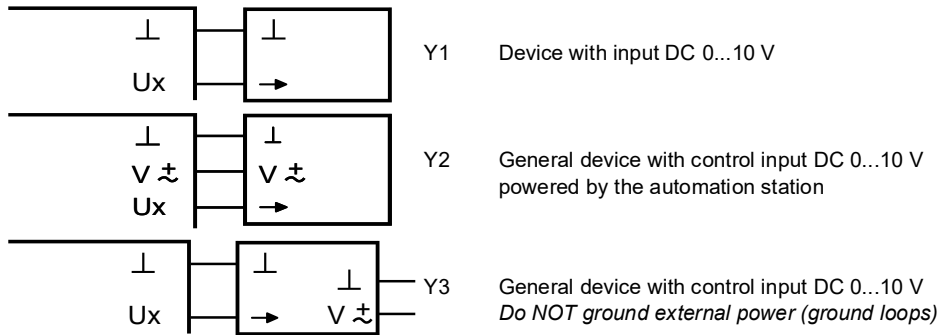

Dimensions

All dimensions in mm and inches.

PXC4.E16-2

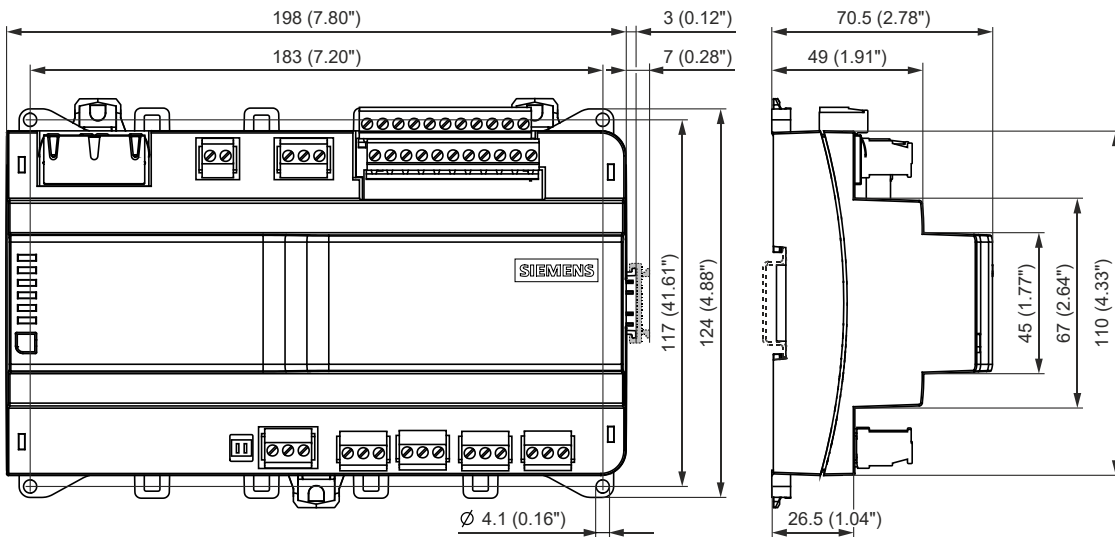

PXC4.E16-2 with TXM module

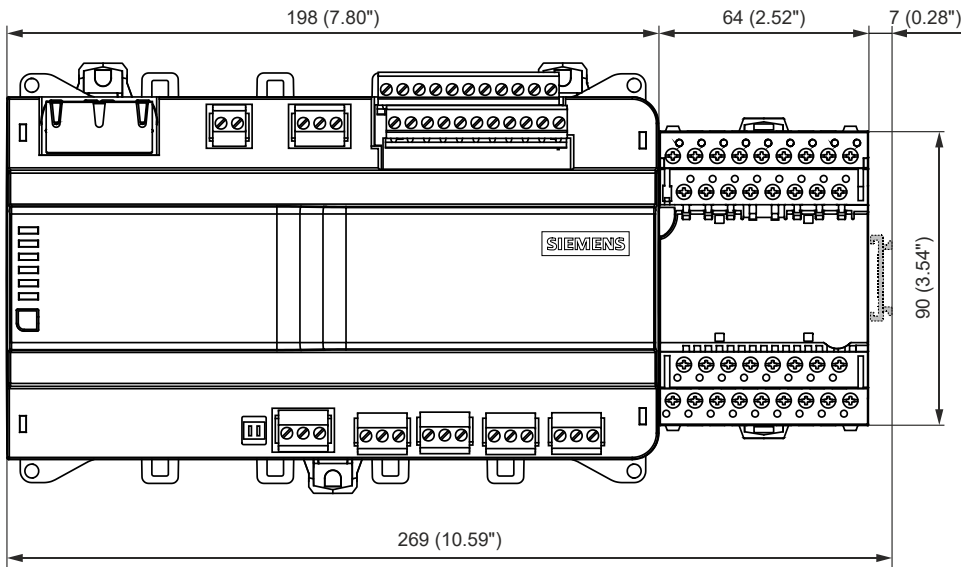

Issued by
Siemens Industry, Inc.
Smart Infrastructure
1000 Deerfield Pkwy
Buffalo Grove IL 60089
+1 847-215-1000

© Siemens 2021
Technical specifications and availability subject to change without notice