

## Installation Instructions

### Models HMS-SZ / HMS-DZ

### Models HMS-SE / HMS-DE (Spanish versions)

### Models HMS-SP / HMS-DP (Portuguese versions)

Single/Dual Action Manual Pull Station

#### INTRODUCTION

The Model HMS-SZ and HMS-DZ Manual Stations, and their Spanish and Portuguese versions, from Siemens Industry, Inc., are field installed addressable devices containing advanced control panel communication technology. This technology, which provides two-direction communication with the control panel, produces an Intelligent Initiating Device. The HMS-SZ/-SE/-SP are single action; the HMS-DZ/-DE/-DP are double action.

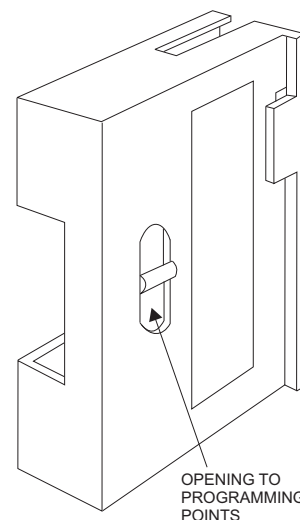

Figure 1  
MS Cover

#### PROGRAMMING INSTRUCTIONS

Refer to Figure 1 to locate the opening on the MS cover that allows access to the programming holes which are on the HMS printed circuit board.

To connect the HMS to the DPU Programmer/Tester, insert the plug from the DPU cable provided with the Programmer/Tester into the opening on the HMS as shown in Figure 2. Because HMS devices are polarity insensitive, the programming plug can be inserted into the programming holes in either direction.



To prevent potential damage to the DPU **DO NOT** connect an HMS to the DPU until at least one wire is removed from terminals 1 or 2 of the HMS.

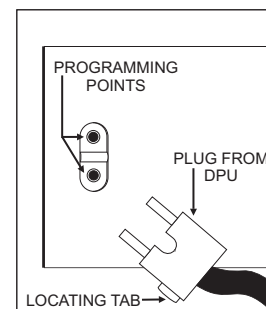

Figure 2  
Connecting the DPU Plug

Follow the instructions in the DPU Manual (P/N 315-033260) to program the HMS to the desired address. Record the device address on the label located on the HMS front panel. The HMS can now be installed and wired to the system.

#### OPERATION

The HMS-SZ and HMS-DZ manual stations, as well as their Spanish and Portuguese versions, operate with the FireFinder-XLS or FS-250 Control Panels via the DLC or FS-DLC Device Loop Card.

All HMS manual station housings have a pull down lever that locks in position after releasing a spring loaded switch. (See Figure 4.) To indicate the manual station is activated, the pull down lever remains down and locked until the station is physically reset.

The HMS-DZ/-DE/-DP have an additional lever labeled *PUSH IN/EMPUJE/EMPURRE* which must be operated first.

All models are reset by opening the hinged housing cover with an Allen key and then closing and locking the cover.

## WIRING

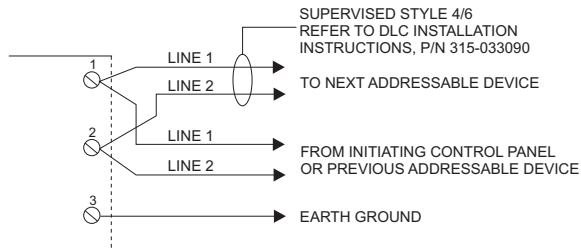

Figure 3  
Wiring Information

## NOTES:

1. Recommended wire sizes:  
18 AWG minimum, 14 AWG maximum
2. Wire larger than 14 AWG can damage the connector.
3. **When using shielded cable without metal raceway or with nonmetallic raceway**, the shields should be terminated at the device ground terminal. If the device box is already grounded by another means, such as being mounted to a grounded structure, the wire shields should be continuous and must be grounded solely at the point of origin; for example, at the control panel.
4. **When using shielded cable with metal raceway**, the wiring shields shall be continuous and grounded solely at the point of origin. The device ground terminal shall be connected to the grounded device box.
5. **When using metal raceway without shielded cable**, connect the device ground terminal to the grounded device box.
6. Metal raceway should be thoroughly grounded throughout the system.
7. In supervisory: All HMS manual stations draw 1mA.
8. All HMS manual stations are polarity insensitive devices. Line 1 and Line 2 can be either line of the DLC or FS-DLC loop.

## INSTALLATION

Distribute the manual station boxes throughout the protected area so that they are unobstructed, readily accessible, and located in the normal exit path. Place the manual station according to the regulations of the authorities having jurisdiction.

### Surface Mounting

Mount the backplate to a Model SB-5R Backbox as shown in Figure 4.

### Flush Mounting

Mount the backplate to a user supplied single gang switchbox.



Do not overtighten the screws. Overtightening may distort the backplate.

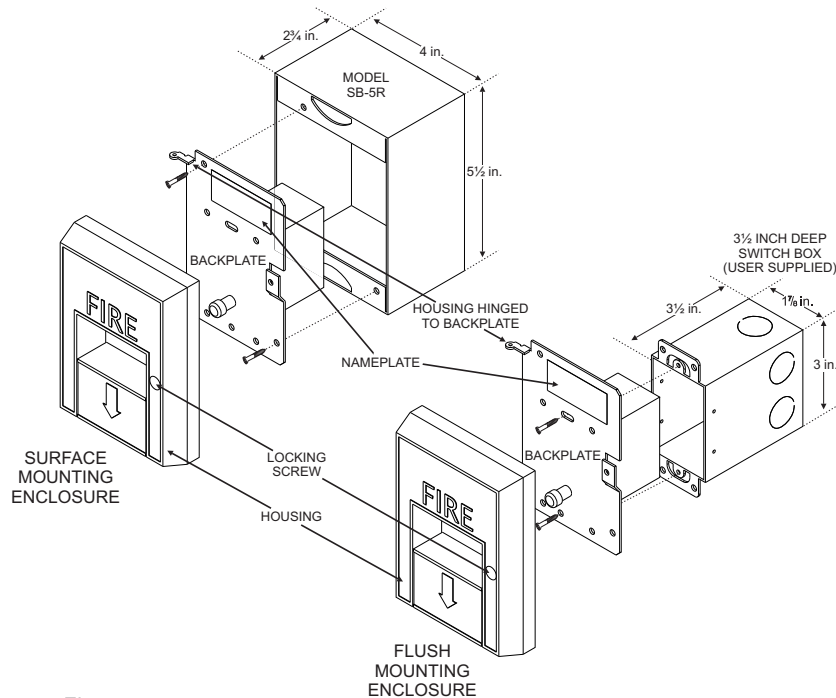

Figure 4  
Mounting The HMS

## ELECTRICAL RATINGS

DLC / FS-DLC Loop	
Max. Current	1mA

## **Cyber security disclaimer**

Siemens products and solutions provide security functions to ensure the secure operation of building comfort, fire safety, security management and physical security systems. The security functions on these products and solutions are important components of a comprehensive security concept.

It is, however, necessary to implement and maintain a comprehensive, state-of-the-art security concept that is customized to individual security needs. Such a security concept may result in additional site-specific preventive action to ensure that the building comfort, fire safety, security management or physical security system for your site are operated in a secure manner. These measures may include, but are not limited to, separating networks, physically protecting system components, user awareness programs, defense in depth, etc.

For additional information on building technology security and our offerings, contact your Siemens sales or project department. We strongly recommend customers to follow our security advisories, which provide information on the latest security threats, patches and other mitigation measures.

<http://www.siemens.com/cert/en/cert-security-advisories.htm>

THIS PAGE HAS BEEN LEFT INTENTIONALLY BLANK.