

OP722-CN Smoke detector Product manual

Overview

OP722-CN point-type photoelectric smoke detector uses optical sensors and works according to the principle of forward and backward bi-directional scattering. Through an extraordinarily sensitive response to smoke aerosols produced by fire, the detector significantly improves detection sensitivity to open flames or smoldering smoke/mist, enabling early fire detection.

Features

- Compliance with EN 54-7 and EN 54-17
- Particularly suitable for early detection of open flames and smoldering smoke/mist
- Strong resistance to environmental interference factors such as dust, fibers, insects, humidity, extreme temperatures, electro-magnetic interference, corrosive vapors, vibration, and non-fire smoke
- Integrated line separator
- Communication with the control panel via C-NET
- Automatic compensation to reduce the effect of dust on the detection sensitivity. When the detector is severely contaminated and the compensation does not work, a fault is reported to the control panel, and the contamination alarm indicator is illuminated.
- Adoption of environmentally friendly materials and production processes that fully comply with RoHS requirements

Application

The OP722-CN smoke fire detector responds quickly to smoke/mist produced by smoldering fires and is suitable for early fire detection in interior spaces of buildings.

The OP722-CN smoke detector has two parameter settings:

Standard (1/Default).

For standard applications, such as in corridors, bedrooms, offices, and living rooms.

Sensitive (2).

For application in environments with few misleading sources of false alarms, such as cigarette, exhaust fumes, and steam.

The table below shows the parameter properties of the OP720-CN smoke detector:

No.	Designation	Sensitivity [%/m]
1	Standard	8.8
2	Sensitive	4.4

LED indicator

The detector is equipped with LED indicators. The table below lists the operating modes of the detector as indicated by the status of the indicators.

Detector status	LED status
Normal	Off
Locate	Red light flashes every 1 second
Fire alarm	Red light steady on
Contaminated	Yellow light steady on

Installation

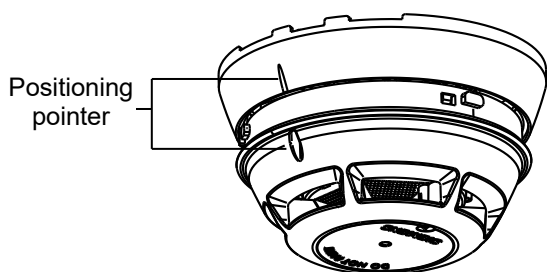

Fig. 1

- Internal Alarm Indicator (AI) centered, no alignment required

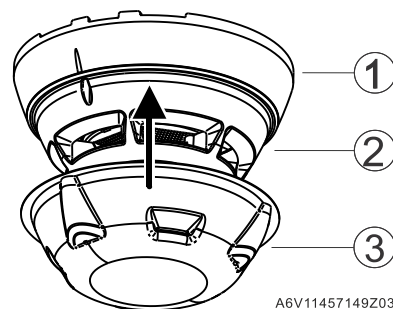

Fig. 2

1 - Detector base. 2 - Detector
3 - Detector dust cap

- Easy, time-saving and high-quality mounting (Fig. 1)**
 Before the detector can be installed, the detector base must be installed. After installing the detector base, simply insert the detector into the base and turn it clockwise, until the positioning pointer of the detector aligns with the positioning pointer of the base. To remove, simply rotate counterclockwise to detach.
- Detector dust cap (Fig. 2)**
 A detector dust cap is provided as part of the scope of supply for each detector. During construction phase, the detector dust cap protects the detector from dust and dirt.



The dust cap must be removed when all construction is fully completed!

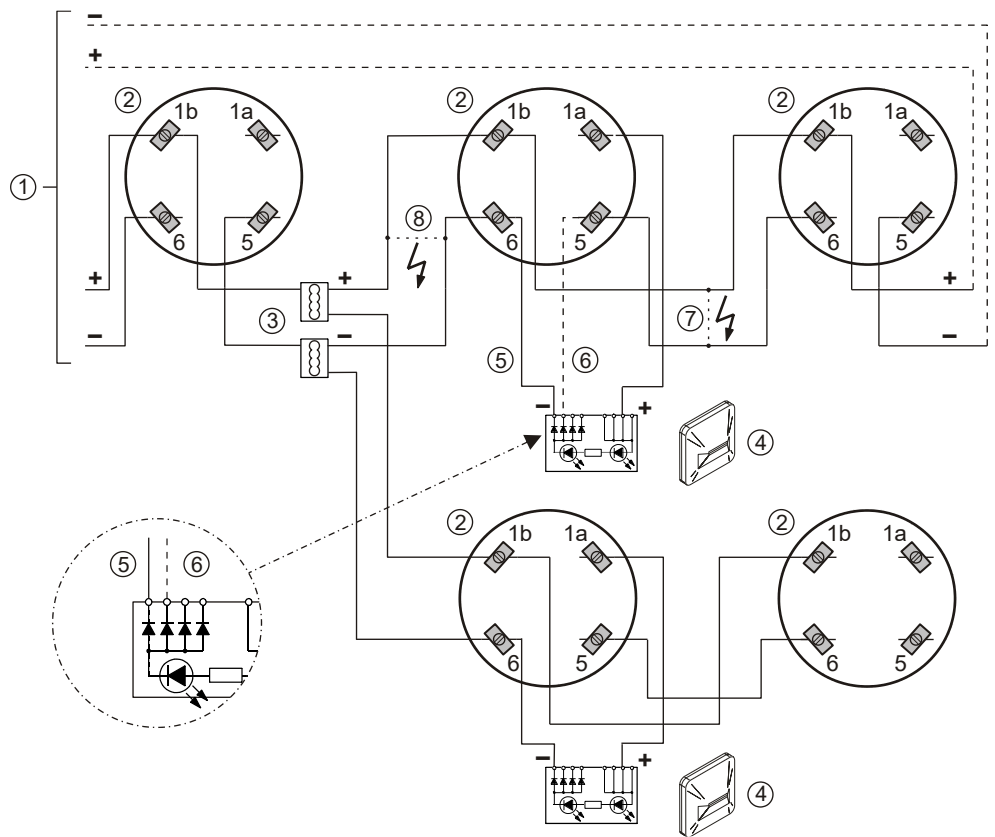

Legend

1	Control panel	5	Cable –E_AI6
2	Detector base DB721-CN	6	Cable –E_AI5 (optional)
3	Connection terminal DBZ1190-XX	7	Short-circuit (fault)
4	External alarm indicator	8	Short-circuit (fault)

Comments

- If a shielded cable is used for connecting the external alarm indicator, its shield must be connected to the shield for the detector bus.
- The alarm indicator connected will continue to function correctly in the event of a short circuit occurring at position 7 on the connection diagram. The alarm indicator is triggered by cable –E_AI6.

If the short circuit occurs at position 8 on the connection diagram, the alarm indicator will no longer be triggered.

As an option, the alarm indicator may also be connected using cable –E_AI5.

In this case, the alarm indicator will correctly indicate an alarm even if a short circuit occurs at position 8.

Therefore, this ensures that the alarm indicator will always function correctly.



The option described is possible in loop lines only.



To ensure product safety performance, please do not modify the product!

Dimensions

Unit: In mm

Without base

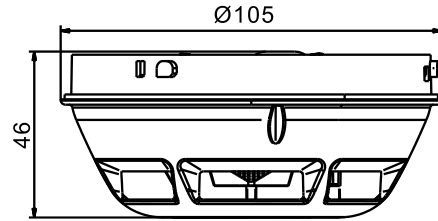

With base

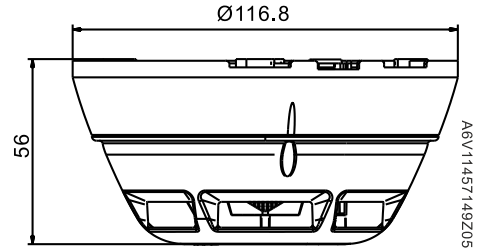

Maintenance

Regular performance checks of the detectors are required. A test gas/smoke generator can be used for the function check.

Recommendations:

All detectors are visually inspected once a year and those that are heavily contaminated and mechanically damaged must be replaced.

It is recommended that detectors that have been in use for 12 years be replaced, regardless of the environment.

Do not dispose of the product at will after the end of its life. Dispose of it in accordance with relevant national regulations such as the "Regulations on the Administration of Waste Electrical and Electronic Products Recycling and Disposal".



Risk of false alarms if heavily contaminated products are not replaced timely!

Technical data

Operating voltage	DC 13...33 V
Quiescent current	250 μ A
Electromagnetic compatibility at:	
10 KHz~1 GHz	50 V/M
1 GHz~2.7 GHz	30 V/M
Operating temperature	-10...+55 °C
Storage temperature	-20...+75 °C
Humidity	\leq 95 % rel.
Communication protocol	C-NET
Color	Pure white, RAL9010

Ordering Information

Type	Material no.	Designation	Weight
OP722-CN	S54310-F16-A1	Smoke detector	0.087 kg
DB721-CN	S54319-F12-A101	Detector base (with loop contact)	0.050 kg

Beijing Siemens Cerberus Electronics Ltd.
 Smart Infrastructure
 No.1 Fengzhidonglu, Xibeiwang, Haidian District
 Beijing, China
 100094
 +86 400 150 6060
 www.siemens.com/buildingtechnologies

© Siemens 2025

Data and design subject to change without notice.