

171 Series 2-Way Tri-Clamp Stainless Steel Ball Valves



Description	The 171 Series 2-way tri-clamp stainless steel ball valves are coupled with Siemens ball valve actuators to provide equal percentage flow control. The ball valves are 1/4-turn rotary control valves and are available in DN 15 (1/2") to DN 50 (2") line sizes
--------------------	--

-
- | | |
|-----------------|---|
| Features | <ul style="list-style-type: none">• PN16 pressure class with ISO 2852 end connection• Stainless steel wetted parts to ensure purity of media• Reinforcing ribs to ensure robust performance at high pressure• 87 psi close-off with ANSI Class IV leakage for all line sizes and actuators• Actuator mounts directly to valve for easy and quick installation• Valves are paired with fail-in-place actuator with quick 30 second runtime• Operating handle for manual operation• Suitable for use with modulating controllers (DC 0/2...10 V)• Compact assembly design allows for installation in tight spaces |
|-----------------|---|

Application	Siemens tri-clamp ISO 2852 stainless steel ball valves are purpose-built for liquid cooling applications in data centers. Designed for reliable and efficient flow control, these valves help meet demanding cooling requirements while preserving medium purity to ensure safe, stable, and high-performance operation of liquid cooling systems.
--------------------	--

WARNING:		Personal injury or loss of life may occur if you do not perform a procedure as specified.
CAUTION:		Equipment damage may occur if you do not perform a procedure as specified.

Product Numbers	Use the product numbers in Table 1 to order a valve and actuator assembly. The assembly product number consists of a 4-character actuator prefix code, a hyphen, and a 5-digit valve body suffix code. The "S" suffix denotes that the trim is stainless steel.
------------------------	---

Specifications	Body	304 stainless steel
	Ball	304 stainless steel
	Material	
	Ball seals	PTFE
	Flow characterizer	304 stainless steel
	End connections	ISO 2852 tri-clamp
	Stem	304 stainless steel
	Stem seals	EPDM O-rings
	Maximum operating differential pressure	50 psi (350 kPa)
Operating	Valve body rating	PN 16
	Media temperature	-4°F to 176°F (-20°C to 80°C)
	Controlled medium	Water, water-glycol solutions to 50%
	Angle of rotation	0° to 90°
	Close-off rating	87 psi (600 kPa) (ANSI Class IV)
Miscellaneous	Mounting location	NEMA 1 (interior only)
	Dimensions, service envelope, weight	See Figure 5 and Table 2.

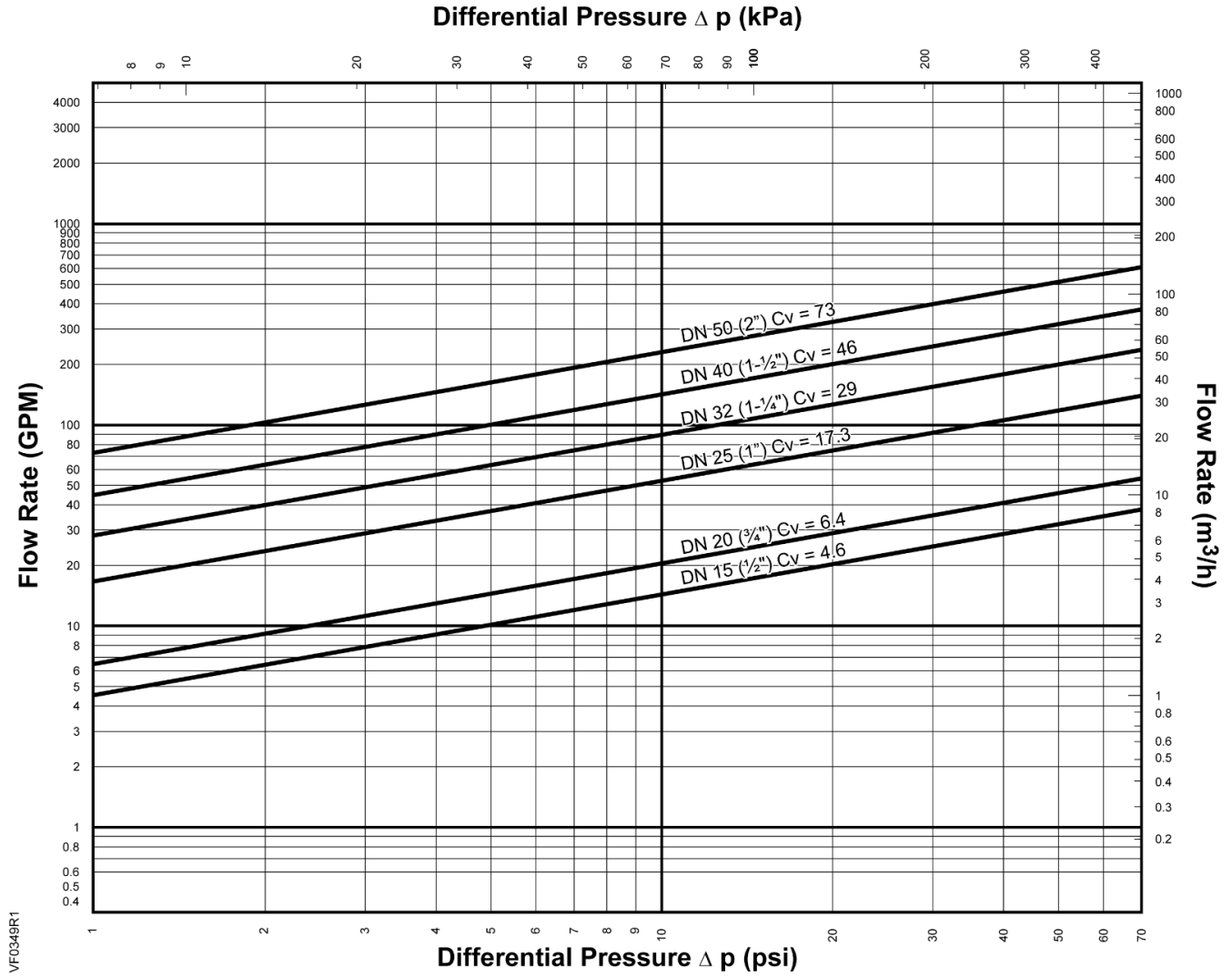



Figure 1.

Table 1. Fail-In-Place Assemblies: 304 Stainless Steel Ball and Stem (DN15 to DN50)

2-Way Valve Body Product Number	Valve Size Inches (DN)	Flow Rate Cv (Kvs)	Close-Off ΔP in psi (kPa)	Fail-in-Place
				
				0/2 to 10 Vdc
				S55499-D992 (GLD161.9Y/101)
				Actuator Prefix Code
				171X
S55232-V117	1/2 (15)	4.6 (4)	87 (600)	171X-10700S
S55232-V118	3/4 (20)	6.4 (5.5)		171X-10701S
S55232-V119	1 (25)	17.3 (15)		171X-10702S
S55232-V120	1-1/4 (32)	29 (25)		171X-10703S
S55232-V121	1-1/2 (40)	46 (40)		171X-10704S
S55232-V122	2 (50)	73 (63)		171X-10705S

Operation

The parabolic shape of the flow characterizer orifice (Figure 2) provides a slowly opening valve. Equal movements of the valve stem, at any point of the flow range, change the existing flow an equal percentage regardless of the existing flow. The ball valve equal percentage flow characteristic (Figure 3) mirrors the flow characteristic of a coil, resulting in linear heat transfer.

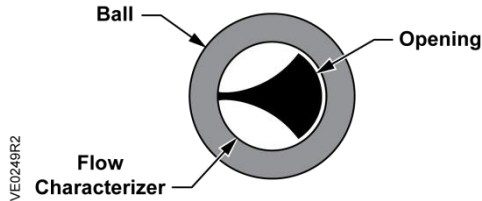

Figure 2. Ball Valve Flow Characterizer.

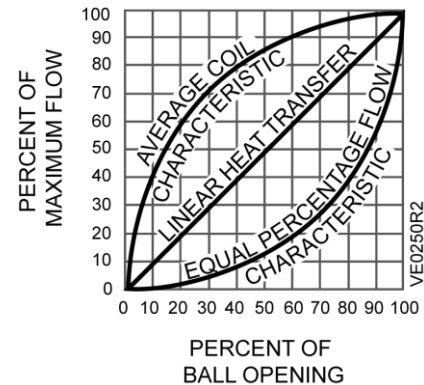

Figure 3. Ball Valve Equal Percentage Flow Control.

Mounting and Installation

Install the valve so that the flow follows the direction of the arrow cast on the valve body.

For added flexibility, the actuator mounting plate can be installed in any of the four (4) rotation angles relative to the valve body.

For best performance, install the valve assembly with the actuator above the valve body.

The valve and actuator assembly can be installed in a horizontal pipe in any position between vertical and 90°.

The ball valve also can be installed vertically.



CAUTION:

Do not install the valve assembly so that the actuator is below horizontal or upside-down.

Allow sufficient space for servicing the valve and actuator. See Figure 5 and **Error! Reference source not found.** for valve body dimensions and service envelope.

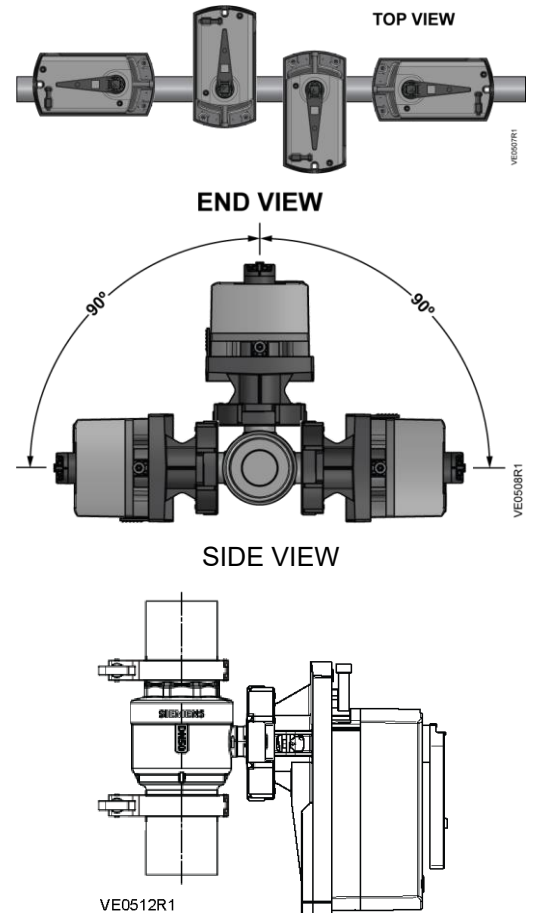

Figure 4. Mounting Positions.

Service

Replace the valve or actuator if inoperable.

Dimensions

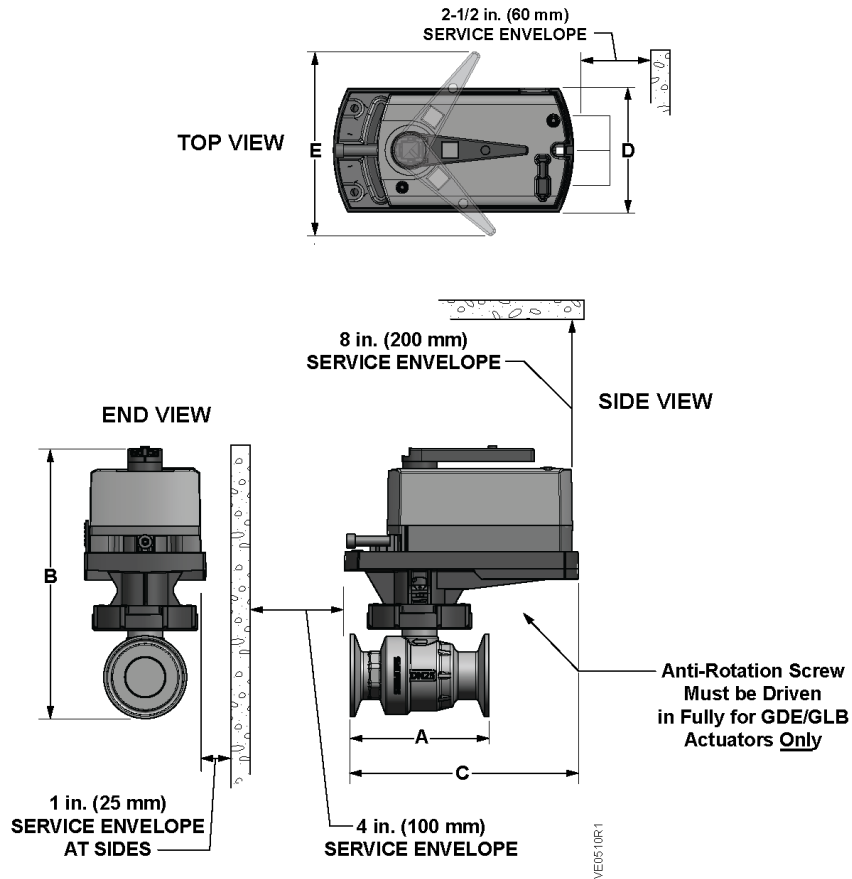

Figure 5. Two-Way Ball Valve and Low-Profile Bracket with Actuator Dimensions in Inches (Millimeters).

Table 2. Two-Way Ball Valve and Actuator Dimensions

Line Size Inches (DN)	Flow Rate Cv (Kvs)	A Length in Inches (mm)	B Height in Inches (mm)	C Length in Inches (mm)	D Width in Inches (mm)	E Width in Inches (mm)
1/2 (15)	4.6 (4)	3.3 (84)	5.82 (147.9)	5.64 (143.2)	2.9 (73.8)	4.0 (101.2)
3/4 (20)	6.4 (5.5)	3.3 (84)	5.87 (149.2)	5.64 (143.2)	2.9 (73.8)	4.0 (101.2)
1 (25)	17.3 (15)	3.3 (84)	6.54 (166.2)	5.64 (143.2)	2.9 (73.8)	4.0 (101.2)
1-1/4 (32)	29 (25)	3.3 (84)	6.67 (169.4)	5.64 (143.2)	2.9 (73.8)	4.0 (101.2)
1-1/2 (40)	46 (40)	3.7 (93.5)	7.30 (185.4)	5.80 (147.3)	2.9 (73.8)	4.0 (101.2)
2 (50)	73 (63)	3.8 (97)	7.65 (194.4)	5.84 (148.3)	2.9 (73.8)	4.0 (101.2)

Information in this publication is based on current specifications. The company reserves the right to make changes in specifications and models as design improvements are introduced. Other product or company names mentioned herein may be the trademarks of their respective owners. © 2026 Siemens Industry, Inc.