

## AO-P Module and Connector Block

### Product Description

The Analog Output Pneumatic (AO-P) module provides a single pneumatic control point for the Modular Building Controller (MBC) and Remote Building Controller (RBC).

The AO-P Point Termination Module (PTM) consists of a separate electronic point module and a mating connector block (Figure 1).

### Product Numbers

PTM6.1PSI20-M One Analog Output—Pneumatic with Manual Override

545-021 Replacement PTM6.1PSI20-M AOP Point Module Only

545-020 Replacement PTM6.1PSI20-M AOP Connector Block Only

### Accessories

545-825 APOGEE Address Keys, 1-16

545-826 APOGEE Address Keys, 17-32

545-827 APOGEE Address Keys, 33-48

545-828 APOGEE Address Keys, 49-64

545-829 APOGEE Address Keys, 65-80

545-040 pre-APOGEE Address Keys, 004-064

545-041 pre-APOGEE Address Keys, 068-128

545-042 pre-APOGEE Address Keys, 132-192

545-043 pre-APOGEE Address Keys, 196-256

545-044 pre-APOGEE Address Keys, 260-296

545-053 Identification Labels (12 per sheet)

### Caution Notation

<b>CAUTION:</b>		Equipment damage or loss of data may occur if you do not follow the procedures as specified.
-----------------	---	--

### Required Tools

- Cutters for pneumatic tubing
- Tie-wraps

### Expected Installation Time

10 minutes per module

### Prerequisites

- MBC or RBC mounted and AC power connected.
- Pneumatic tubing installed.
- Identification labels and job layout sheet printed.

**NOTE:** Module identification labels and layout sheets are generated in the field office by the Field Workstation and are typically supplied for each MBC/RBC enclosure.

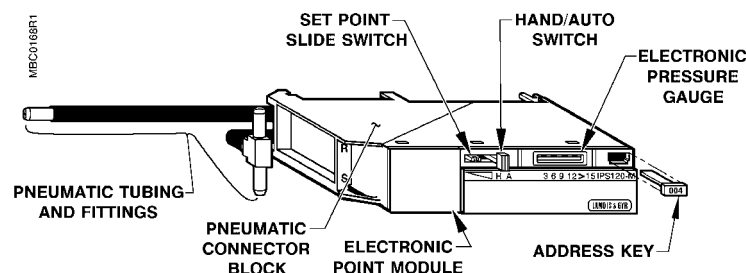

Figure 1. AO-P Point Module and Connector Block.

## Installation

**NOTE:** All PTMs have a piece of color-coded tape affixed to the right side of the identification window to identify the module type. AO-P modules have pink tape.

### Inserting the Module Labels

Do the following for each AO-P module being installed:

1. Use the point module address (for example, 2.0.1.1) to identify the correct label on the label sheet. For example:

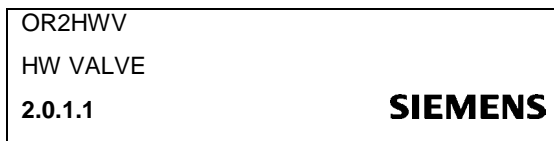

**NOTE:** If pre-addressed labels have not been supplied, identify each point module by legibly writing the following information for each point on the paper label: Name, Description, and Address.

2. Remove the label from the perforated sheet.
3. Fold the label to double thickness and insert it into the slot on the left side of the module (Figure 2).

The label should fit snugly under the module identification window.

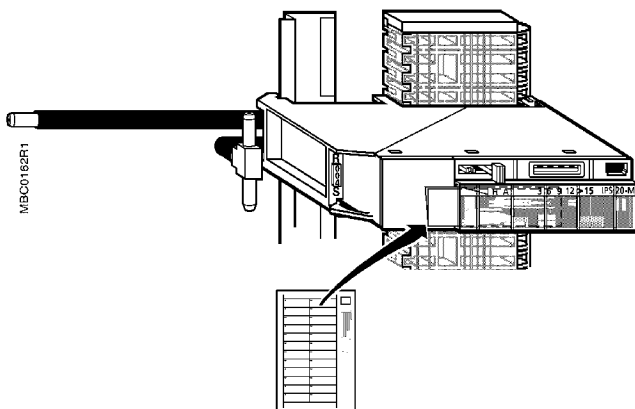

Figure 2. Labeling the Point Module.

### Inserting Address Keys and Address Markers

An address key is inserted into each AO-P point module to provide a unique address to both the Open Processor and the point database.

An address marker snaps into each connector block. Should it become separated from the point module, use the address marker to match the connector block to the appropriate point module.

**NOTE:** APOGEE address keys are sequentially numbered (for example, 001, 002, etc.). Pre-APOGEE address keys are numbered in multiples of 4 (for example, 004, 008, etc.).

Do the following for each AO-P module and connector block being installed:

1. Match point module address with the corresponding address key.

For example, module address 2.0.1.1 uses key number 001.



#### CAUTION:

The point address on the front label must be the same as the address key number.

2. Detach the appropriate address key from the spine.
3. Insert the address key into the slot located in the upper right corner of the point module (Figure 3).
4. Snap the address marker into the connector block (Figure 3).

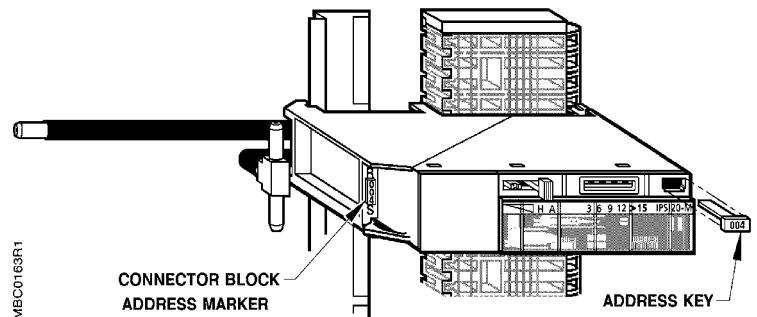

Figure 3. Inserting the PTM Address Key and Marker.

## Installing the Connector Block

Do the following for each connector block being installed:

1. Use the MBC/RBC layout sheet to determine the correct block position number.  
 The block position number is printed on the mounting rail label as 1A, 2A, etc. (Figure 4).
2. Remove the protective tape along the perforations to uncover the slot where the connector block attaches to the Module BUS (M-BUS).
3. Align the connector block mounting hooks with the left edge of the mounting rail.
4. Rotate the free end of the connector block into the M-BUS rail.
5. Verify that the mounting guides on the connector block are aligned with the mating M-BUS rail slot (Figure 4 and Figure 5).
6. Firmly press the connector block into the M-BUS rail.

You will hear a light “click” when the connector block is properly mounted”



### CAUTION:

The connector block should easily snap into place. If not, recheck the alignment of the mounting guides with the M-BUS rail.

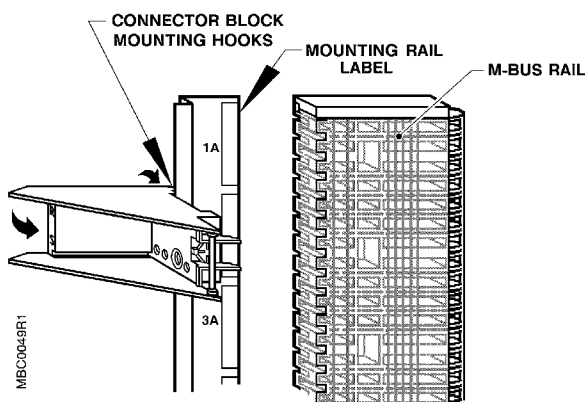

Figure 4. Installing a Connector Block.

## Repositioning or Removing a Connector Block

While pushing and holding the release tab toward the mounting rail, rotate the block out of the M-BUS rail (Figure 5).

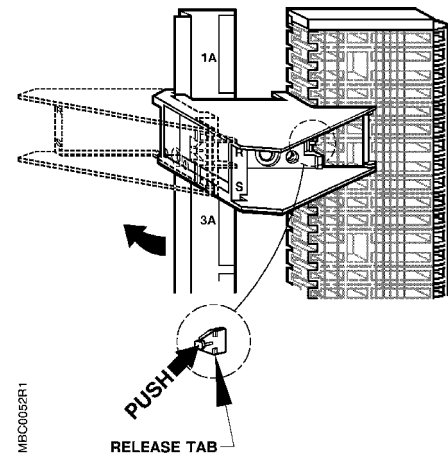

Figure 5. Removing a Connector Block.

## Connecting the Pneumatic Lines

**NOTE:** If more than one AO-P module is being used, you may daisy chain the supply lines. Up to four connector blocks can be supported by one 1/4-inch supply line.

1. Connect Supply air (S) to the open end of the brass tee fitting.  
 Allow 5 psig (34.5 kPa) supply above the maximum output value.
2. Insert a brass plug into the supply air extension of the last connector block. See Figure 6.
3. Connect the Return line from the controlled device to the Return port (R) of the AO-P connector block.

**NOTE:** To eliminate oscillation in the line, a minimum of 30 inches of 1/4-inch tubing is required between the AO-P return (R) port and the controlled device.

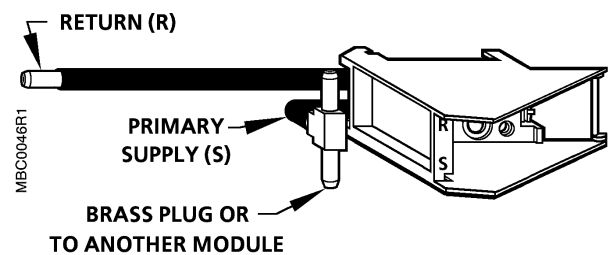

Figure 6. AO-P Connector Block Tubing Connections.

## Installing the AO-P Module

Do the following for each AO-P module being installed:

1. Use the MBC layout sheet and address keys and markers to match the AO-P module to the appropriate connector block.
2. Remove any M-BUS protective tape that was not removed when the connector block was installed.
3. Align the AO-P module mounting guides with the right edge of the M-BUS rail (Figure 7).
4. Rotate the free end of the module so that it mates with the previously installed connector block.
5. Verify that the module is aligned with the connector block and firmly press the AO-P module into place.

The AO-P module snaps into the connector block with a light “click.”



### CAUTION:

The AO-P module should easily snap into place. If not, recheck the alignment of the mounting guides with the M-BUS rail.

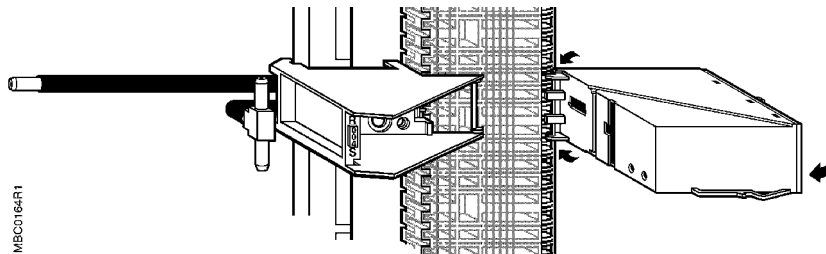

Figure 7. Installing an AO-P Module.

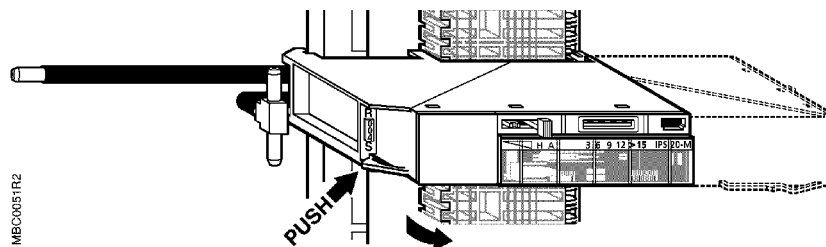

Figure 8. Repositioning or Removing an AO-P Module.

## Repositioning or Removing an AO-P Module

1. While pressing the AO-P module toward the connector block, push the module housing release tab located on the left side of the AO-P (Figure 8).
2. Tilt the AO-P module out of the M-BUS rail (shown in Figure 8).

## Completing the Installation

1. Leave the layout sheet in the literature pocket located at the bottom of the enclosure.
2. Use tie-wraps to secure Return (R) line(s) to the cable tie bar.

## For MBCs with Styled Doors and RBCs with Windowed Doors

Remove the perforated blank-out papers from the view panel to expose each AO-P module location.

The installation is now complete.

Information in this publication is based on current specifications. The company reserves the right to make changes in specifications and models as design improvements are introduced. Other product or company names mentioned herein may be trademarks of their respective owners. © 2004 Siemens Building Technologies, Inc.