

# SIEMENS





10562p01

## **TX-I/O™** **Engineering and installation guide**

**For Desigo V2.37, V4 and later, and Simatic S7**

# Contents

---

1	Introduction .....	5
1.1	Revision history .....	5
1.2	About this manual .....	6
1.3	Other applicable documents .....	7
1.4	Before you start .....	7
1.5	TX-I/O™ terms and definitions .....	9
1.6	Compatibility .....	10
1.6.1	Signal types, building automation and control systems .....	10
1.6.2	Further functions .....	12
1.7	Where are the TX-I/O™ modules used? .....	13
2	Safety guidelines .....	14
2.1	Cyber security disclaimer .....	14
2.2	General regulations .....	14
2.3	System-specific regulations .....	15
2.4	Specific regulations for TX-I/O devices .....	17
2.4.1	 Safety notes for engineering .....	17
2.4.2	Wiring safety notes .....	17
2.4.3	 Connecting field devices to I/O modules .....	18
2.4.4	Connection of a PC (tool) to a P-bus BIM .....	19
3	TX-I/O™ module system and accessories .....	20
3.1	The I/O modules in the control panel .....	20
3.2	The TX-I/O™ module system .....	21
3.3	The I/O modules .....	22
3.3.1	Construction .....	22
3.3.2	Mechanical features .....	23
3.3.3	Electrical characteristics .....	24
3.3.4	Indicators and operator controls .....	24
3.4	TXS1.12F10 power supply module and TXS1.EF10 bus connection module .....	25
3.4.1	Construction of the devices .....	25
3.4.2	Electrical characteristics .....	26
3.4.3	Indicators and operator controls .....	26
3.5	Island bus expansion module TXA1.IBE .....	27
3.5.1	Design .....	27
3.5.2	Electrical properties .....	27
3.6	Accessories .....	28
3.6.1	Bus covers .....	28
3.6.2	Address key .....	28
3.6.3	Module labeling .....	29
4	TX-I/O™ mounting instructions .....	30
4.1	Before you start .....	30
4.2	Structure or an I/O island .....	31
4.3	Structure of the I/O rows .....	31
4.4	Replacing a module .....	33
4.5	Replacing a bus interface module .....	34

4.6	Labeling and addressing the modules .....	35
4.6.1	Procedure and label allocation.....	35
4.6.2	Labeling the I/O modules .....	35
4.6.3	Addressing.....	36
5	Control panel.....	37
5.1	Control panel requirements.....	37
5.2	Physical layout.....	37
5.2.1	Orientation .....	37
5.2.2	Grouping and order of modules .....	38
5.2.3	Space requirements.....	38
5.3	EMC compliant control panel .....	40
6	Wiring.....	41
6.1	Before you start.....	41
6.2	General notes .....	41
6.3	Screw terminals .....	42
6.4	Wiring of AC 24 V and bus.....	43
6.4.1	Wiring for AC 24 V .....	44
6.4.2	Wiring for the island bus (module supply DC 24 V) .....	45
6.4.3	Wiring island bus expansion .....	46
6.5	Wiring examples .....	47
6.5.1	Principles .....	47
6.5.2	Example: 1 transformer, 1 or 2 control panels .....	48
6.5.3	Example: 2 transformers, 1 or 2 control panels .....	48
6.5.4	Example: New power supply (module supply or AC 24 V) .....	48
6.5.5	Example: New supply (field supply $V_{\sim}$ , AC/DC 12 ... 24 V).....	49
6.6	Connecting the field devices .....	50
6.7	EMC compliant wiring .....	51
7	Checking activities .....	53
7.1	Location and installation of equipment .....	53
7.2	Power supply .....	54
7.3	Labeling and addressing.....	54
7.4	Wiring test with unconfigured I/O modules .....	55
7.5	Other function checks .....	56
7.6	Control panel delivery check.....	56
8	Commissioning notes.....	57
8.1	Response on module start-up.....	57
8.2	Response after reset.....	58
8.3	Response in other states .....	58
9	Display, operation, and diagnostics .....	59
9.1	Indication and display of the I/O modules .....	59
9.2	Indication and display of the other island bus devices.....	62
9.3	Local override .....	64
9.3.1	Override button .....	64
9.3.2	Override status LED.....	64
9.3.3	Priority.....	64

9.4	Display .....	65
9.4.1	Overview: indication per signal type / I/O function .....	65
9.4.2	LED behavior .....	66
9.4.3	General: LCD graphics.....	67
9.4.4	Start-up and reset response.....	67
9.5	Diagnostics based on the LED indicators – (integration via island bus) .....	68
9.6	Diagnostics based on the LED indicators – Integration via P-Bus BIM.....	70
9.7	Diagnostics on the PROFINET BIM .....	72
10	Principles of electrical design .....	73
10.1	Definitions .....	73
10.2	Voltage and current limits.....	75
10.3	Admissible number of devices .....	77
10.4	Cables for AC 24 V .....	78
10.5	Cables for the island bus (DC 24 V).....	80
10.5.1	Max. cable lengths for island bus .....	83
10.5.2	Installation rules for island bus .....	84
10.5.2.1	Examples without any remote supplies .....	85
10.5.2.2	Examples with 2 remote supplies (2 sub-islands) .....	87
10.5.2.3	Examples with 4 remote supplies.....	88
10.5.2.4	Multiple supplies.....	89
10.6	Island bus expansion .....	90
10.6.1	Benefits of island bus expansion.....	90
10.6.2	Limits .....	90
10.6.3	Restrictions .....	90
10.6.4	Island bus expansion cable material .....	91
10.6.5	Installation rules for island bus expansion .....	93
10.6.6	Wiring examples for island bus expansion.....	96
10.6.7	Installation examples for island bus expansion.....	99
10.7	Cables for field devices .....	102
10.8	Consumption data DC 24 V .....	102
10.9	AC 24 V transformer sizing .....	103
10.10	Fuses .....	104
10.11	Digital inputs (status and counting) .....	105
10.12	Analog inputs .....	106
10.12.1	Passive resistance sensors and resistance transmitters (2-wire connection) .....	106
10.12.2	Correcting the line resistance with [Icpt].....	110
10.12.3	Active sensors DC 0 ... 10 V.....	112
10.12.4	Current inputs.....	113
10.12.5	Technical data for the analog inputs .....	114
10.13	Wiring for Triac outputs AC 24 V.....	116
10.14	Wiring for Relay outputs.....	117
10.15	Analog outputs .....	118
11	Disposal .....	120

# 1 Introduction

## 1.1 Revision history

March 2026 Revision_16	<b>TXM1.4D3R added</b> <b>TXI1.OPEN replaced by TXI2(-S).OPEN</b>
July 2023 Revision_15	Section "Revision history": Links to chapters updated where necessary. Section "Other applicable documents": Added PXC4, PXC5 & PXC7 Planning overview and Range description. Term "bus master" changed to "bus manager"
April 2020 Revision_14	Editorial changes, Installation location 'island bus' specified (section 1.7)
May 2019 Revision_13	Power supply modules and BIMs: Internal fuse M 10A
July2013 Revision_12	Voltage drop and cable lengths (sections 10.2, 10.4, 10.12, 10.13, 10.14, 10.15)
Nov.2013 Revision_11	Triacs: voltage drop and cable lengths (sections 10.2, 10.13, 10.14)
Feb.2013 Revision_10	Wiring of field devices in sections 6.3, 6.6, 10.12.3, 10.13
Nov.2012 Revision_09	Type designations in section 9.2
Mar.2012 Revision_08	Amendments concerning TXM1.8T and TXM1.8RB Amendments concerning TRA and PXC3... Changed designation of signal types (overview see section 1.6.1)
Jul.2010 Revision_07	Amendments concerning TXM1.6RL Section 0 and in other sections: Information on support of TX I/O functions in different building automation and control systems, new including Simatic S7
12 May 2009 Revision_06	Section 1.4: Intranet address Section 10.12.5: Note on open circuit detection with U10
31 Jan 2009 Revision_05	Amendments concerning V4 (direct island bus integration)
19 Aug 2008 Revision_04	Amendments concerning island bus expansion (sections 3.5, 6.4.3, 9.3, 10.7)
31.01.2008 Revision_03	Sections 10.5 and 10.10: various small corrections
22.11.2007 Revision_02	Replaced Section 10 (Island bus wiring)
30.03.2007 Revision_01	First edition

## 1.2 About this manual

---

### Key target groups

- Project managers
- Consulting engineers
- Service engineers
- Control panel manufacturers and their staff
- Electricians

### Contents

This manual contains information on:

- Planning, mounting and wiring the TX-I/O modules
  - Control-panel sizing
  - Safety and EMC (electromagnetic compatibility) precautions
  - Connecting the power supply, island bus and field devices
  - Display, operation, and diagnostics.
  - Support of TX I/O functions in different building automation and control system
- For plant-specific mounting and wiring information please refer to the relevant project documentation.

## 1.3 Other applicable documents

	Document	Number
[1]	TX-I/O™ Range overview	CM2N8170
[2]	TX-I/O™ Module data sheets	CM2N8172 ff
[3]	TX-I/O™ Power supply module / bus connection module data sheet	CM2N8183
[4]	TX-I/O™ Functions and operation	CM110561
[5]	P-bus bus interface module data sheet	CM2N8180
[6]	PROFINET BIM data sheet	CM2N8186
[7]	Replacement of legacy modules	CM110563
[8]	Island bus expansion module	CM2N8184
[9]	PROFINET BIM Operator's manual	CM110564
[10]	PXC3... data sheet	CM1N9203
[11]	PXC4, PXC5 & PXC7 Planning overview <sup>1)</sup>	A6V13054435
[12]	PXC4, PXC5 & PXC7 Range description <sup>1)</sup>	A6V13054432

<sup>1)</sup> In the documents PXC4, PXC5 & PXC7 Planning overview and Range description you find information about the integration of TX-I/O modules into PXC4, PXC5, and PXC7 installations.

Note The documents listed in the table are available on the intranet via the document information system, STEP.

## 1.4 Before you start

---

### Copyright notice

This document may be duplicated and distributed only with the express permission of Siemens, and may be passed only to authorized persons or companies with the required technical knowledge.

### Quality assurance notice

These documents have been prepared with great care.

- The contents of all documents are checked at regular intervals.
- Any corrections necessary are included in subsequent versions.
- Documents are automatically amended as a consequence of modifications and corrections to the products described.

Please ensure that you are aware of the latest revision date of the documentation. If you find any lack of clarity while using this document, or if you have any criticisms or suggestions, please contact the product manager in your nearest branch office. The addresses of the Siemens regional companies are available at [www.buildingtechnologies.siemens.com](http://www.buildingtechnologies.siemens.com).

**Document use /  
request to the reader**

Before using our products, it is important that you read the documents supplied with or ordered at the same time as the products (equipment, applications, tools etc.) carefully and in full.

We assume that persons using our products and documents are authorized and trained appropriately and have the technical knowledge required to use our products as intended.

More information on the products and applications is available:

- On the intranet (Siemens employees only) at <https://workspace.sbt.siemens.com/content/00001123/default.aspx>
- From the Siemens branch office near you [www.buildingtechnologies.siemens.com](http://www.buildingtechnologies.siemens.com) or from your system supplier
- From the support team at headquarters [fieldsupport-zug.ch.sbt@siemens.com](mailto:fieldsupport-zug.ch.sbt@siemens.com) if there is no local point of contact

Siemens assumes no liability to the extent allowed under the law for any losses resulting from a failure to comply with the aforementioned points or for the improper compliance of the same.

## 1.5 TX-I/O™ terms and definitions

Term	Description
Bus manager	Device with supervisory function for an assigned set of I/O devices. <b>Desigo TRA:</b> Room automation station; <b>DESIGO V4:</b> automation station or bus interface module (BIM); <b>DESIGO V2.37:</b> P-bus interface module (BIM); Simatic S7: PROFINET BIM
Island bus (TX-I/O module bus)	<ul style="list-style-type: none"> <li>• Communications bus between the bus manager (room automation station, automation station or bus interface module) and the connected TX-I/O modules.</li> <li>• Simultaneously carries the supply voltages for the modules and the field devices</li> <li>• The bus is created automatically through the interconnection of the TX-I/O modules.</li> </ul>
Island bus expansion	The island bus expansion modules allow "decentralized" sub-islands using TX-I/O modules that can be located up to 2 x 200 m from each other.
Power supply module	"Active" power supply module that converts AC 24 V to DC 24 V. It supplies power for operation of the module electronics and of DC 24 V and AC 24 V field devices)
Bus connection module	"Passive" module which passes communication signals and DC 24 V between multiple I/O rows and/or serves as a connection point for additional AC / DC 12 ... 24 V supply for field devices.
Bus interface module (BIM)	Interface between the island bus and another bus. Acts as an island bus manager.
P-bus BIM	Interface between a P-Bus automation station (Desigo, Unigr, Visonik) and the island bus.
PROFINET BIM	Interface between a PROFINET system and the island bus.
I/O island	All TX-I/O devices that are physically connected to the same island bus segment and linked to the same bus manager.
Sub-island	Local, remote, decentralized sub-islands: see sections 10.5.2, 10.6.5
I/O row	One I/O island may consist of several rows of modules, each referred to as an "I/O row". Each I/O row starts either with a bus manager, or a power supply module, or a bus connection module.
I/O module (assembly)	Device in which the physical signals from the field devices are converted into software process values and vice versa. An I/O module has a specific number of I/O points, determined by the module type. The I/O module assemblies (normally called I/O modules) consist of a terminal base and a plug-in module.
I/O point	Smallest addressable unit in an I/O module. One or more I/O points (e.g. three-stage switching output) correspond to each data point /channel on the room automation station / the automation station.
Terminal	The cables of the field devices (field devices) are connected to the terminals.
Plug-in module	The plug-in component with the module electronics that can be removed from the terminal base.
Terminal base	The base unit for the TX-I/O module, which is mounted on the standard mounting rail and to which the wiring is connected. The terminals have the function of control panel terminal strips.
Address key	Accessory, which must be plugged into the plug-in module. The module address is assigned via the mechanical coding of the key.
Reset key	Serves to reset the module function to the factory state. Is inserted in place of the address key and can then be removed.
I/O function	The function of an I/O point, which determines how it operates (e.g. signal input, 0...10 V voltage output etc.). Certain functions may use more than one I/O point (e.g. multi-stage switching output).
Signal type	Designation of the signal of a physical input / output
TRA	Desigo Room Automation
Addressing	From the perspective of the building automation and control system, the module address consists of a module number (range 1...120) and an I/O point number (range 1...16).
Local override, tool override, "functional test" etc.	Each building automation and control system has its own tools.

# 1.6 Compatibility

## 1.6.1 Signal types, building automation and control systems

This document describes the full functionality of the TX-I/O module system. Depending on the building automation and control system not all functions are supported, especially when the integration is made via a bus interface module.

### Labeling in this document

- **P-Bus BIM** designates functions / restrictions that are valid for integration via P-bus BIM (Desigo V2.37 and later).
- **PROFINET BIM** designates functions / restrictions that are valid for integration via PROFINET BIM (Simatic S7 300/ 400).
- **TRA**: Desigo Room Automation (Desigo TRA).  
→ These functions are only supported by TX-I/O modules from series D.

The following table shows the support and designation of signal types in different building automation and control systems. Gray = not supported / partially supported.

Description	Support by building automation and control system						
	Desigo Room Automation V5 and later Signaltype (BACnet object type)	Desigo V5 and later Island bus integration	DESIGO V4, V4.1 Island bus integration	DESIGO V2.37 and later Integration via P-Bus-BIM	Simatic S7 300/ 400 Integration via PROFINET BIM	UNIGYR V3 and later VISONIK BPS V12 and later PRV1 V6 and	
Digitale inputs							
Status indication, volt-free maintained contact, N/O, N/C contact	BI NO (BI)	D20	D20	D20	BI_STATIC	D20	
	BI NC (BI)	2)	2)	D20R	BI_STATIC	D20R	
Status indication, volt-free pulsed contact, N/O, NC contact (with storage function)	BI Pulse NO (BI)	D20S	D20S	D20S	BI_PULSE	D20S	
	BI Pulse NC (BI)	2)	2)	2)		2)	
Pushbutton input, single / dual, N/O, NC contact	BI Push NO 1) (Blsln, Lgtln)	(Use D20S) 3)					
	BI Push NC 1) (Blsln, Lgtln)						
Multistate input, 2...8 stage	MI Switch NO / NC 1) (MI)	(Use D20)					
Count, volt-free pulse contact, mechanical or electronic, normally open, max. 10 Hz, with debouncing max. 25 Hz, with debouncing electronic contact max. 100 Hz		C	C	C	CI_Limited		
		C	C	C	CI	C	
		C	C		CI		

Description	Support by building automation and control system						
	Desigo Room Automation V5 and later Signaltype  (BACnet object type)	Desigo V5 and later Island bus integration	DESIGO V4, V4.1 Island bus integration	DESIGO V2.37 and later Integration via P-Bus-BIM	Simatic S7 300/400 Integration via PROFINET BIM	UNIGYR V3 and later VISONIK BPS V12 and later PRV1 V6 and	
<b>Analog inputs</b>							
Temperature Pt100 Ω (4-wire)		Pt100_4	Pt100_4		AI_PT100_4		
Resistance 250 Ω (Pt 100)		P100 (4-Draht)	P100 (4-Draht)	P100 (4-Draht)		P100 (4-Draht)	
Resistance 250 Ω		R250 (2-Draht)	R250 (2-Draht)		AI_R250		
Temperature Pt 1000 (Europe)	AI PT1K385 (AI)	Pt1K 385	Pt1K 385		AI_PT1K385		
Temperature Pt 1000 (USA)	AI PT1K375 (AI)	Pt1K 375	Pt1K 375		AI_PT1K375		
Resistance 2500 Ω (Pt 1000)		P1K	P1K	P1K		P1K	
Temperature LG-Ni 1000, up to 180 °C		Ni1K	Ni1K		AI_Ni1K		
Temperature LG-Ni 1000	AI Ni1000 (AI)	R1K	R1K	R1K		R1K	
Resistance 2500 Ω	AI 2500 Ohm (AI)	R2K5	R2K5		AI_R2K5		
Temperature NTC 10 K	AI NTC10K (AI)	NTC10 K	NTC10 K		AI_NTC10 K		
Temperature NTC 100 K	AI NTC100K (AI)	NTC100 K	NTC100 K		AI_NTC100 K		
Temperature T1 (PTC)	AI T1 (PTC) (AI)	T1	T1	T1	AI_T1	T1	
Voltage DC 0 .. 10V	AI 0-10V (AI)	U10	U10	U10	AI_U10N	U10	
Current DC 4 .. 20 mA		I420	I420	I420	AI_I420	I420	
Current <b>DC 0...20 mA</b> (for 25 mA see CM10563)		I25	I25	I25	AI_I020	I25	
<b>Digital outputs</b>							
Maintained contact, relay, changeover switch <b>N/O, NC contact</b>	BO Relay NO 250V (BO) BO Relay NC 250V (BO)	Q250	Q250	Q250	BO_Q250	Q250	
Maintained contact, triac, output AC 24 V <b>N/O, NC contact</b>	BO Triac NO 1) (BO) BO Triac NC 1) (BO)	Q250_T 1)					
Maintained contact, bistable (for light applications), <b>N/O, NC contact</b>	BO Bistable NO (LgtBOut) BO Bistable NC (LgtBOut)	Q250B			BO_BISTABIL	Q250B	
Pulse	BO Pulse (BO)	(use MO Q250-P1)			BO_Q250_P		
Pulse On-Off, <b>N/O and NC contact</b>	BO Pulse On-Off (BO)	Q250-P / Q250A-P	Q250-P / Q250A-P	Q250-P / Q250A-P		Q250-P / Q250A-P	
Multistate maintained contact	MO Steps (1...6-stage) (BO)	Q-M1...M4	Q-M1...M4	Q-M3	MO(n)_STATIC (2 4-stufig)	Q-M3	
Multistate pulse		Q250-P1...P5	Q250-P1...P5	Q250-P3	MO(n)_PULSE n = 1...4	Q250-P3	
Pulse, control signal, three-position output, internal stroke algorithm (relay)	BO 3-Pos Relay (AO)	Y250T	Y250T	Y250T	AO_Y250T	Y250T	
Pulse, control signal, three-position output, internal stroke algorithm (Triac, AC 24 V)	BO 3-Pos Triac 1) (AO)	Y250T 1)					
Pulse width modulation, output AC 24 V	BO PWM 1) (AO)	PWM 1)					
Blinds control with 2 / 3 end switches	BO Blind Relay 1) (BlisOut)						
<b>Analog outputs</b>							
Proportional control signal DC 0...10 V	AO 0-10V (AO)	Y10S	Y10S	Y10S	AO_U10N	Y10S	
Proportional control signal DC 4...20 mA		Y420	Y420	Y420	AO_I420N	Y420	

1) Signal type is only supported by modules from series D.

2) Workaround for N/C contact: Use D20 and set "Polarity" = Indirect.

3) D20S for light / blinds: Consider reaction time / performance!

## 1.6.2 Further functions

Topic	V2.37	V4 and later	Simatic S7-300 / 400
Selection of functionality	Indirectly by selecting the automation station in XWP. A "new", island-bus capable automation station leads to other menus, where the V4 signal types and the corresponding parameters can be set.		Selected in S7 HW Config Tool
Integration of TX-I/O modules.	Via P-bus interface module (BIM)	Automation station directly supports the island bus	Via PROFINET BIM
Signal types		V4 supports additional signal types (See 1.6.1).	See 1.6.1
Tools (For details, see [6], [9])	The BIM tool generates the IOMD. The tool is now called the BIM Tool under <b>V4</b> .	Configuration takes place – In the Point Configurator – In the I/O Address Editor (in the CFC) And is saved as an IOC.	Configuration is done in S7 HW Config Tool and saved in S7 project
Download	The TX-I/O Tool loads the module configuration (IOMD) to the BIM (via USB). For BIM integration under V4 (XWP) this tool is called BIM Tool	Module configuration (IOC) is loaded to the automation stations with the CFC program. Or directly to the module using Desigo Point Test Tool via BACnet.	Is done in S7 HW Config when loading the S7 CPU
Addresses	The P-bus address (P=...) includes the parameters such as signal type, pulse length, etc.	The island bus address (T=...) does not include parameters, these are in the IOC. A signal type may occupy multiple addresses (e.g. multistate).	The island bus addresses are defined by address keys. S7 addresses and parameters are assigned to I/O channels in the S2 HW Config
Resolution of the process values	Resolution limited by the P-bus specification (nevertheless, better to some extent than for PTM-I/O)	Direct island bus integration allows for a higher resolution	Equal to island bus resolution
D20R	Signal types D20 and D20R may be selected	Only signal type D20 may be selected. The function D20R must be realized with <i>Polarity</i> in the I/O Address Editor (CFC).	Signal types D20 and D20R may be selected
C	Meter only up to 25 Hz	Select among – Mechanical meter (up to 25 Hz) – Electronic meter (up to 100 Hz) – Meter function: Meter is reset at power down Measure function: Meter state is stored at power down	
	Meter value storage only up to 64; serves to bridge the AS poll cycle.	Meter value storage up to $(2^{32})-1$ ( $\approx 4.3 \times 10^9$ )	
Pt100_4 P100 R250	Not supported. <b>BIM integration under V4</b> supports P100 4-wire as well as 250 Ohm 2-wire, but with jumpers connected to 4 terminals such as PTM-I/O. See datasheet N8176 for connection diagram.	Pt100_4 and P100 are connected with 4 wires, R250 with 2 wires.	Supports Pt100_4 with 4-wire connection and R250 with 2-wire connection
Multistate inputs	Are formed via a FW block and are compiled from multiple, individual I/O points		
Multistate outputs	Supports only Q-M3 and Q250-P3. Other types must be implemented via individual I/O points in the MO block. <b>(Caution, the associated I/O points can be individually operated, both locally on the module and using the tool!)</b>	The island bus knows native MOs. The associated I/O points cannot be individually operated locally, they are locked against one another.	S7 supports Q-M1...Q-M4 and Q250-P1...P4. The PROFINET BIM operates the MOs via individual S7 binary outputs. The associated <b>I/O points cannot be individually operated locally, they are locked against one another.</b>
Function test	Function test in the TX-IO Tool	Various possibilities, see CM110561	Test using the S7 Control / Status Variable tool
TX OPEN	Not supported	See separate documentation	Not supported

# 1.7 Where are the TX-I/O™ modules used?

In hardware terms, a typical building automation and control system includes the following three areas:

Area	Brief description
Management station (management level)	The management station is the workstation from which the operator manages and monitors all the building services plant in the building automation and control system.
<b>Control panel</b> (automation level, described in this document)	The control panel accommodates the following devices: <ul style="list-style-type: none"> <li>– Automation stations</li> <li>– Bus interface module</li> <li>– Power supply modules, bus connection modules</li> <li>– Island bus expansion module</li> <li>– I/O modules, connected via the island bus</li> </ul>
Building services (field level)	Refers to the connected equipment, e.g. heating, ventilation and air conditioning systems, electrical plant etc.

### Example: Designo

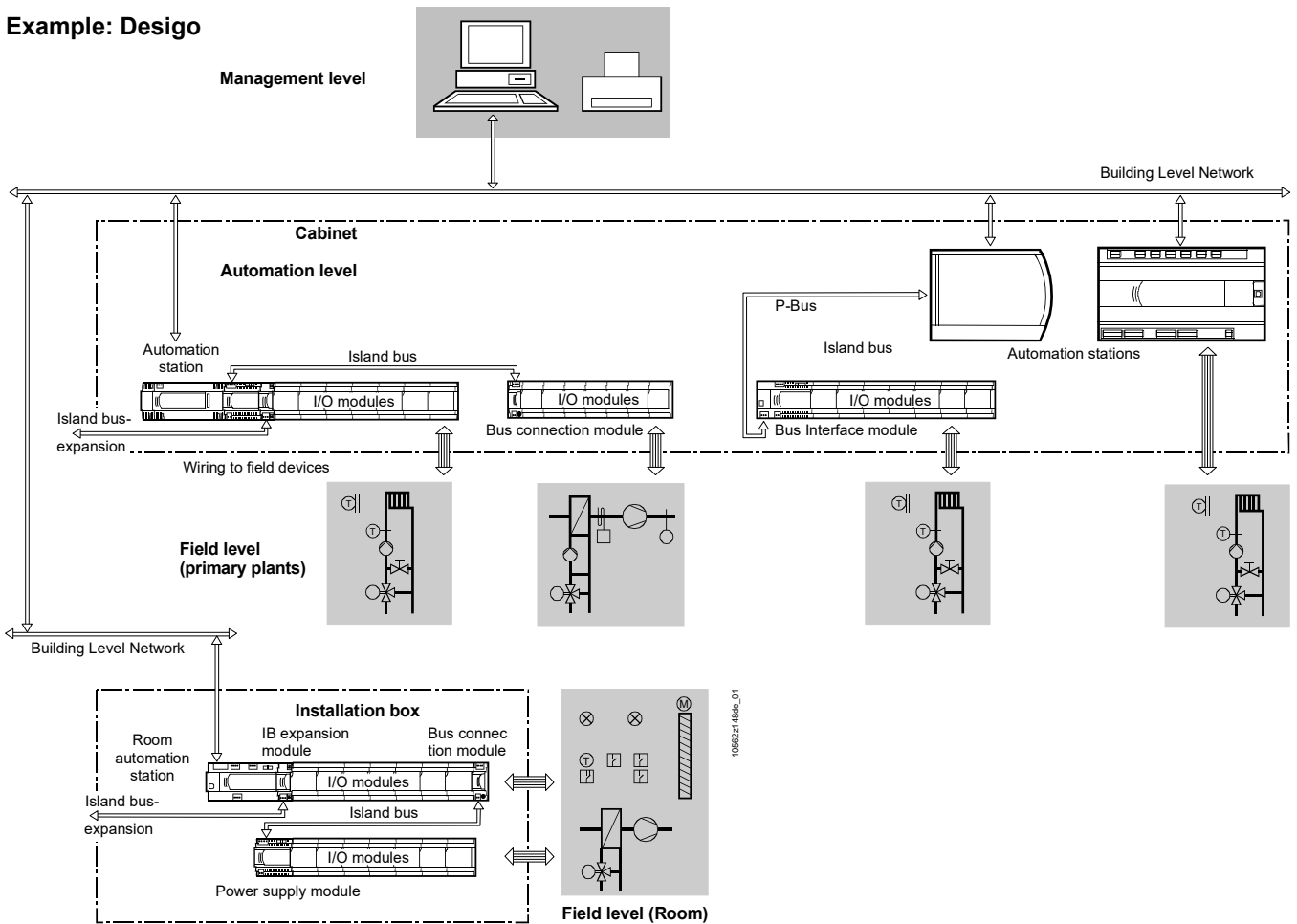

**⚠ Installation location island bus**

Island bus and island bus expansion are designed for indoor use in one building only.

**Note** Compatibility of island bus expansion with different series of TX-I/O devices: see section 10.6.3.

## 2 Safety guidelines

### 2.1 Cyber security disclaimer

---

Siemens provides a portfolio of products, solutions, systems and services that includes security functions that support the secure operation of plants, systems, machines and networks. In the field of Building Technologies, this includes building automation and control, fire safety, security management as well as physical security systems.

In order to protect plants, systems, machines and networks against cyber threats, it is necessary to implement – and continuously maintain – a holistic, state-of-the-art security concept. Siemens' portfolio only forms one element of such a concept.

You are responsible for preventing unauthorized access to your plants, systems, machines and networks which should only be connected to an enterprise network or the internet if and to the extent such a connection is necessary and only when appropriate security measures (e.g. firewalls and/or network segmentation) are in place. Additionally, Siemens' guidance on appropriate security measures should be taken into account. For additional information, please contact your Siemens sales representative or visit [Industrial Cybersecurity - Themenfelder - Deutschland \(siemens.com\)](https://www.siemens.com).

Siemens' portfolio undergoes continuous development to make it more secure. Siemens strongly recommends that updates are applied as soon as they are available and that the latest versions are used. Use of versions that are no longer supported, and failure to apply the latest updates may increase your exposure to cyber threats.

Siemens strongly recommends to comply with security advisories on the latest security threats, patches and other related measures, published, among others, under [CERT Services | Services | Siemens Global](#).

### 2.2 General regulations

---



**Please observe these notes**

This section contains general and system-specific regulations. It includes important information relevant to your own safety and the safety of the entire system.



**Safety note**

All instructions and notes that appear in this manual in conjunction with the triangle shown on the left **must be observed**. Failure to comply **puts personal safety and property at risk**.



**General regulations**

Observe the following general regulations for project engineering and implementation:

- Electricity and high-voltage power regulations applicable in the country concerned
- Other relevant country-specific regulations
- Building installation regulations for the country concerned
- Regulations of the energy supply company
- Diagrams, cable lists, plans, specifications and instructions supplied by the customer or engineering company
- Third-party regulations, e.g. from primary contractors or building owners.

## 2.3 System-specific regulations

### Safety

Electrical safety in the building automation and control systems supplied by Siemens Smart Infrastructure is essentially based on the use of **extra low voltage which is strictly segregated from the mains voltage**.

### SELV and PELV

Depending on the earthing arrangements, this low voltage is either SELV or PELV in accordance with HD 384 "Electrical installations in buildings":

**Unearthed** = **SELV** (Safety Extra Low Voltage)

**Earthed** = **PELV** (Protection by Extra Low Voltage)

**Mixing of SELV and PELV in a system is not permitted.**

### Equipment safety

Equipment safety is ensured by various strategies, including:

- Low voltage AC 24 V supply, either SELV or PELV
- Double insulation between AC 230 V mains voltage and SELV/PELV circuits
- Fine-wire fuse in the power-supplying units (P-Bus BIM, power supply module, bus connection module)
- Back-up fuses for the power-supplying units (P-Bus BIM, power supply module, bus connection module).

Always observe the specific regulations for the electrical wiring of the TX-I/O modules, as described in the following sections.

### Earthing of system neutral

Note the following in relation to the earthing of the reference point (*system neutral* (symbol  $\perp$ )):

- In principle, it is permissible for the reference point,  $\perp$  of the AC 24 V operating voltage to be either earthed (PELV) or unearthed (SELV). This decision is determined by local regulations and conventions.
- There may also be practical reasons which make earthing either compulsory or inadmissible.

### Recommendation: PELV

- **AC 24 V systems should generally be earthed (PELV)** unless otherwise specified.
- To avoid earth loops, ensure that systems with **PELV** are **earthed at one point** in the system only, usually at the transformer, unless otherwise specified.

### Mains and operating voltage

The following regulations apply to mains and operating voltage:

Item	Regulation
AC 230 V mains voltage	<ul style="list-style-type: none"> <li>• <b>Installation only by skilled professionals</b></li> <li>• <b>Installation only when mains supply is disconnected</b></li> </ul>
AC 230 V mains voltage protection	<ul style="list-style-type: none"> <li>• <b>Transformers, primary winding:</b> Control panel fuse (control fuse)</li> <li>• The mains voltage routed to the TX-I/O modules (<b>supply cable for relay contacts</b>) must be fused:               <ul style="list-style-type: none"> <li>– Max. 10 A (slow blow)</li> <li>– Max. 13 A (miniature circuit breaker)</li> </ul> </li> </ul>
Operating voltage	The operating voltage is AC 24 V. It must comply with SELV or PELV requirements to HD 384.
Specification for AC 24 V transformers	Double-insulated safety transformers to EN 61558, designed for continuous operation to supply SELV or PELV circuits.

Fuses to protect AC 24 V operating voltage

**Transformers, secondary winding:** based on the effective load of all connected devices in accordance with the transformer sizing:

- The AC 24 V conductor (system potential) must always be fused
- Where specified, an additional fuse must be provided for the reference conductor  $\perp$  (system neutral).

 **Important**

- The 10 A fine-wire fuses fitted to the power supply units to protect the I/O island are not a substitute for the load-dependent back-up fuse.

### Transformer sizing

Refer to Section 10.9.

#### **Beware of external voltages!**

The introduction of hazardous voltages into the low voltage circuits of the system (e.g. due to faulty wiring or to parasitic voltages in the TX-I/O modules) represents an immediate danger to personal safety and may cause irreparable damage to the building automation and control system.

#### **Overvoltage protection**

- Adhere to local regulations on lightning protection and equipotential bonding.
- Overvoltage protection devices can falsify the measured value of analog inputs.  
*Example:* Phoenix type PT 1X2-12DC-ST/28 56 02 9 has an internal protective impedance which causes a measuring error of +1K, but only for LG-Ni 1000 sensors.

#### **Explosion protection**

- Adhere to local regulations on Explosion protection.
- Explosion protection devices can falsify the measured value of analog inputs.  
*Example:* Pepperl & Fuchs type CFD2-RR-Ex19 causes considerable measuring errors for resistance values of <30 ohms. Resistances >30 ohms are measured correctly.

## 2.4 Specific regulations for TX-I/O devices

### 2.4.1 Safety notes for engineering

If you are responsible for the control-panel engineering, you should check that you have access to the documents listed in Section 1.3. Observe the engineering notes and safety regulations in these documents.

### 2.4.2 Wiring safety notes

#### Electrical isolation

Type	Electrical isolation
Relay outputs	Electrically isolated The insulation resistance between one relay output and another, and between the relay outputs and SELV/PELV, is AC 3750 V in accordance with EN 60730. The relay outputs are suitable for double or reinforced insulation. <b>Adjacent I/O points may, therefore, have different voltages (a mixture of mains and low voltage is permitted).</b>
I/O island	All TX-I/O devices of an I/O island are electrically connected.
Direct island bus integration (PXC3...)	Desigo TRA: the PXC3... room automation station and the I/O island are electrically connected (AC 24 V GND is connected to island bus GND).
Direct island bus integration (PXC100..., PXC200...)	Desigo: the PXC...D automation station and the I/O island are electrically isolated. The island bus driver of the automation station is supplied by the I/O island.
Integration via P-Bus BIM	P-bus and island bus are electrically connected (G0 and ⊥).
Integration via PROFINET BIM	Island bus and PROFINET BIM are electrically connected. The BIM is electrically isolated from the PROFINET (Ethernet bus) and all the devices connected to it (PCs, S7).
Island bus expansion	Island bus and island bus expansion are electrically isolated (via a PTC protective resistor)

#### Protection against incorrect wiring of AC/DC 24 V



- All low-voltage terminals of all TX-I/O products are interchangeable and may be short-circuited against system neutral without damaging the electronic circuitry.
- However, the error should be fixed as soon as possible.
- **There is no protection against incorrectly wired external voltages from the field devices (e.g. AC 230 V).**

## I/O modules

The following regulations apply to the I/O modules:

Item	Regulations
Combination of mains and low voltage is admissible	With <b>relay modules</b> the safe distance of PCB tracks and terminals is wide enough to make the combination of mains and low voltage on the same module permissible.
Status contacts	<ul style="list-style-type: none"><li>• Digital inputs are not electrically isolated from the system electronics.<ul style="list-style-type: none"><li>– Mechanical contacts must be volt-free.</li><li>– Electronic switches must comply with SELV or PELV standards.</li></ul></li><li>• Voltage sensing is not supported.</li></ul>
Override buttons	 The override buttons on the switching and positioning outputs must <b>not</b> be used as safety isolators, e.g. for service or maintenance purposes.

### 2.4.3 Connecting field devices to I/O modules

#### Devices with different voltage circuits

The voltage circuits of these devices must be **adequately isolated** from each other so that they can be connected directly and without additional insulation (see the principles diagram below).

#### Interfaces between different voltage circuits

Connections via interfaces may result in the distribution of dangerous voltages throughout the building. Always ensure in such cases that the required insulation is provided and that you have observed all the relevant installation regulations.

#### SELV / PELV

The following applies to low-voltage field devices and interfaces:

Item	Regulations
Field devices connected to I/O modules	Field devices such as sensors, status contacts and actuators connected to the low-voltage inputs and outputs of I/O modules must comply with the requirements for SELV or PELV.
Low voltage interfaces	The interfaces of field devices and other systems must also satisfy SELV or PELV requirements.

**Principles diagram: Connection of the field devices to the I/O modules**

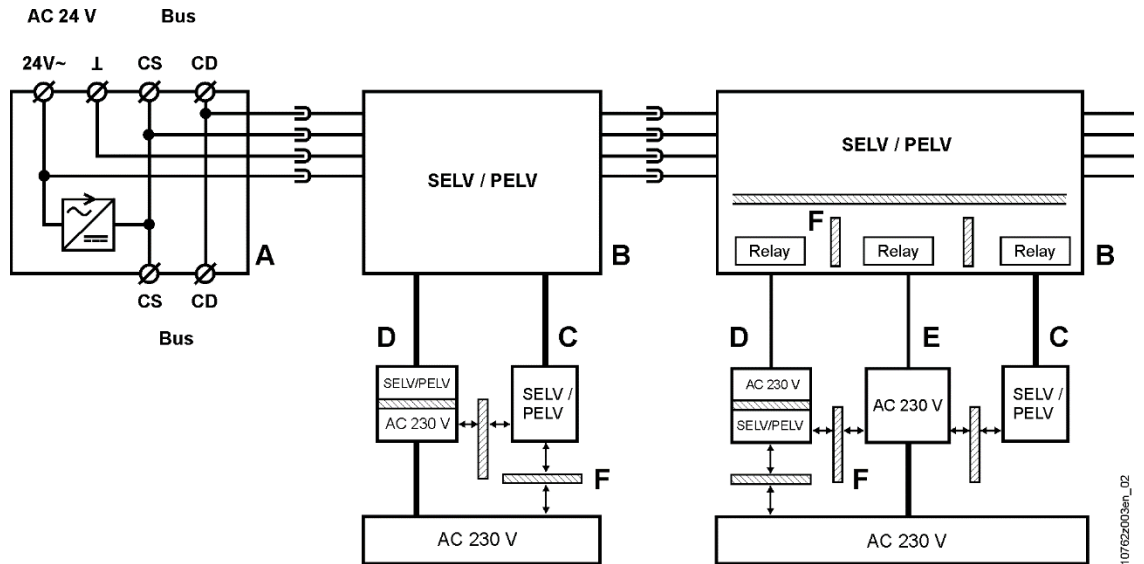

- Key
- A Power supply module
  - B I/O modules
  - C Field devices with SELV/PELV circuits only
  - D Field devices with mains voltage and SELV/PELV circuits
  - E Field devices with mains voltage circuits only
  - F **Double or reinforced insulation to EN 60 630, test voltage AC 3750 V**

**2.4.4 Connection of a PC (tool) to a P-bus BIM**

The USB interface of the P-Bus BIM incorporates a safety circuit to prevent the transfer of hazardous voltages to the PC. Earthing: see page 44.

At the same time, the PC is protected against incorrect voltages up to 24 V from the I/O island.

## 3 TX-I/O™ module system and accessories

### 3.1 The I/O modules in the control panel

#### Simple example (Design)

The diagram below is a schematic representation of the modules in the control panel, and shows how they are connected to the bus manager and to the relevant internal and external elements.

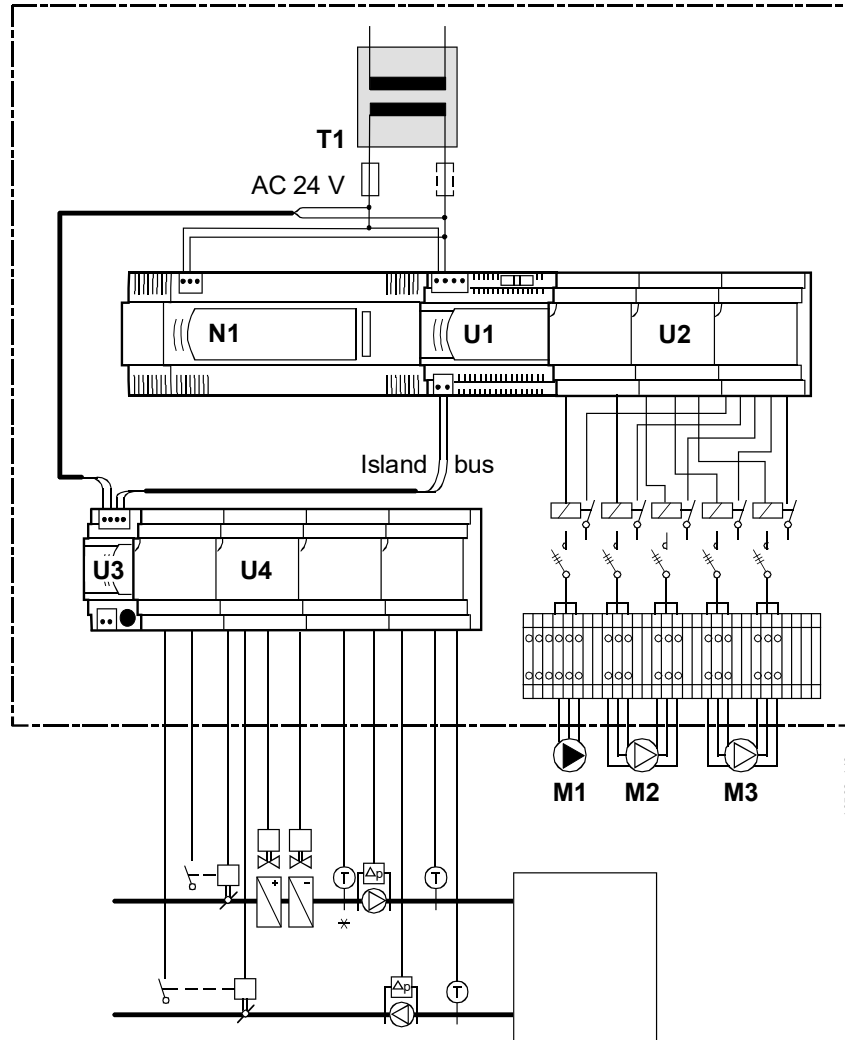

Key	T1	Transformer AC 230 V / AC 24 V
	N1	Automation station
	U1	Power supply module
	U2	I/O row with outgoing connections to devices located inside the control panel
	U3	Bus connection module
	U4	I/O row with connections to the external field devices
	M1	Heating coil pump
	M2, M3	Supply air fan, extract air fan

#### Role of the I/O modules

The I/O modules act as signal converters. They form the interface between the bus manager and the relevant devices in the building services plant.

The I/O module's terminal bases provide the connection terminals for wiring on the field device side; there is no need for separate terminal strips.

## 3.2 The TX-I/O™ module system

### Example: two I/O rows

The upper I/O row receives its power from a power supply module, the lower I/O row from a bus connection module.

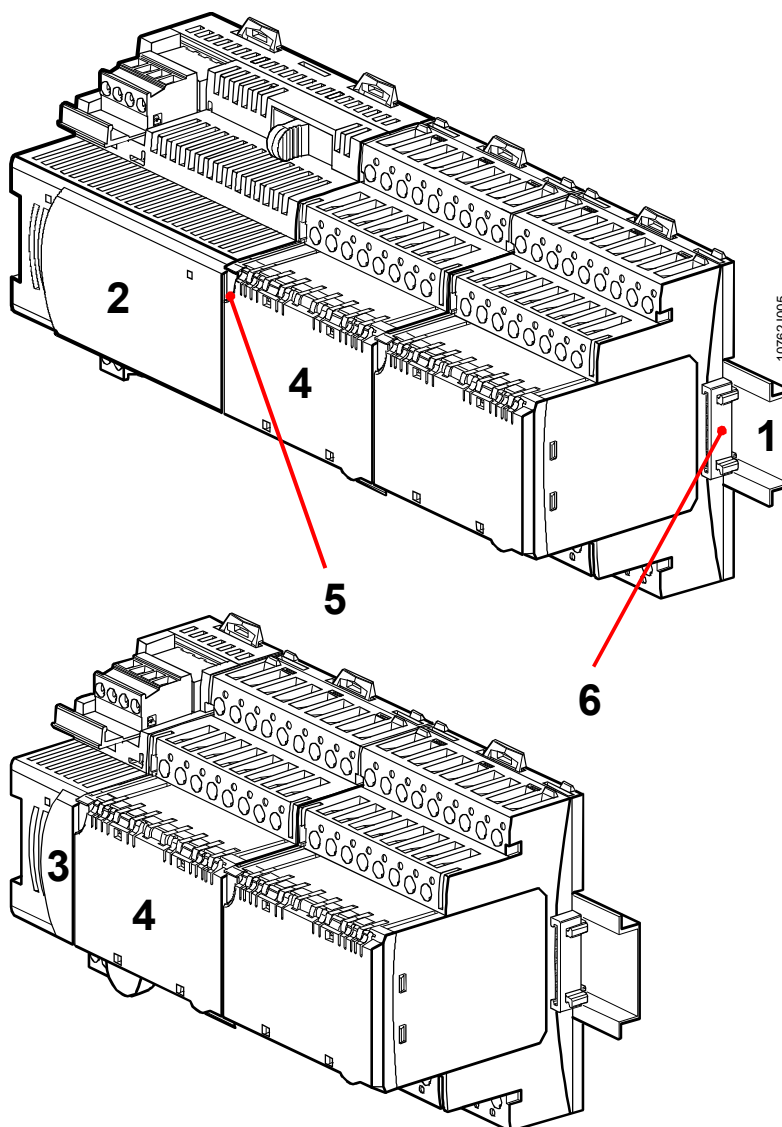

Components of the module system

- 1 Standard mounting-rail (accessory not supplied by Siemens)
- 2 Power supply module
- 3 Bus connection module
- 4 I/O module, TXM1...
- 5 Address key
- 6 Bus cover

### I/O module range

The I/O module range consists of multifunction modules with 6, 8 or 16 I/O points, which can be configured for all the basic functions of building automation and control. They convert the process values of the automation station into the signals required by the various plant components and vice versa.

## 3.3 The I/O modules

### 3.3.1 Construction

The following is an exploded diagram showing a single I/O module and accessories, and, to the right, a drawing of the complete module assembly, snap-mounted on a standard rail.

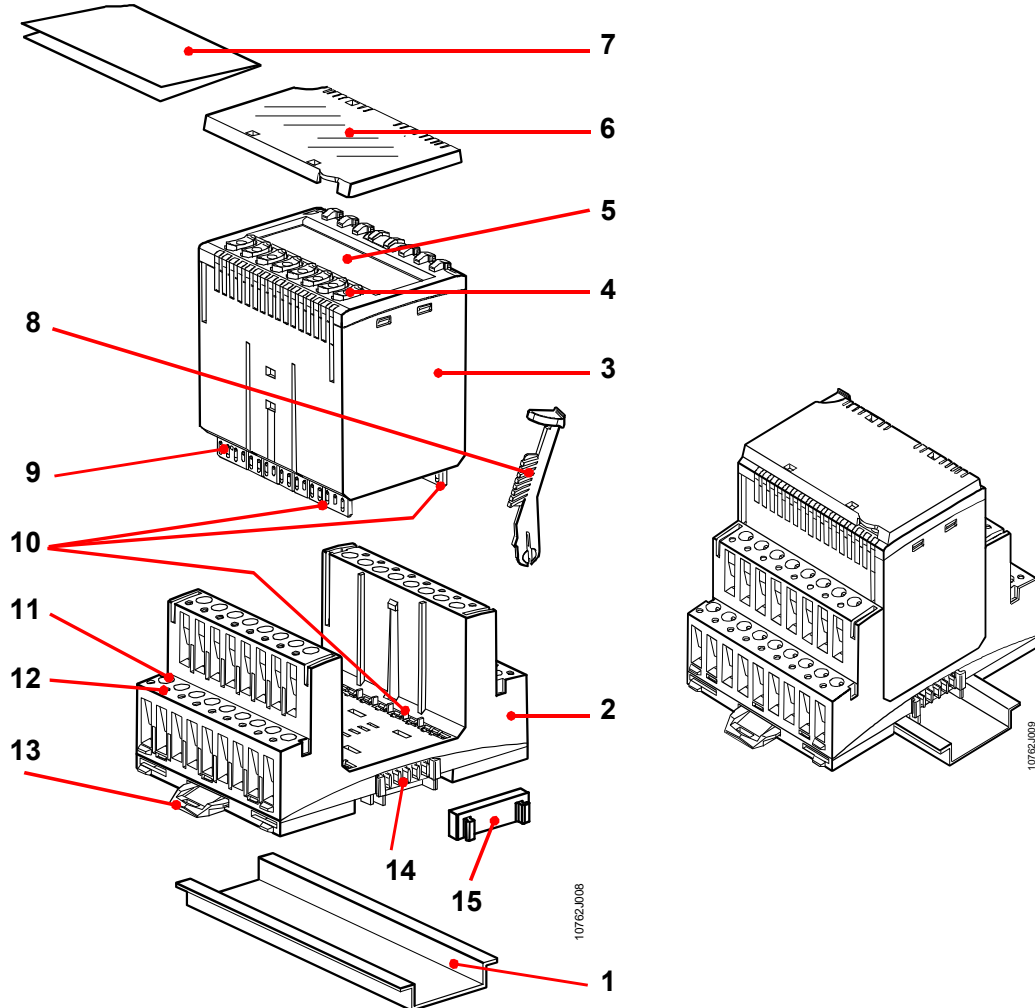

- |     |    |  |
|-----|----|--|
| Key | 1  | Standard mounting rail   |
|     | 2  | Terminal base (plug-in base for the I/O module)                              |
|     | 3  | Plug-in module (the actual functioning component of the I/O module assembly) |
|     | 4  | Local override facility (not applicable to all types)                        |
|     | 5  | LCD display (not applicable to all types)                                    |
|     | 6  | Detachable label holder  |
|     | 7  | Label  |
|     | 8  | Address key with mechanically encoded module address                         |
|     | 9  | Plug-in contacts between the terminal base and the plug-in module            |
|     | 10 | Mechanical coding between terminal base and plug-in module                   |
|     | 11 | Terminal screws  |
|     | 12 | Test pickups (test points)   |
|     | 13 | Slide fitting to lock assembly into position on standard mounting rail       |
|     | 14 | Bus connector  |
|     | 15 | Bus connector cover  |

*Note: From Sept 2010, the module housings and the label holders have a new shape for stronger hold.*

## Suitable standard mounting rails

The following standard mounting rails can be used with the I/O module system:

- Top hat rails TH35-7.5 to EN60715 (35 x 7.5 mm)
- Other top hat rails that meet the following requirements:
  - Material thickness on the edge max. 1 mm thick, min. 3 mm wide
  - Inner opening min. 25 mm

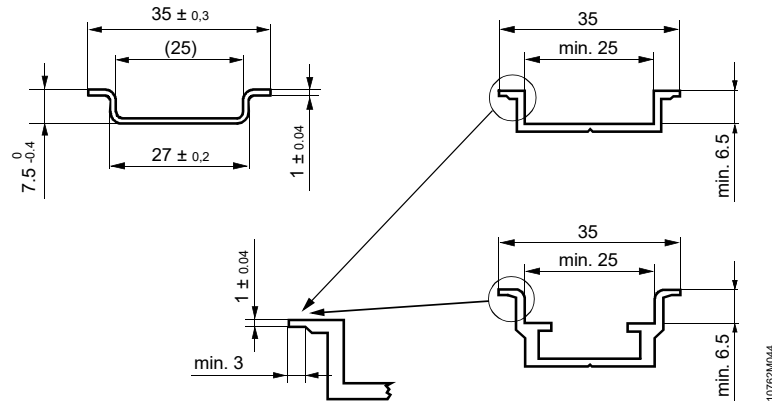

### 3.3.2 Mechanical features

The main mechanical features of the I/O modules:

- The modules are snap-mounted on standard mounting rails.
- The devices consist of a terminal base and the plug-in module.
- The separation of terminal base and plug-in module allows for quick replacement of the plug-in I/O module for service purposes.
- The plug-in module can be completely removed from the terminal base or moved into a "parked" position.
- In the parked position, the plug-in module is electrically isolated from the terminal base (field devices and bus communication).
  - The connected field devices can be measured via the test pickups without being affected by the electronics in the plug-in module (terminal isolation function).
  - The self-forming communication and power bus remains intact and available to the other modules.
- The connection terminals in the terminal base perform the function normally provided by the control panel terminal strips.
- The terminal base is mechanically coded. Plug-in modules with and without local override and display facilities are electrically compatible and can be plugged into the same terminal base.

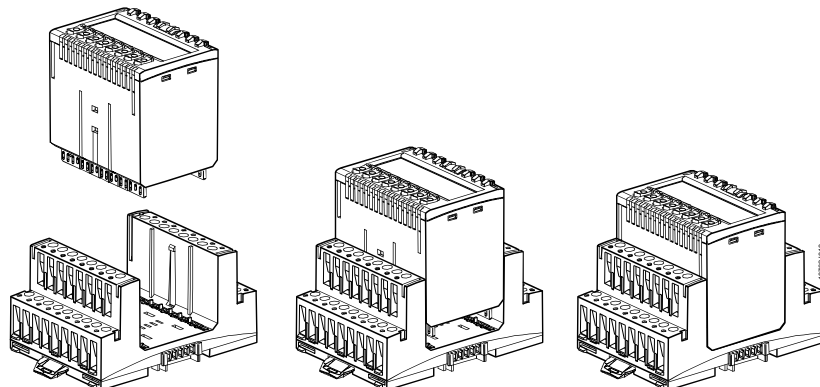

"Parked" position (disconnected from connection terminals)

Normal operation

### 3.3.3 Electrical characteristics

---

- Please also note the safety guidelines in Section 2
- For detailed electrical data, please refer to the module data sheets
- The following points are of particular note:

#### **Bus connectors**

The bus cables are described below in Section 3.4 "TXS1.12F10 power supply module and TXS1.EF10 bus connection module".

#### **Removing and inserting plug-in modules without disconnecting the supply**

The modules can be removed from or plugged into the terminal base without switching off the power (but not suitable for frequent action – risk of burnt contacts between the terminal base and the plug-in module, if large loads are connected to the terminals).

#### **Electrical isolation**

See "Wiring safety notes", page 17.

#### **Protection against incorrect wiring**

See "Wiring safety notes", page 17.

#### **Digital inputs**

- The modules support volt-free contacts or electronic switches such as transistors and optocouplers.  
Both N/O and N/C logic is supported.
- The interrogation voltage is derived from the module
- Voltage sensing is not supported.

#### **Signal neutral terminals**

All signal neutral terminals are interconnected, not in the terminal base but in the plug-in module. Hence, when the plug-in module is removed from the base, there is no connection.

#### **Relay contacts**

For applications involving frequent switching operations, it is important to be aware of the service life of the relay contacts. Please refer to the technical data in the data sheets or on page 117.

### 3.3.4 Indicators and operator controls

---

See Section 9 "Display, operation, and diagnostics".

### 3.4 TXS1.12F10 power supply module and TXS1.EF10 bus connection module

For details see data sheet N8183, [3].

Note The following information is also applicable to the power supply function of the TXB1.PBUS P-Bus interface module (BIM), see data sheet N8180, [5].

#### 3.4.1 Construction of the devices

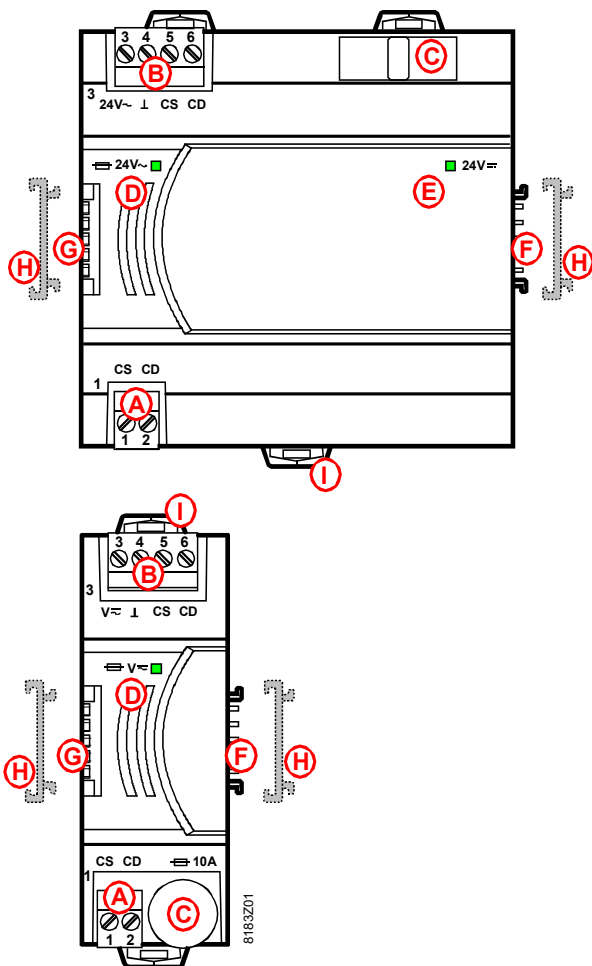

#### Key

- A Plug-in screw terminal ("1")
  - 1 CS DC 24 V supply for modules and field devices
  - 2 CD Island bus signal
- B Plug-in screw terminal ("3")
  - 3 24V~ Supply for the supply module and for field devices (TXS1.12F10)
  - 4 ⊥ Field device supply (TXS1.EF10)
  - 5 CS System neutral
  - 6 CD DC 24 V supply for modules and field devices
  - 6 CD Island bus signal
- C Fuse, M 10A for field supply
- D LED: "Field supply OK"
- E LED "DC 24 V module supply OK"
- F Bus connector (right) (with field device supply)
- G Bus connector (left) (no field device supply)
- H Bus connector cover
- I Slide fitting for standard mounting rail

### 3.4.2 Electrical characteristics

Please refer to the principles of electrical design, Section 10.

#### Circuit principles (TXS1.12F10 power supply module)

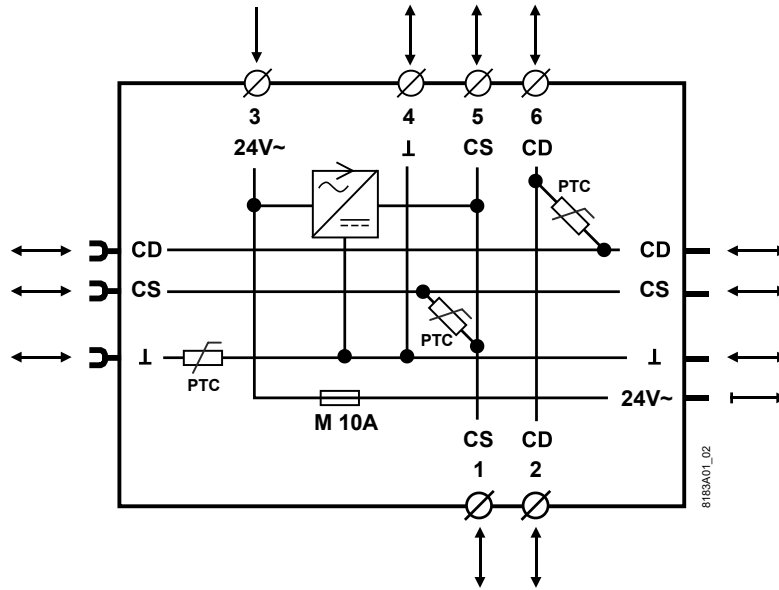

#### Note!

For AC 24 V, the bus is interrupted to the left, the supply module can only supply the modules to the right with 24V~V.

#### Circuit principles (TXS1.EF10 bus connection module)

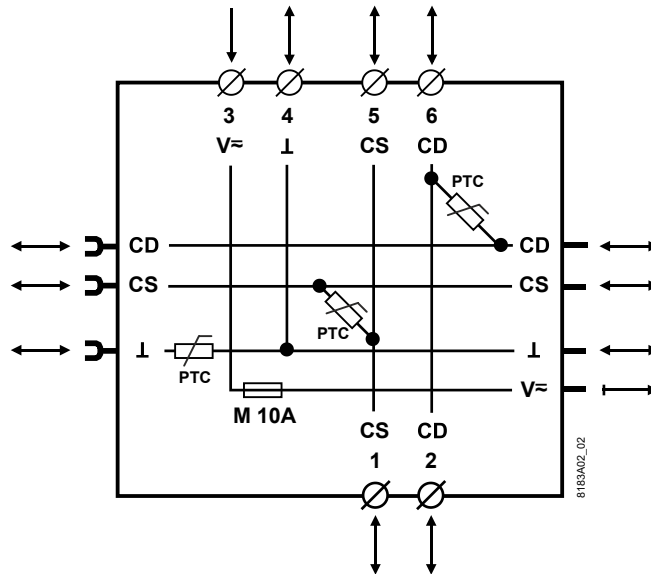

#### Note!

For V~, the bus is interrupted to the left, the bus connection module can only supply the modules to the right with V~.

### 3.4.3 Indicators and operator controls

See Section 9 "Display, operation, and diagnostics".

## 3.5 Island bus expansion module TXA1.IBE

See datasheet N8184 for more details [8]

### 3.5.1 Design

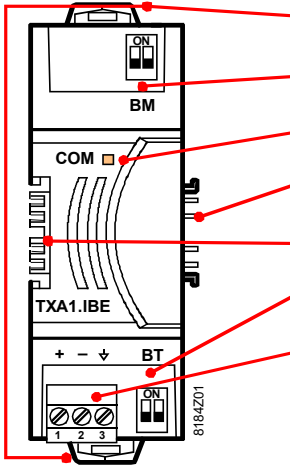

Attachment slide for standard rails

BM DIP switch for bus manager (island bus, setting instructions see page 95))

LED "COM", displays island bus communication

Bus connector right

Bus connector left

BT DIP switch for bus termination (island bus expansion, setting instructions page 95)

Plug-in screw terminals

+ Signal island bus expansion

- Signal island bus expansion

⇩ potential equalization

### 3.5.2 Electrical properties

See Section 10.6, "Island bus expansion ".

Schematic

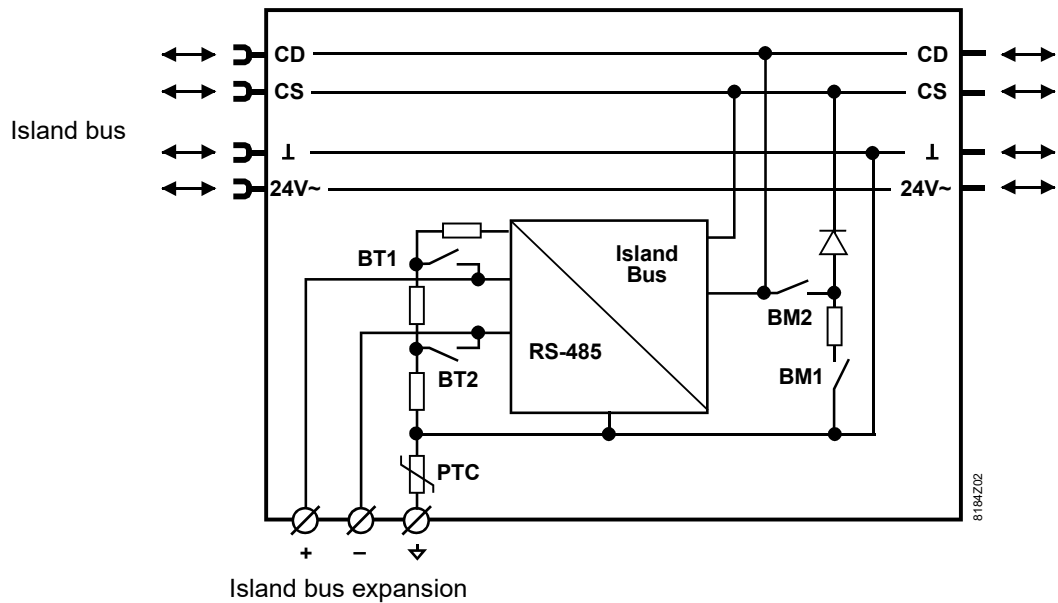

## 3.6 Accessories

### 3.6.1 Bus covers

- The purpose of the bus covers is as follows:
  - to close an I/O row mechanically
  - to prevent accidental physical contact with the bus contacts.
- The covers are suitable for both the left and right end of the TX-I/O devices.
- Each power supply module and bus connection module comes with 3 bus covers (includes 1 spare).

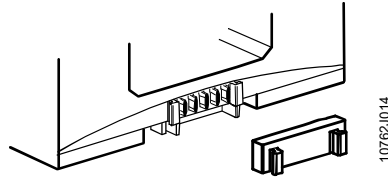

### 3.6.2 Address key

#### Address key

- The module address is mechanically encoded in the address key.
- Based on the address, the module receives information via the bus indicating which field devices are connected to this module, and which function is required for the field devices.

For details see page 35.

#### Reset key

Serves to set the module function back to the factory state (default function on each of the I/O points):

- The reset key is inserted in place of the address key and then swiveled out again. The module indicates the reset by briefly lighting all its I/O status LEDs.
- Note that a reset is only possible when the module is supplied with DC 24 V.

For details see page 58.

#### Distribution

Address keys are supplied in sets of 2 x 12, plus 2 reset keys.

The following sets are available:

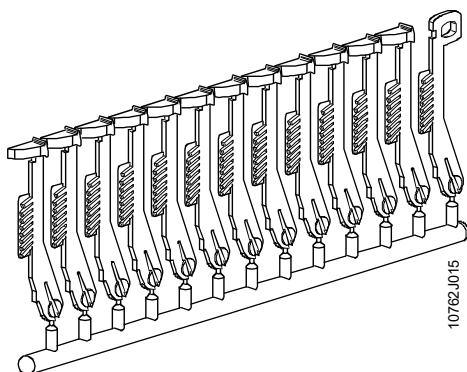

TXA1.K12	Address keys 1 ... 12	+ reset key
TXA1.K24	Address keys 1 ... 24	+ 2 reset keys
TXA1.K-48	Address keys 25 ... 48	+ 2 reset keys
TXA1.K-72	Address keys 49 ... 72	+ 2 reset keys
TXA1.K-96	Address keys 73 ... 96	+ 2 reset keys
TXA1.K-120	Address keys 97 ... 120	+ 2 reset keys
TXA1.5K120	Address keys 5, 10, 15 ... 120	+ 2 reset keys

### 3.6.3 Module labeling

- The plug-in module has a removable transparent cover (the label holder) for insertion of a label. The label can be used to describe the function of each I/O point.
- Pre-perforated A4 sheets of labels can be ordered under ASN TXA1.LA4.
- Designo: The labeling is carried out on a plant-specific basis, using the Siemens Smart Infrastructure engineering system.  
Labels can also be created and printed by the control panel builder with the aid of the BIM Tool.
- Simatic: The labeling is done using Excel templates.

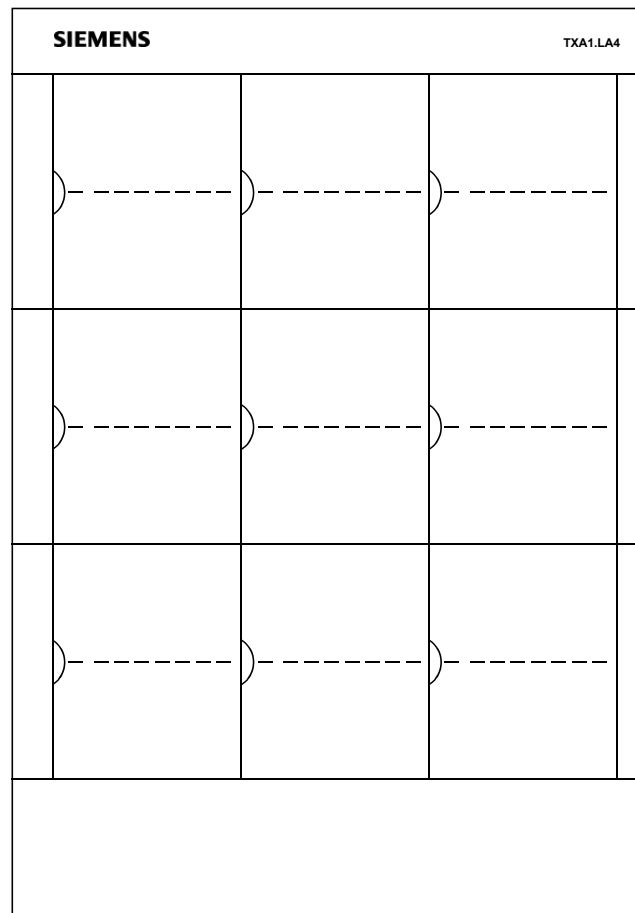

# 4 TX-I/O™ mounting instructions

## 4.1 Before you start

---

### Relevant documents

The following documents must be taken into account when installing equipment in the control panel:

1. *This engineering and installation guide*  
It contains general rules and instructions for the mounting and layout of the I/O modules and other equipment in the control panel.
2. *All project-specific documentation*
  - a list of all modules and their addresses
  - electrical wiring diagrams
  - a drawing of the layout of equipment in the control panel.

### Check list:

#### Essential information

The table below lists the information relevant for control panel installation. Make sure that you can find this information in the project-specific documentation.

Item	Does the documentation contain the required answers?	OK
Cable routing	Where do the cables to and from the field devices enter the control panel? From the top? From the bottom? Or from top and bottom?	
Orientation of I/O modules	How are the I/O modules mounted: Horizontally, vertically, overhead, etc.	
Grouping on I/O rows	Are the modules on the I/O rows grouped as follows: <ul style="list-style-type: none"><li>• I/O modules to be wired internally to control-panel equipment?</li><li>• I/O modules to be connected via external cables to the field devices (i.e. also serving as terminal strips)?</li></ul>	
Order of I/O modules	Does the wiring diagram or a list of modules show the order in which to connect the I/O modules?	

## 4.2 Structure or an I/O island

---

An I/O island is composed of the I/O modules and of the following elements:

- **Desigo TRA:** For each I/O island **ONE automation station**.
- **Island bus integration:** For each I/O island **ONE automation station** and a power supply module.
- **Integration via P-Bus BIM:** For each I/O island **ONE bus interface module (BIM)** with integrated power supply.
- **Integration via PROFINET BIM:**  
For each I/O island **ONE bus interface module (BIM)** plus a power supply module or a bus connection module with an external DC 24 V supply.
- Each **new I/O row** begins with a bus connection module or a power supply module.
- If the **DC 24 V supply** (max. 1.2 A) is "used up", an additional **power supply module** is needed.
- If the **AC 24 V field supply** (max. 6 A) is "used up", a **bus connection module** is needed.
- If a **separate fuse** or a **field supply with a voltage other than AC 24 V** is required (max. 6 A), a **bus connection module** is needed.

For details, please note the information and instructions concerning control panels in Section 5.2, "Physical layout", the wiring examples in Section 6.4.2, as well as the criteria for the deployment of supply modules and bus connection modules in the principles of electric design, Section 9.7.

## 4.3 Structure of the I/O rows

---

The I/O modules are connected to the following devices to create I/O rows:

- |  |    |
|--|----|
| • Room automation station with island bus connectors | AS |
| • Automation station with island bus connectors      | AS |
| • Bus interface module (BIM)                         | A  |
| • TXS1.12F10 power supply module                     | A  |
| • TXS1.EF10 bus connection module                    | A  |
| • TXA1.IBE island bus expansion module (optional)    | B  |
| • I/O modules  | C  |

The first item(s) on each I/O row must be either one or two devices from category "AS" or "A" to provide the bus signal, the module supply voltage and the field device supply.

These are then followed by "C", the I/O modules.

Other bus connection modules and a maximum of one more power supply module per I/O row may be connected between the I/O modules.

An island bus expansion module can be placed anywhere in the I/O row. For signal quality reasons, however, the best place is directly after device "AS" or "A".

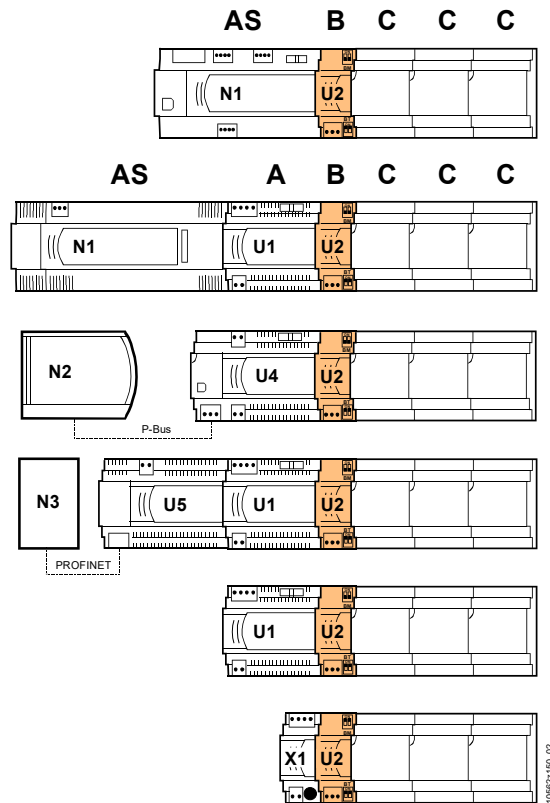

Key

- N1 Room automation station or Automation station with island bus
- N2 Automation station with P-bus
- N3 Simatic S7 300 / 400
- U4 P-Bus-BIM (Bus interface module) with built-in supply
- U5 PROFINET BIM
- U1 TXS1.12F10 power supply module
- U2 TXA1.IBE Island bus expansion module (optional)
- X1 TXS1.EF10 bus connection modules

Each I/O row is connected from left to right (or from top to bottom) by mounting the devices vertically one after the other on the standard mounting rail.

The island bus is created automatically in this process.

- The first item mounted on each I/O row must be the device or devices that deliver the bus signal, the module power supply and the field device supply (e.g. a power supply module)
  - Pull the slide-fitting outwards (1)
  - Press the device onto the rail (2)
  - Push the slide-fitting back into place (3)
- The I/O module assemblies can then be plugged in one after the other (4), (5).

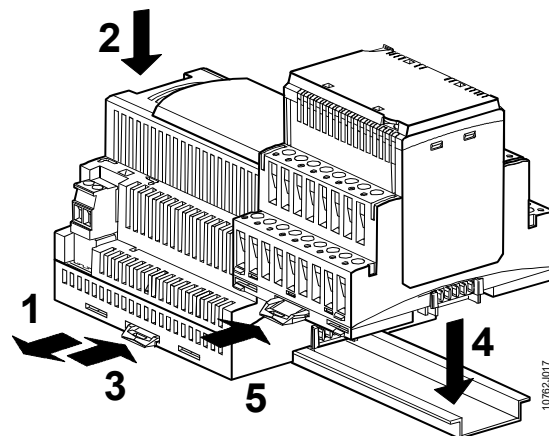

## 4.4 Replacing a module

### Plug-in module

A **plug-in module** can be replaced at any time by the same or a compatible type, even while the system is running.

### Module assembly

When replacing a complete **I/O module assembly**, please note the following:

- The bus connector extends from the right-hand side of all TX-I/O devices. For this reason, the adjacent plug-in module to the right must be unplugged from its terminal base.
- Removing the terminal base interrupts the island bus, so that modules to the right are no longer supplied.

Procedure for replacing module  $U_n$  where "n" is the module number:

- FIRST swivel the address key outward on the adjacent plug-in module  $U_{n+1}$  (1)
- Unplug module  $U_{n+1}$  from its terminal base (2)
- Pull the slide fittings outward on the terminal base for  $U_n$  (3)
- Remove the complete module assembly  $U_n$  (including terminal base) (4)
- Insert the new plug-in module assembly  $U_n$  without address key
- Push the slide fittings on the terminal base  $U_n$  inward
- Move the address key from the old module to the new one and swivel it carefully into position
- Plug the adjacent plug-in module  $U_{n+1}$  back into its terminal base, and swivel the address key carefully back into position.

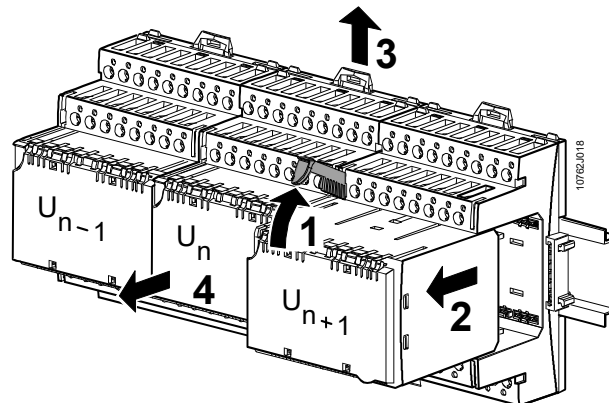

As soon as the new module starts communicating with the bus manager, it will be configured according to the module address and start operation shortly after.



### Note!

**Reset previously used plug-in module**

If you insert a previously used plug-in module or module assembly, **it must be reset to factory settings** before swiveling the address key in (**use the reset key**).

**Bus interface modules, power supply modules, bus connection modules**

- The same procedure as for an I/O module is required
- These devices have plug-in terminals for easy connection.

## 4.5 Replacing a bus interface module

---

### P-Bus BIM

If you replace a P-Bus BIM, it is mandatory that **the new BIM contains no old IOMD**. Otherwise the connected I/O modules are re-configured immediately after powering the BIM with AC 24 V or after connecting the I/O modules to the BIM.

In order to fully reset a P-bus BIM, the following steps are required:

1. Disconnect the PXC from the power supply
2. Disconnect the BIM from the power supply
3. On the BIM, place a shunt between conductors CD and CS to create a short circuit
4. Power the BIM with AC 24 V (no danger for the BIM by the short circuit)
5. Download the correct configuration
6. Remove the short circuit
7. Power the PXC with AC 24 V

Now the TX-I/O modules will keep their original configuration and the BIM will start working.

### PROFINET BIM

1. Before inserting, assign the correct IP address and the correct device name to the PROFINET BIM , using S7 HW Config.  
To do this, connect the tool via Ethernet, and supply the BIM with AC 24 V.  
You might also parameterize the IP addresses and the device name after the exchange. BUT this involves the risk of duplicate addresses with the preset address (192.168.1.1) and the preset device name (profinetbim).
2. After parameterizing, disconnect the BIM from the power supply for a short time.
3. Replace the BIM. The new BIM will be automatically loaded by the S7 300 / 400.
4. The S7 and the TX-I/O modules can continue to operate during the exchange, no need to switch them off.

**Note** The PROFINET BIM does not locally store configuration information of the connected TX-I/O modules.

## 4.6 Labeling and addressing the modules

### 4.6.1 Procedure and label allocation

---

#### Different procedures

Depending on the running of the project, and on how the flow of products is organized, the labels are

- either supplied with the devices to be installed,
- or inserted at the commissioning phase on the site where the plant is located

### 4.6.2 Labeling the I/O modules

---

#### Location of labels

In order to identify each I/O module and its connections unambiguously, information is provided in the following places:

- On the front of the module
  - Module type, and symbols for indicators and override options
  - Insertable label, for user-definable information
- Address key
  - Address numbers from 1 ... 120

#### Labels

The content of the insertable labels for the I/O modules can be freely defined. In the case of plant engineered with DTS or XWORKS, the labels are created using the engineering tools. The label forms are printed automatically in accordance with the module configuration.

Labels generated in this way are printed with the module address and the function of each I/O point.

#### Connection terminals

The connection terminals are identified only in general terms, as the I/O points can have various functions.

#### Inserting the labels

- The I/O module has a detachable transparent cover (the label holder) for insertion of the label.
- The modules can be operated with or without this "cover".
- Note: From Sept 2010, the module housings and the label holders have a new shape for stronger hold.

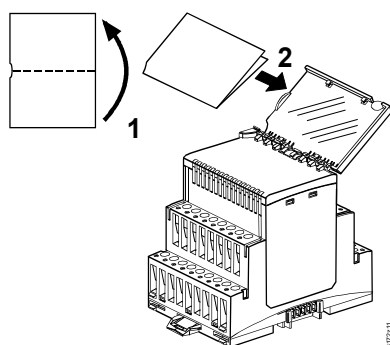

Removing

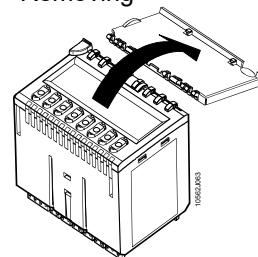

Mounting

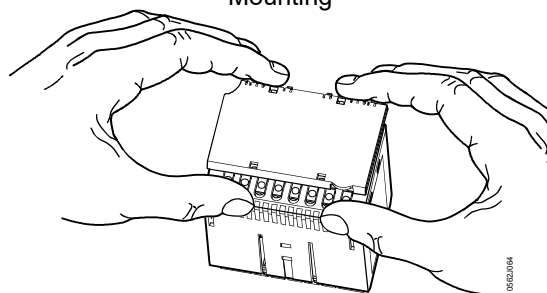

### 4.6.3 Addressing

- To enable the bus manager to identify and communicate with a given I/O module, each I/O module requires its own address.
- Without address key the module is in a secure, inactive state
- With the address key inserted the module has its full functionality
- The module address is mechanically encoded in the address key. This is plugged into the terminal base and swiveled into position in the I/O module.
- Based on the address, the module is configured by the bus manager via the island bus, and receives information indicating which field devices are connected, and which function is required for the field devices.
- When replacing the plug-in I/O module, the address key must FIRST be swiveled outward. This causes the load to be switched off. The values remain saved in the bus manager. The key remains plugged into the terminal base so that the bus manager can communicate the required function to the new plug-in I/O module. Please note the warning in Section 4.4, "Replacing a module".



#### Caution!

The address key must be inserted firmly into the terminal base before swiveling it carefully into the plug-in module.

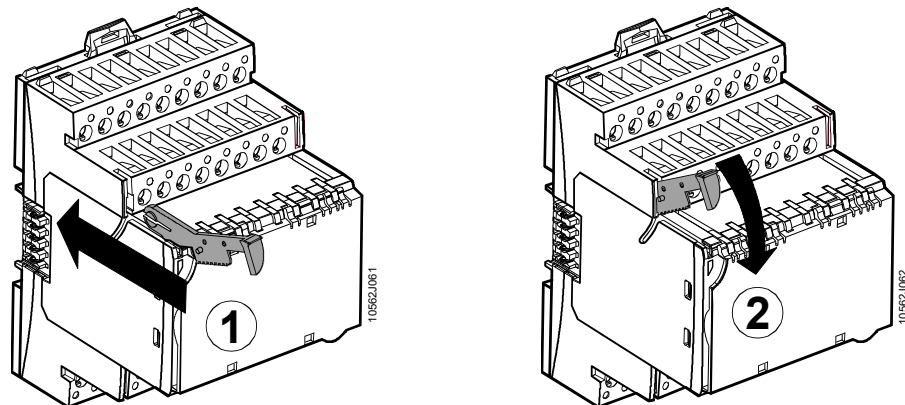

# 5 Control panel

## 5.1 Control panel requirements

### Requirements

The table below contains information on the general control-panel requirements. Please use this table to check compliance with these requirements.

Item	Requirements	OK
Mechanical design	Check that the construction, stability and insulation of the control panel meet the regulations applicable to the location concerned.	
Ambient conditions	<ul style="list-style-type: none"><li>The TX-I/O range is designed for an ambient temperature of 0 to 50 °C. It is important to ensure sufficient ventilation in the control panel to maintain the admissible ambient temperatures applicable to all the equipment.</li><li>Check for compliance with the permitted values for the devices, as specified under "Technical data" in the data sheets, in relation to<ul style="list-style-type: none"><li>humidity, vibration</li><li>device protection class and protection standard</li></ul></li></ul> <p><b>Important: These regulations apply to the site where the plant is located!</b></p>	
EMC compliant control panel	The control panel must comply with the regulations described in Section 5.3.	

### Mechanical dimensions

The following information is used to determine the required control panel dimensions:

- the information on control panel layout options given in this section
- the dimension diagrams for the devices themselves, in the data sheets [2], [3], [5].

## 5.2 Physical layout

### 5.2.1 Orientation

The TX-I/O devices can be installed in any orientation:

Recommended	Also permitted
<ul style="list-style-type: none"><li>Wall-mounted, horizontally from left to right or from right to left</li><li>Wall-mounted, vertically from top to bottom or from bottom to top</li></ul>	<ul style="list-style-type: none"><li>Overhead</li><li>On any horizontal surface</li></ul>
<b>Ambient temperature -5...50 °C</b>	<b>Ambient temperature -5...50 °C</b>

Note Please provide sufficient ventilation to prevent inadmissible ambient temperatures.

**Restrictions for PXC3:** see data sheet N9203

## 5.2.2 Grouping and order of modules

---

Criteria for the order of the I/O modules and the division into groups:

- **Internal / external**
  - Outputs inside the control panel  
e.g. connections to starters for motor control
  - Outputs outside the control panel  
e.g. direct wiring to field devices such as sensors, transmitters, control equipment etc.
- Arranged in ascending order of **module address**.
- Grouped by DI, AI, AO, DO
- One "aggregate" (functional unit) after another
- Order based on **voltage type**:
  - AC 230 V mains voltage
  - Low voltage AC 24 V
- **Plant-specific** order:  
e.g. based on the functions of the individual control loops (I/O modules for sensors, transmitters and control equipment, control loop by control loop)

Other possible layout criteria:

- Country-specific regulations
- In-house conventions

## 5.2.3 Space requirements

---

### Hardware list

The space required in the control panel can be calculated as follows:

- Number of I/O modules x 63 mm
- Bus interface module: 1 x 128 mm per I/O island
- Number of power supply modules x 96 mm
- Number of bus connection modules x 32 mm
- Automation stations
- Transformers
- Terminal strips

### Observe clearance requirements!

Free access to connection terminals is required for connection and inspection. We recommend at least 30 mm clearance between the module and the trunking. This results in the following distance between standard mounting rails/trunking: 90 mm (module width) + (b = width of trunking) + 2 x ≥30 mm (space for wiring)

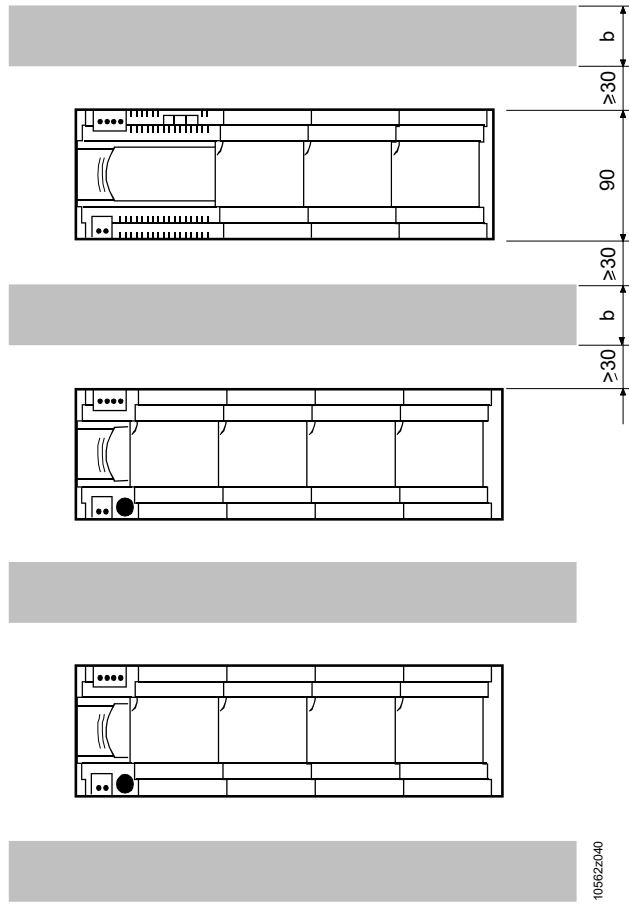

## 5.3 EMC compliant control panel

---

Please refer also to Section 6.7, "EMC compliant wiring".

### Introduction

One of the purposes of the control panel is to reduce electromagnetic interference. This depends on the **internal** and **external** electromagnetic interference (EMI) affecting the control panel.

For example, an AC inverter in the same control panel may represent an internal source of interference, while external interference may be caused by a radio transmitter in the near vicinity.

Control panels act as the reference point (earth) for cable screens and housings. They must be capable of isolating interference and short-circuiting interference voltages.

### General rules

For an EMC compliant control panel, the following general rules must be observed:

#### Mechanical design of control panel

- Internal walls should not be painted in the case of difficult EMC conditions
- Grids and rails must be conductive and must not be painted
- Screws must be fixed directly to the bare (conductive) surfaces of the control panel
- Copper straps must be used for connecting the earth mass to control-panel doors (possibly with an additional connection to the normal protective earth).

#### Layout of equipment in control panel

When designing the control panel, equipment emitting high levels of interference must be isolated from equipment susceptible to interference. Special attention must be paid to the connections between these two categories of equipment.

- Install high-level sources of interference and interference-susceptible devices in separate control panels
- Locate high-level interference sources outside the control panel. Ensure that no safety requirements are infringed in this process.
- Separate the groups of equipment within the control panel by use of partitions.

#### Screening

- Cable screens must be bonded to the metal structure of the control panel where they enter the control panel, and to the equipotential bonding system of the building.
- Screen terminals must be used for this purpose, and suitable connection points must be provided in the control panel (see illustration on page 52).

### Exception

Use of the screen for module supply, see section 10.5, page 82.

# 6 Wiring

## 6.1 Before you start

---



Before you start work on the wiring, please refer to Section 2, "Safety guidelines".

More information is also available in Section 3.3.3, "Electrical characteristics of the TX-I/O modules".

- Notes
- It is possible to start by mounting only the terminal bases.
  - However, the module assemblies can also be mounted as complete units (terminal base and plug-in module). The modules are inactive until the module power supply is connected to the bus. However, they can be damaged by incorrect wiring to the AC 230 V mains voltage.
  - In the "parked" position (see page 23) the plug-in modules are fully isolated from the terminal bases. The connected field devices can be measured via the test pickups without being affected by the plug-in module electronics (terminal isolation function).
  - As soon as the module power supply is connected, the factory-set **default functions** become available for the wiring test (see page 55)
  - The disabling function should be configured to decommission any unused I/O points. This also prevents local override.

## 6.2 General notes

---

### Trunking

Route the device wiring in trunking in the usual way.

*Recommendation:* Select trunking cross-sections with approx. 30 % spare space.

### Mains and low voltage

The equipment wiring inside and outside the control panel can be routed in the same trunking as other mains conductors, e.g. together with the cables to starters or current valves.

### Cable materials

Use standard stranded cables and wires. The ends may be connected directly or reinforced with core end sleeves or cable end pins.

 **Important:** Low voltage conductors that are routed adjacent to mains voltage conductors must, in accordance with the regulations, have the same insulation rating as mains voltage conductors.

### Wire cross-section

Internal control cables normally have a wire cross-section of 1.5 mm<sup>2</sup>.

## 6.3 Screw terminals

### Mechanical design

The terminals used for the TX-I/O devices are rising-cage terminals. The wire is protected by a fixed contact plate between the wire end and the tip of the screw.

### Test pick-ups (test terminals)

The I/O module terminals have test pickups (test terminals) for a pin diameter of 1.8 ... 2 mm.

### Wire cross-section

The admissible cross sections vary according to the table below

	I/O modules	Power supply module, bus connection module
Mechanical design	Rising cage, built into terminal base	Rising cage, plug-in
Test pick-ups	Pin diameter 1.8 ... 2 mm	None
Solid conductors	1 x 0,5 mm <sup>2</sup> to 4mm <sup>2</sup> or 2 x 0,6 mmØ to 1,5 mm <sup>2</sup>	1 x 0,6 mmØ o 2,5mm <sup>2</sup> or 2 x 0,6 mmØ to 1,0 mm <sup>2</sup>
Stranded conductors without connector sleeves	1 x 0,5 mm <sup>2</sup> o 2,5 mm <sup>2</sup> or 2 x 0,6 mmØ to 1,5 mm <sup>2</sup>	1 x 0.6 mmØ o 2.5 mm <sup>2</sup> or 2 x 0,6 mmØ to 1,5 mm <sup>2</sup>
Stranded conductors with connector sleeves (DIN 46228/1)	1 x 0,6 mmØ o 2,5 mm <sup>2</sup> or 2 x 0,6 mmØ to 1,5 mm <sup>2</sup>	1 x 0,6 mmØ o 2,5mm <sup>2</sup> or 2 x 0,6 mmØ to 1,0 mm <sup>2</sup>



### Caution!

For the admissible wire cross sections, please note the sizing guidelines!

### Tightening torque

When using electric screwdrivers for wiring terminals always set the torque to **0.5...0.6 Nm or 50...60 Ncm**.

### Screwdrivers for I/O modules

The I/O module connection terminals have combined screws \*.

- No. 1 screwdriver for slotted or Pozidriv recessed-head \* screws)
- **Shaft diameter max. 4.5 mm** (otherwise the terminal base is damaged and the screws fall off)
- Min. shaft length 26mm, but ideally 40 mm (allows access to the screws while plug-in module is in the "parked" position).

Suitable bits with a long shaft are available, for example, from Weidmueller:

- Slotted screws: BIT C6.3 0.6x3.5x75 Order No. 9024760000.
- Recessed-head screws \* BIT E6,3 PZ1x70 Order No. 9024100000 (Pozidriv).

\* Combined slotted / recessed-head screws from mid-2012

## 6.4 Wiring of AC 24 V and bus

### Binding documents

The control panel wiring must be carried out in compliance with the project-specific electrical diagram.

### Basic layout

This example of a schematic diagram shows the basic connection of the power supply cables.

Note The wiring for the AC 230 V supply is not described specifically in this document.

### Wiring example (Design)

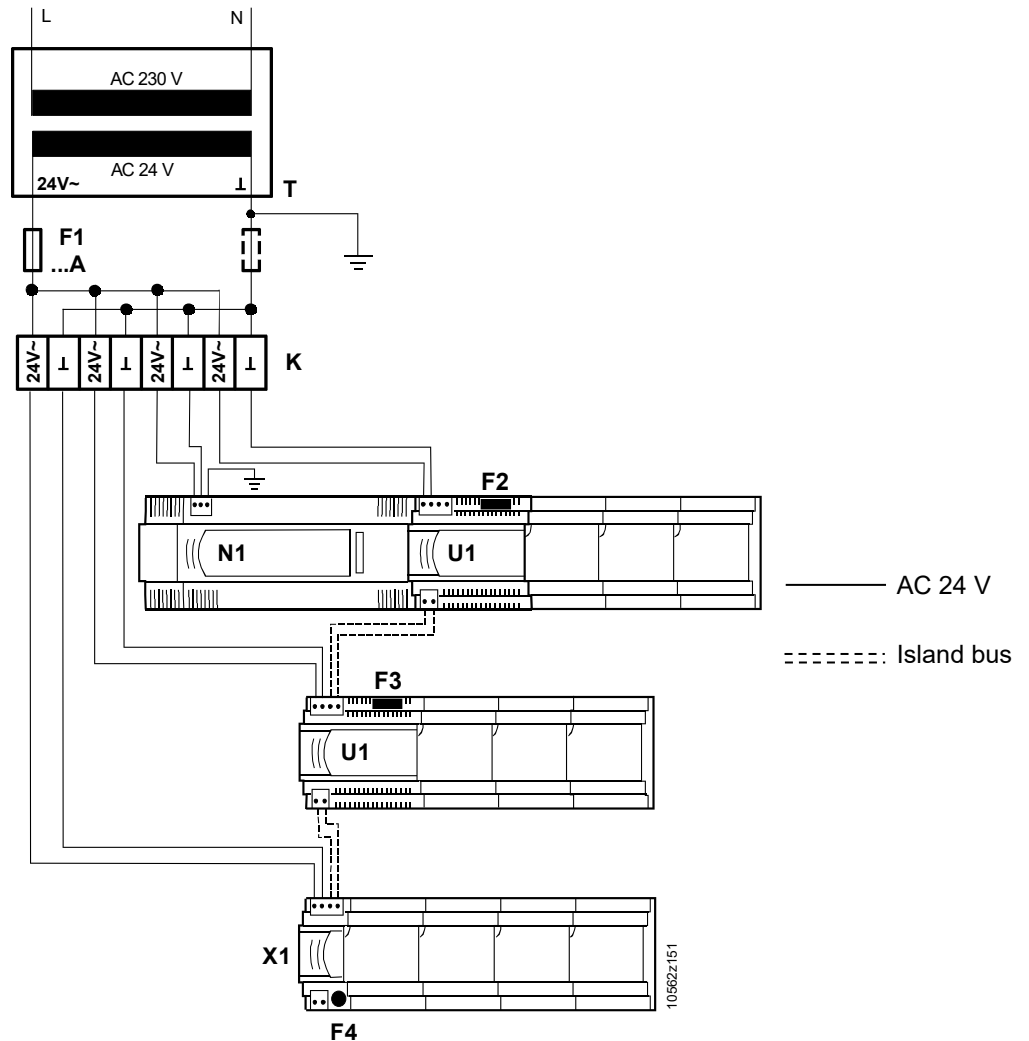

Key	T	Safety isolating transformer AC 230 V/AC 24 V to EN 61 558
	K	Terminal block for distribution of AC 24 V and $\perp$ in "star" configuration
	N1	Automation station
	U1	TXS1.12F10 power supply module
	X1	TXS1.EF10 bus connection modules
	F1	Low voltage fuse for max. power consumption with AC 24 V
	F2, F3	Fine-wire medium time lag fuse, 10 A, factory-fitted in bus interface module
	F4	Fine-wire medium time lag fuse, 10 A, factory-fitted in bus connection module

## 6.4.1 Wiring for AC 24 V

---

<b>Cable materials</b>	<p>The requirements for the 24 V~ and <math>\perp</math> conductors of the AC 24 V supply are as follows:</p> <ul style="list-style-type: none"><li>– Stranded or solid wire (copper)</li><li>– Singly or in two-core cable</li></ul>
<b>Maximum cable lengths</b>	<p>For details refer to Section 10.2.</p>
<b>Separate transformer for each I/O island</b>	<p>Recommendation: A separate transformer is recommended for each I/O island. However, if the devices are installed in the same control panel, then the bus managers and associated I/O rows may be supplied from the same transformer.</p>
<b>Separate supply cables for AC 24 V ("star" configuration)</b>	<p>Separate wiring to the bus manager and each I/O row from the connection terminal strip (<math>\perp</math>, 24V~) in order to keep voltage drop small. This terminal strip should be installed close to the transformer (see "Wiring examples").</p>
<b>Connecting <math>\perp</math> of separate systems</b>	<p>The system neutral conductors (<math>\perp</math>) of separate systems must not be interconnected. This is to prevent earth loops.</p> <p>Examples:</p> <ul style="list-style-type: none"><li>– 0 ... 10 V converters or current loops (do not earth the local supply transformers!)</li><li>– PCs (PCs are generally earthed → use a notebook PC for tools! )</li></ul>
<b>Separate power supply for bus managers and I/O islands and Earthing of <math>\perp</math></b>	<p>PELV systems must be connected to earth at one point only for each I/O island. Usually they are earthed at the transformer.</p> <p>A <b>PXC3... room automation station and the island bus</b> are electrically connected (<math>\perp</math>). Within one I/O island, it is permissible to supply power separately to the PXC3... and the associated I/O rows by use of one transformer each.</p> <p>However, the system neutral terminals (<math>\perp</math>) of the two transformers must be interconnected, because <math>\perp</math> is used as the common return.</p> <p>An <b>automation station with island bus connectors</b> and the I/O island are electrically isolated (the island driver of the automation station is supplied by the I/O island ).</p> <p>Separate supply of the automation station and the adjacent I/O row by separate transformers is admissible. System neutral (<math>\perp</math>) of the two transformers may be connected or isolated.</p> <p><b>P-bus and island bus</b> are electrically connected (G0 and <math>\perp</math>). Within one I/O island, it is permissible to supply power separately to the P-bus BIM and the associated I/O rows by use of one transformer each.</p> <p>However, the system neutral conductors (<math>\perp</math>) of the two transformers must be interconnected, because <math>\perp</math> is used as the common return.</p> <p><b>PROFINET and island bus</b> are electrically connected. Within one I/O island, it is permissible to supply power separately to the BIM and the associated I/O rows by use of one transformer each.</p> <p>However, the system neutral conductors (<math>\perp</math>) of the two transformers must be interconnected, because <math>\perp</math> is used as the common return.</p> <p><b>Island bus expansion:</b></p> <p>The island bus and island bus expansion are electrically isolated (via a PTC protective resistor).</p> <p>For most cases, it makes sense to separate power to local sub-island and remote sub-islands.</p>

You can also power the remote sub-island from the local sub-island when it requires very little electricity (does not power field devices).  
 System ground ( $\perp$ ) is connected in this case, since  $\perp$  serves as a common return.  
 If a sub-island is powered by its own transformer, it may be earthed separately. If it is not earthed, an equalization wire must be installed.  
 For earthing details and examples of the island bus expansion see section 10.6.6.

**Transformer phasing**

There is no need to take account of the relationship between the transformer phases. This means different phases (L1, L2, L3) can be used for the transformer supply.

**Separate power supply for each I/O row**

This may be necessary or advisable for

- Two I/O rows separated by a long distance
- High power-demand at the I/O modules (actuators)

## 6.4.2 Wiring for the island bus (module supply DC 24 V)

---

**Cable materials**

- The requirements for the CS and CD conductors (communication supply and communication data) of the island bus are as follows:
  - 2-core round cord without shield
  - Single cables are not admissible, either inside or outside the control panel.

- Notes
- Flat cord is admissible, but the EMC-immunity is lower than with round cord.
  - The island bus can be extended to a length of 100 m by using coaxial cable (see Section 10.5).

**Maximum cable lengths**

For details refer to Section 10.5.

**Routing of the bus cable**

- The bus cable **MUST** be routed together with the supply cable AC 24 V (see wiring examples in Section 6.5.2). Both are part of the bus connection.
- In principle, the bus connection **MAY** be routed together with AC 3 x 400 V conductors.  
 However, to maintain electromagnetic compatibility, we recommend that low voltage conductors be separated from mains conductors. Recommended minimum clearance: 150 mm.  
 Caution: Low voltage conductors that are routed adjacent to mains conductors must have the same insulation rating as the mains conductors.

**Bus topology**

- Serial wiring and a "star" configuration are admissible.  
 To this end, the relevant terminals on the power supply modules are available in duplicate and interconnected internally (see Section 3.4, "TXS1.12F10 power supply module and TXS1.EF10 bus connection module").
- **The bus must not be wired in a ring configuration.**

**Only ONE bus manager per I/O row**

- Never connect more than one bus manager via the same island bus.

*Definition: One I/O island = all modules that are connected to the same island bus segment, i.e. to the same bus manager.*

**Only one island bus connection per I/O row**

- The CD conductor may be connected once only for each I/O row. It is not permissible, when using two power supply modules, to connect two bus trunks to one I/O row (this would create a ring configuration!).

**System neutral ( $\perp$ )**

- The bus needs  $\perp$  in addition to the CS and CD conductors.
- This conductor is routed together with AC 24 V. See the examples below and the illustration in Section 6.4.

### 6.4.3 Wiring island bus expansion

---

**Wiring material**

See Section 10.6

**Maximum wire length**

See Section 10.6

**Cabling the bus cable**

- Low-voltage wiring and cabled next wiring mains voltage, must have the same isolation strength as is used for the mains voltage.
- We recommend separating low-voltage wiring from mains voltage for reasons of electro-magnetic compatibility. Recommended minimum distance: 150 mm.

**Bus topology**

- Line topology only is allowed

**ONE island bus expansion module only per sub-island**

- Cascading (more than one island bus expansion module per sub-island) is not permitted.

**System ground ( $\perp$ )**

- The island bus expansion operates without system ground ( $\perp$ ).
- The system ground ( $\perp$ ) must be connected when a remote sub-island is powered by the local sub-island. The  $\perp$  wire must be routed together with the cable for the island bus expansion.

# 6.5 Wiring examples









## 6.5.1 Principles

AC 24 V is always connected in a "star" configuration (from terminal block K)

For longer distances (typically between two control panels), the cables for bus and AC 24 V /  $\perp$  MUST be tied together.  
For shorter distances, also inside the control panel, we recommend this as well.

Note Admissible cable lengths see Sections 10.4 and 10.5.

### Key

T	Transformer	
K	Terminal block for the distribution of AC 24 V	
	Bus cable for CS and CD	
	Cable for AC 24 V and system neutral $\perp$	
	Cable $V\approx$ for field supply and system neutral $\perp$	
	Cable for system neutral $\perp$	
	Tie cables together *)	
	Automation station + power supply module P-BusBus interface module with built-in power supply PROFINET BIM plus power supply module	
		Supply module (TXS1.12F10)
		Bus connection module (TXS1.EF10)
	Row of I/O modules with island bus	

\*) Tie cables together to avoid loops (inductive disturbances),  
BUT do not route the  $\perp$  conductor in the same cable (capacitive disturbances).

### Internal circuit

The connections between the terminals and bus cables are as follows:

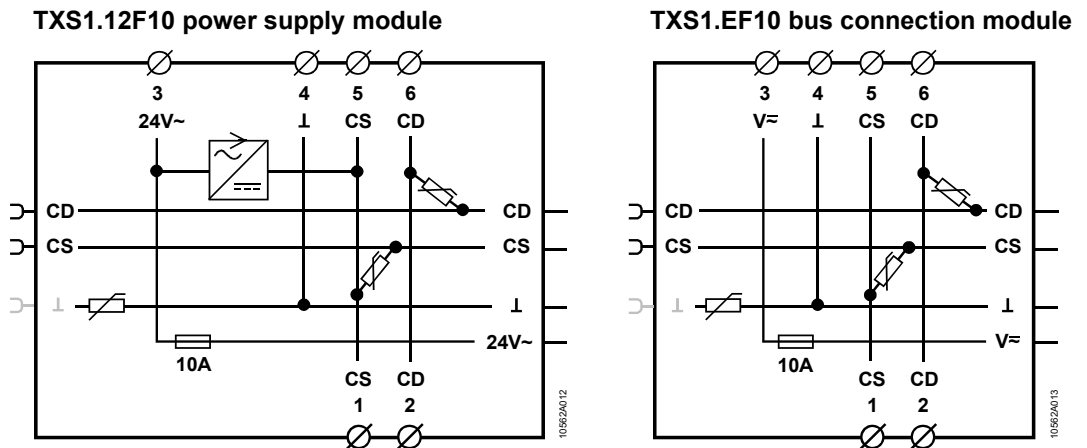

### 6.5.2 Example: 1 transformer, 1 or 2 control panels

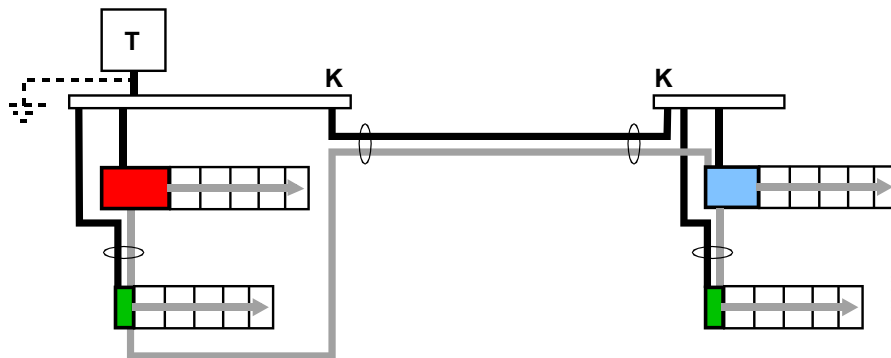

### 6.5.3 Example: 2 transformers, 1 or 2 control panels

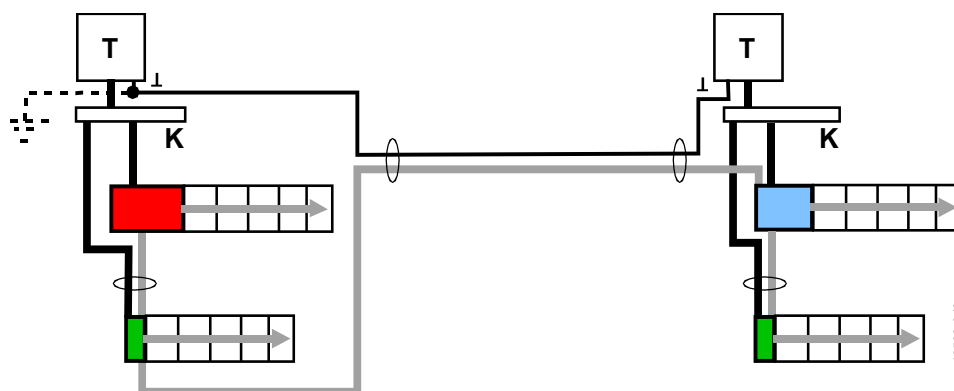

- Note
- System neutral of the two transformers must be connected as close as possible to the transformers.

### 6.5.4 Example: New power supply (module supply or AC 24 V)

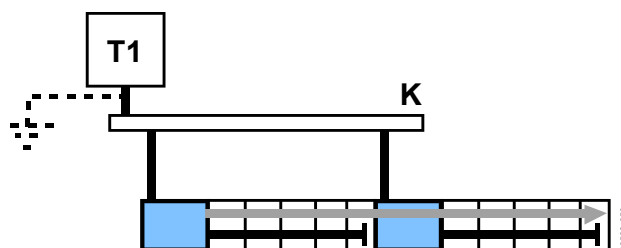

- Notes
- A new provision is required in the following cases (for details refer to Section 10.3):
    - When the admissible supply current of 1.2 A in the **module supply** is "used up" by the I/O modules and the field devices: a new power supply module is required (operating in parallel with the first one).
    - When the admissible supply current of 6 A in the **field supply** is "used up" by the field devices: a new power supply module or bus connection module is required.
    - New circuit with separate fuse.
  - The CS and CD conductors of the power supply modules and bus connection modules are connected internally, so that these are available to the whole I/O row.
  - The field supply (AC 24 V) has no bus connector on the left side, so that only the I/O modules to the right are supplied.



## 6.6 Connecting the field devices

---

### Cable materials

- 2-core cable without shield.
- Single cores are not admissible, either inside or outside the control panel.

### Cable length and cross-section



Caution!

- The length and cross-section of the cables are limited by the following criteria:
  - Line resistance in conjunction with the measured-value inputs for resistance sensors (LG-Ni 1000, Pt 1000)
  - Voltage drop in conjunction with measured-value inputs for active sensors (DC 0...10 V) and positioning outputs (DC 0...10 V)
  - Potential short circuit current on conductor 24 V~ in case of active sensors and triacs (10 A fuse in the power supply module / room automation station).
    - Use cable cross section suited for 10 A according to local regulations!
  - Noise interference from adjacent cables in all module types.
- For details of the specific type of cable and cable cross-section appropriate to each case, refer to the project-specific documentation.
- Basic information for the calculation: see Sections 10.11 ff.

### Cable routing

- The cables going out into the field may be routed, without screening, together with other cables (including AC 3 x 400 V power cables) in the same cable trunking for example.
- However, refer to the notes on routing the island bus cable (Section 6.4.2) in this context.
- Exceptions to this guidance are detailed in the project-specific documentation.

### Counter inputs



- **Counter inputs faster than 1 Hz that are routed for more than 10 m in the same trunking as analog inputs must be shielded.**

### System neutral terminals (⊥)

- All system neutral terminals of a module are interconnected, *not* in the terminal base but in the plug-in module. When this unit is unplugged there is no connection.
- The system neutral of a **digital input** can be connected to any signal neutral terminal of the module.
- It is also permissible to combine the system neutral conductors of several digital inputs in order to save wire.  
However, **system ground** must be connected **at least once per module**.  
For details refer to Section 10.11.
- With **analog inputs and outputs**, the measuring neutral must always be connected to the terminal associated with that specific I/O point to avoid possible measurement errors.
- **DC 0...10 V actuators with DC 0...10 V feedback:**  
System neutral ⊥ of output and feedback may be in the same conductor due to the small current of the U10 and Y10 signals. However, output and feedback must be on the same I/O module and there is no DC 24 V supply current admissible on the ⊥ conductor.

### Connection terminals

- The terminal bases of the I/O modules act as terminal strips for the connection of the devices outside the control panel, and comply with the relevant standards. This eliminates the need for the separate control panel terminal strips normally required for this purpose.

### Unswitched mains voltage

- This is not available on the bus and must be supplied separately.

### Mains voltage for field devices

- Relay modules have volt-free relay contacts.  
The mains voltage / switching voltage must be supplied as an external voltage to the terminals in the terminal base.

## 6.7 EMC compliant wiring

---

Please refer also to Section 5.3 "EMC compliant control panel".

### Wiring rules

In control panels or buildings where severe electromagnetic interference (EMI) is likely, devices susceptible to interference can be better protected by observing the following rules for wiring:

### Control panel wiring

- Inside the control panel the connection terminals and cable trunking for **unscreened** conductors must be routed separately from **screened conductors**.
- Avoid cable loops.
- Provide sufficient space for correct connection of the cable screens.
- Connect cable screens directly to the control panel at the point of entry into the control panel. Leave the screen intact up to the module.
- Make the control panel part of the equipotential bonding system in the building.

### Building wiring

Different types of cable in the same trunking

When organizing the cable trunking, ensure that any cables emitting high levels of interference are routed separately from cables susceptible to interference.

Cable types

- Interference-emitting cables: Motor cables, energy cables.
- Interference-susceptible cables: Control cables, low voltage cable, interface cables, LAN cables, digital and analog signal cables.

Segregating the cables

- Both categories of cable can be routed in the same cable trunking, but in separate compartments.
- In the absence of partitioned trunking enclosed on three sides, the interference-emitting cables must be separated from other cables by at least 150 mm, or routed in separate trunking.
- Where interference-emitting cables intersect with cables which are susceptible to interference, they should cross at right-angles.

Unscreened cable

- Follow the recommendations of the manufacturer when selecting screened or unscreened cable. In general, **unscreened, twisted-pair cable** has adequate EMC properties for building services applications (including data applications).
- For the **island bus** (conductors CS and CD), unscreened round cord is admissible.
- Unscreened cables have the added advantage that there is no need for concern about earth coupling.

Screened cable

Screening enhances the EMC immunity. However, the following rules must be observed:

- The purpose of the earthing procedure (common reference point) is to dissipate and short-circuit interference voltages conducted by the cable screens.
- Careful attention must be paid to the earthing strategy in order to avoid earth looping or differences in potential.
- To avoid low frequency interference, screens must be earthed on one end only.
- To avoid high frequency interference, screens must be connected at both ends to the earth mass. However, equipotential bonding via the cable screens must be avoided. In the absence of equipotential bonding (e.g. with connections between buildings over large distances) a separate equipotential bonding system must be installed. Alternative: hard wired earthing on one side, via a capacitor on the other side.
- For effective screening, it is important that the cable screen is properly connected to the earth mass (see below).
- Island bus expansion: refer to section 10.6.

- Notes
- For more information, refer to Section 5.3 "EMC compliant control panel".
  - Special rules for connecting the screen apply in environments exposed to explosion hazards.

**Ethernet cables for PROFINET BIM**

**Fixing the cables in the control panel**

**Screened cables are compulsory!**

The cable screens of screened conductors must be connected to the metal structure of the control panel at the point of entry to the control panel, and to the equipotential bonding system of the building.

The following diagrams show the correct connection of screened and unshielded cables to the earth rail and cable fixing rails.

Use only standard commercially available screen-connection terminals to ensure good connections.

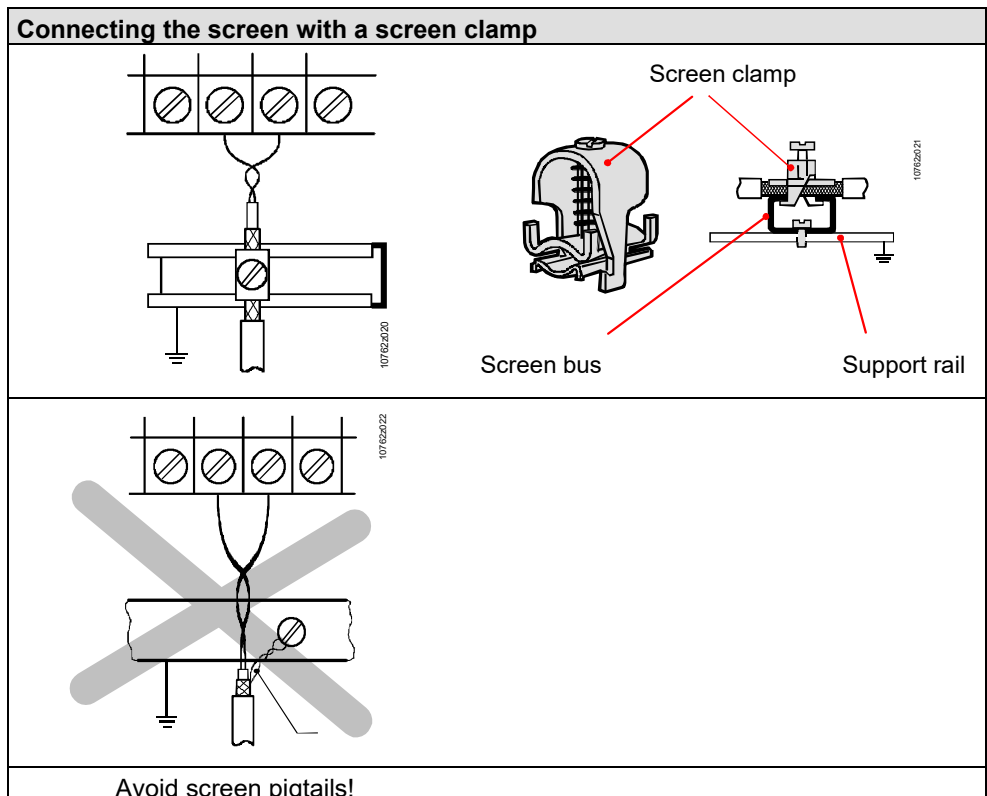
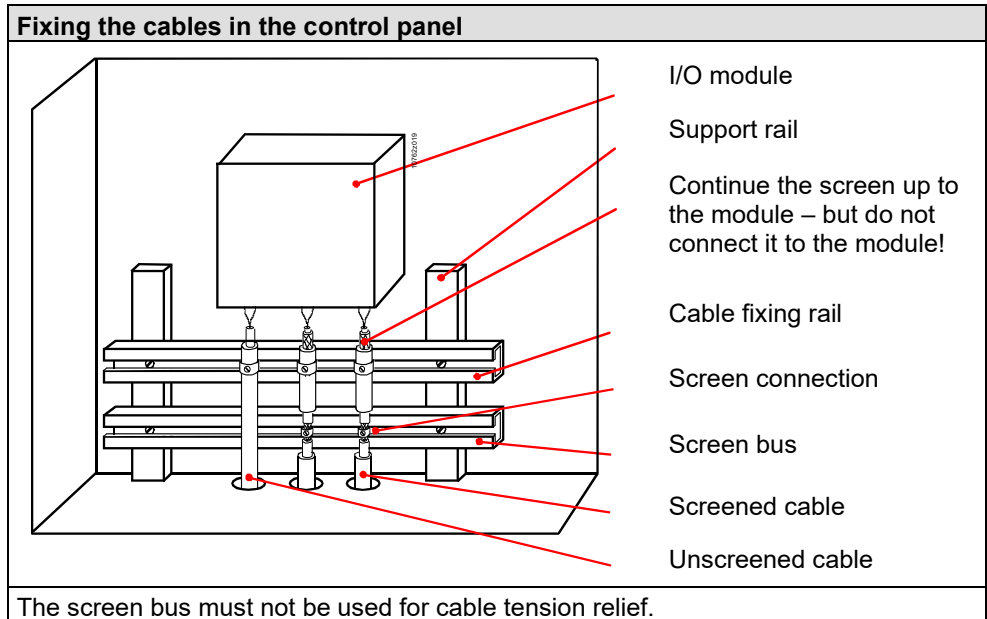

# 7 Checking activities

## Introduction

- The following check lists apply to the fully installed control panel on the panel builder's site (not to the control panel on the customer site with all the external wiring).
- The proposed sequence is intended as an aid to efficient working.

## 7.1 Location and installation of equipment

### Layout in the control panel

Check the layout of the equipment as follows:

Ref.	Item	OK
1	Does the breakdown and sequence of the module groups and module types in separate I/O rows comply with the details in the documentation?	

### Installation of I/O modules and accessories

Check the installation of the I/O modules and accessories as follows:

Ref.	Item	OK
1	Are the support rails firmly secured to the mounting frame?	

### Visual inspection

Check the wiring for the following points:

Ref.	Item	OK
1	Have all the wire connections specified in the diagram been made inside the control panel?	
2	In situations with more than one AC 24 V transformer per I/O island: Are the system neutral conductors ( $\perp$ ) of the transformers interconnected?	
3	Is each power supply module supplied directly from the transformer?	
4	Is the system neutral ( $\perp$ ) earthed/not earthed as specified in the plant wiring diagram?	
5	Island bus: Are the CS and CD conductors two-core cables as specified? Single wires must <b>not</b> be used.	
6	Do the connection terminals used comply with the wiring diagram?	
7	Have all the terminal screws been tightened?	
8	Has a "pull test" been carried out on all connecting wires?	

### Electrical check

Check the electrical connections as follows:

Ref.	Item	OK
1	Disconnect the equipment as follows: Unplug the I/O modules, leaving them in the "parked" position.	
2	Carry out a point-to-point check of the connecting cables with an optical or acoustic signal transmitter.	
3	Carry out any insulation testing required in accordance with the regulations. To this end, replace the devices required by the regulations.	
4	Replace all items removed in Step 1.	

## 7.2 Power supply

### Safety precautions and equipment specification

Check that device protection and specifications comply with the regulations below:

Ref.	Item	OK
1	If the mains voltage is connected to the I/O modules (max. 10 A): Does the device protection comply with the regulations?	
2	Protection of the 24V~ operating voltage: Is the transformer fitted with a fuse for the 24V~ conductor (system potential) and, where applicable, also for the $\perp$ conductor (system neutral)? Do these fuses comply with the values shown in the plant diagram? (Effective load of the connected control panel and field devices)	
3	Does the AC 24 V transformer rating shown on the type plate at least match the transformer power indicated in the plant diagram? (power supply for all the control panel equipment including the connected field devices)	
4	Does the AC 24 V transformer type plate indicate that it is a double-insulated safety transformer in compliance with EN 61 558 designed for continuous operation?	

### Supply voltage

Check, as follows, that the devices are supplied with the required voltage:

Ref.	Item	OK
1	Local regulations applicable to work on an open control panel must be observed!  Switch on the supply voltages.	
2	The following voltages must be available in the terminal bases: <ul style="list-style-type: none"> <li>• AC 24 V operating voltage between 24V~ and <math>\perp</math></li> <li>• A direct current of approx. DC 24 V between CS and <math>\perp</math> (delivered by the power supply module)</li> </ul> The voltages can be checked via the test pick-ups (test terminals) on universal and super universal modules.	

## 7.3 Labeling and addressing

### Labeling

If plant-specific labels have been supplied, check their allocation to the various devices by reference to the engineering documents (plant diagram, module list, control panel layout etc.):

Ref.	Item	Check	OK
1	Plug-in module	Does each inserted label match the address and function of the module concerned?	

### Addressing

Ref.	Item	OK
1	Is the address number on the address key in the I/O module the same as the address number on the I/O module label?	

## 7.4 Wiring test with unconfigured I/O modules

See also Section 9.5 (diagnostics).







The wiring test is best performed with unconfigured I/O modules (with DC 24 V supply present and address key swiveled inward – bus manager not required).

The default functions (factory-set I/O module status) have been specially designed for optimal testing. With configured modules, each I/O point would react differently according to the signal type.

### Default functions of the modules

Module	Type	Default function	Equivalent function
Digital input module	TXM1.8D, TXM1.16D, TXM1.4D3R	BI Default	BI NO / D20
Universal module	TXM1.8U, TXM1.8U-ML	UIO Default	Description see next page
Super universal module	TXM1.8X, TXM1.8X-ML	UIO Default	Description see next page
Resistance measuring module	TXM1.8P	RI Default	Description see next page
Relay module	TXM1.6R(M), TXM1.6RL, TXM1.4D3R	BO Default	BO Relay NO 250V / Q250
Triac module	TXM1.8T	BO Default	BO Triac NO
Blinds module	RXM1.8RB	MO Default	4 x MO Steps (2-stage) / Q-M2

### Testing options with default functions

Test	Action	I/O status LED	LCD display	Remark
Testing of inputs	<b>TXM1.8D, 16D, 4D3R</b> (BI Default)			
	Shorting the input	ON		
	<b>TXM1.8U (-ML), TXM1.8X (-ML)</b> (UIO Default)			
	No voltage (input open or shorted)	OFF		
	-75 ... +75 µA at input	OFF		<b>High-resistance</b> conductivity tester → <b>Do not use!</b>
	>75 µA at input	ON		Correct polarity of <b>low-resistance</b> conductivity tester (buzzer)
	< -75 µA at input	Flashing 1 Hz		Incorrect polarity of <b>low-resistance</b> conductivity tester (buzzer)
	>11.5 V at input	Flashing 1 Hz		E.g. DC24 V connected by mistake
	AC24 V at input	Flashing 1 Hz		AC24 V connected by mistake
	<b>TXM1.8P</b> (RI Default)			
	< 40 Ohms on input	ON	(no LCD)	Especially short circuit
	> 40 Ohms on input	OFF	(no LCD)	
	Testing digital outputs	<b>TXM1.6R (-M), TXM1.6RL, TXM1.8T, TXM1.4D3R</b> (BO Default)		
Local override or tool override enabled		ON / OFF	The module performs all local overrides (local override, tool override) directly, without safety precautions or interlocks. → <b>Special care is required</b> ←	
<b>TXM1.8RB</b> (4 x MO Steps (2-stage) / Q-M2)				
	Tool override enabled	OFF / Stage 1 / Stage 2		
Testing analog outputs	<b>TXM1.8U (-ML), TXM1.8X (-ML)</b>	UIO Default is an input function. For safety reasons, planned analog outputs can not be tested with unconfigured modules. As soon as the modules are configured, you can use the functional tests described in CM110561.		

## 7.5 Other function checks

### Without bus manager

If the modules are supplied with DC 24 V, the following operations can be performed with the **local override facility** of the modules (only outputs can be overridden):

- if not configured: default function
- if already configured: configured function if override permitted.

### With automation station

- The functions of the I/O modules / field devices can be checked from the automation station. The procedure depends on the system and is described in the associated documentation.

### With BIM Tool

- The functions of the I/O modules / field devices can be checked from the BIM Tool. The procedure is described in the TX-I/O engineering documentation [6], [9].
- The BIM Tool can also simulate field devices for the automation station before they are physically connected to the terminals
- No BIM tool / no simulation function available for PROFINET BIM

Ref.	Item	Check	OK
1	Check I/O module functions	Are the functions as specified in the project documentation?	
2	Check field device functions	Are the functions as specified in the project documentation?	

## 7.6 Control panel delivery check

### I/O modules and documentation

After inspection in line with the check lists above, the control panel and installed I/O modules must be prepared for delivery as follows:

Item	Requirement	OK
I/O modules	All modules with local override facilities must be set to automatic operation	
Engineering documentation	The project-related documents and the documentation for installing and connecting the I/O modules in the control panel must be complete and accommodated neatly in the control panel.	

Note The project documentation must include a record of the "as delivered" state of the installed automation stations and bus interface modules.

### Acceptance criteria

The criteria for acceptance are the professional and appropriate mounting and wiring of the I/O modules in the control panel in accordance with

- the information in this engineering and installation manual, and
- the implementation documents accompanying the order.

### What to do in the case of missing products or information

In the case of missing products, insufficient or non-existent information in the implementation documents etc., please get in touch with the contractor as soon as possible.

If these problems prevent you from carrying out any part of the work, despite contacting the contractor, you should proceed as follows:

- Make a written note of the situation
- Attach this note in an easily visible location in the control panel.

# 8 Commissioning notes

---

## Warning

Before commissioning, the checks applicable to the I/O module system must be carried out as described in Section 7.

This is particularly important in relation to checking for incorrect wiring which could put people or property at risk. See also Section 2, "Safety guidelines".

## Removing and inserting modules without disconnecting the power

The plug-in modules can be removed from or plugged into the terminal bases without switching off the power (but not suitable for frequent action – risk of burnt contacts between terminal base and plug-in module, if large loads are connected to the terminals).

However, note the warning on page 33, if you plug in a different, previously used module!

## Emergency operation via override

In the event of a bus communications failure, emergency manual operation is possible in I/O modules with local override facilities. However, the DC 24 V module supply must be present.

## Safety isolation

**The override buttons on the switching and positioning outputs must not be used as safety isolators, e.g. for service or maintenance purposes. Use suitable emergency switches instead.**

## Function check

The functions of the I/O modules can be checked with the BIM Tool:

The procedure for checking from the automation station depends on the building automation and control system concerned, and is described in the associated documents.

## 8.1 Response on module start-up

---

### Power\_OFF

The modules assume the Power\_Off status when the supply to the module drops below 16 V, or is not yet above 21.5 (hysteresis).

- The LEDs and LCDs are off
- The modules are inactive.

### Power\_UP

The modules start up when the voltage rises above 21.5V.

The associated steps are as follows:

- Module status LED lights up, LCD reads the address number for approx. 2 s
- Status LED shows the last operating state before Power\_Down
- If communication is OK:
  - **Integration via island bus or PROFINET BIM:** operation with configurable values, see [4]
  - **Integration via P-Bus BIM :** operation as before Power\_Down
- If no communication: Wait 4 seconds for communication
  - No control of outputs
- If no communication after 4 seconds:
  - **Integration via island bus or PROFINET BIM:**
    - Operation with backup values
    - Local override is possible
    - Local override may be disabled in the configuration

## 8.2 Response after reset

---

<b>Prerequisite</b>	The DC 24 V supply must be connected.
<b>Description</b>	<p>The module responds as follows after inserting and swiveling the reset key inward:</p> <ol style="list-style-type: none"><li>1. All I/O status LEDs light up for approx. 1 s</li><li>2. After the reset, the modules behave as unconfigured modules (factory settings = default function for each I/O Point). Override settings due to local override are deleted.</li></ol>
<b>In which cases is a reset needed?</b>	<ul style="list-style-type: none"><li>• Replacement of a plug-in module by a previously used one (see 4.4)</li><li>• Force the bus manager to re-configure a module (depending on the number of modules in the island, this will take less than 10 seconds).</li></ul>

## 8.3 Response in other states

---

<b>Swiveling the address key out</b>	<p>When the address key is swiveled out, the module is totally inactive, and it cannot be overridden locally (address key = "main switch" if the module).</p> <p>The state (automatic operation, tool override or local override) and the configuration and parameters of the individual I/O points are saved in the non-volatile memory of the plug-in module. In the event of local or tool override, the process values are saved as well.</p>
<b>Resetting tool override mode</b>	<p>Individual I/O points can be overridden by means of the BIM Tool (indicated by the module status LED flashing, see page 66). You can return to automatic operation by disabling the tool override in the tool, or by enabling the local override on the module, which has higher priority than tool override, and disabling it immediately.</p>
<b>When fault is repaired / address key swiveled back</b>	<p>Operation in the same state as before (automatic operation, tool override or local override). The process values are only stored in tool override or local override. (Details see CM110561).</p>
<b>Faults</b>	<p>The behavior in the event of failure and return of bus communications, bus supply DC 24 V, and field supply AC / DC 12 ... 24 V is described for the individual I/O functions in [4]. See also Section 9, "Display, operation, and diagnostics" in this document.</p>
<b>Oscillating of the modules in case of overload</b>	<p>Relays and current outputs have a power consumption that depends on the supply voltage (module supply DC 24 V). The power consumption of an I/O island will rise when all relays are active and all current outputs deliver 20 mA. This will cause a drop in the supply voltage.</p> <p>If too many of these outputs are configured (despite the limits in XWP / DTS), the voltage may drop too much so that all modules will switch off. Upon this, the voltage will recover, the modules will switch on again, and so forth, 1 to 2 times per second.</p> <p>In this case the automation station / the P-Bus BIM will react by switching off the communication after 5 cycles (shortcut between CD and CS, the COM LED will light brightly).</p> <p>Reset: Switch off the AC 24 V supply of the P-Bus BIM and switch it on again.</p>

Note *Feature "Short circuit of island bus" is not available for PXC...D and Simatic.*

# 9 Display, operation, and diagnostics

## 9.1 Indication and display of the I/O modules

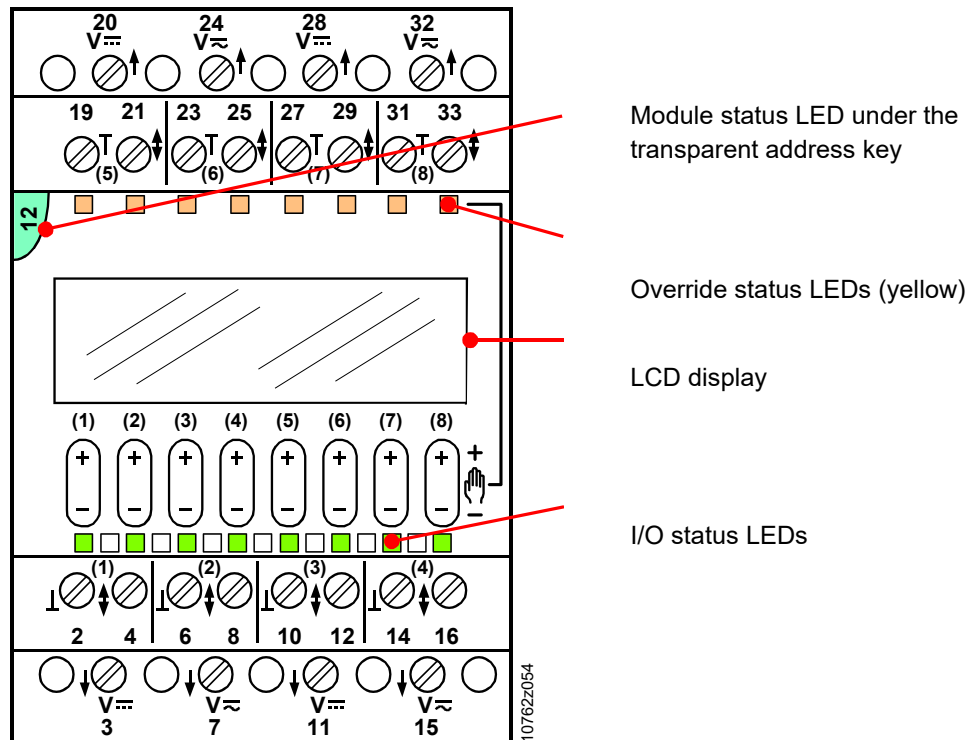

### Module status LED

- The module status LED (green) is located on the I/O module under the transparent address key. It shows the module status as a whole (as opposed to the I/O points).
- This LED is also used for diagnostics.

### I/O status LEDs

- The I/O status LEDs (green) indicate the status of the inputs and outputs (field devices).
- The LEDs are labeled with the I/O point number.
- On certain module types the LEDs are three-colored. If the I/O function supports it, the LED can display Alarm = Red and Service = Yellow, in addition to Normal = Green.
- These LEDs are also used for diagnostics.

### Override status LED

- The yellow status LED indicates that local override is active (see below under "Local override").

### LCD display

- The following information is displayed for each I/O point:
  - Configured signal type (lower part of display)
  - Signal value (process value) (graphics-supported display of pulse or analog value)
  - Faults (incorrect operation, short-circuit, open sensor circuit, etc.).

Examples

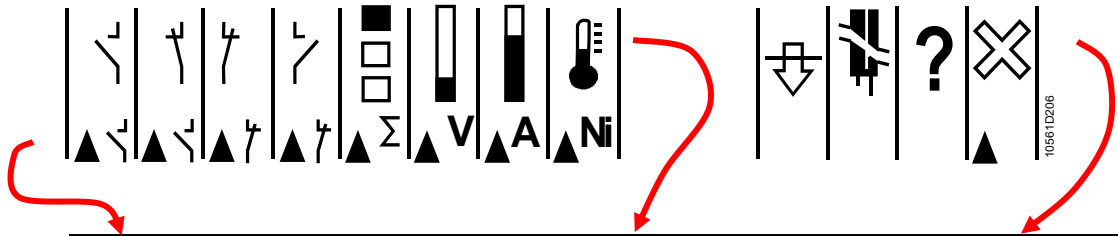

Display elements

Configured signal type	Signal value	Errors, reminders
▲  Digital input, N/O contact	<ul style="list-style-type: none"> <li>• Open (inactive)</li> <li>• Closed (active)</li> </ul>	Above range limit
▲  Digital input, N/C contact	<ul style="list-style-type: none"> <li>• Closed (inactive)</li> <li>• Open (active)</li> </ul>	Below range limit
▲ $\Sigma$ Counter input	Step indicator for counter pulses	Open circuit
▲  Pulse input, N/O contact	Step indicator for switching pulses	Short circuit
▲  Pulse input, N/C contact		Illegal action (local override)
▲ $V$ Measuring input, voltage	Low / high value (voltage, current)	No current sensor (during wiring test: AC 24 V)
▲ $A$ Measuring input, current		Insecure (or no) output signal
▲ $Pt$ Measuring input (temperature, resistance ( <i>P-Bus BIM</i> also resistance))	Temperature symbol (Ni, Pt, NTC sensor), resistance	Insecure general
▲ $Ni$ Measuring input (temperature)		I/O point inactive (reminder, during start-up only)
▲ $T1$ Measuring input (temperature)		Invalid process value
▲ $Ntc$ Measuring input, temperature		
▲ $\Omega$ Measuring input, resistance	Resistance variable display	
▼ $V$ Analog output, voltage	Low value (voltage or current)	
▼ $A$ Analog output, current	High value (voltage or current)	
▲  Wiring test or unconfigured	No voltage / voltage present, details see page 55	

10561D206

- 1) Insecure Output Signal
  - Voltage outputs: the AC/DC supply for field devices is low or not available; therefore reliable operation of external devices cannot be guaranteed)
  - Digital outputs (relays): the internal module operating power is low or not available; therefore reliable operation of the relay cannot be guaranteed
  
- 2) Insecure General
  - Voltage input signal types: the AC/DC supply for field devices is low or not available
  - Current inputs: the DC 24 V field supply is low.
  
- 3) I/O Point inactive
  - Only during startup (before the module is polled or for max 4 s startup time): After this, the ASIC is configured and working.
  
- 4) Invalid Process Value
  - The I/O function does not operate (e.g. directly after startup if the ASIC does not provide any values)

## 9.2 Indication and display of the other island bus devices

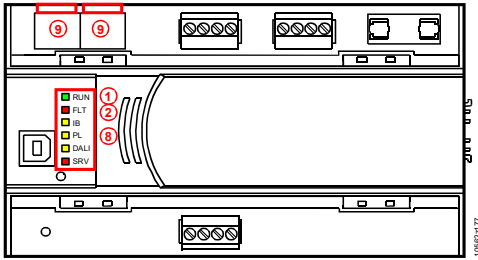

PXC3... Room automation station with island bus connection

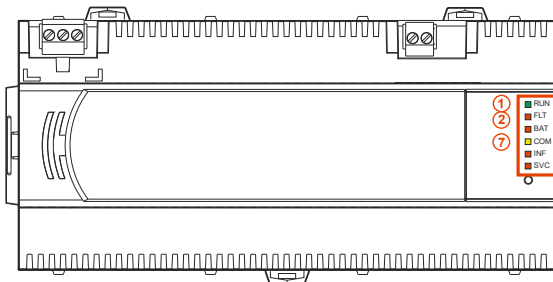

PXC...D Automation station with island bus connection

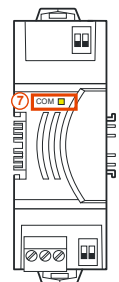

TXA1.IBE Island bus expansion module

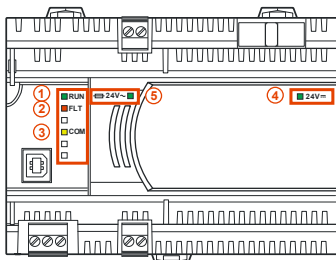

P-Bus Interface- module (BIM)  
TXB1.PBUS

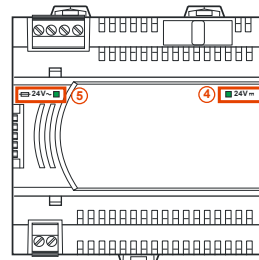

Power supply module  
TXS1.12F10



Bus connection module  
TXS1.EF10

**PROFINET BIM:** see document CM110564, TX-I/O PROFINET BIM V1.0 – User's guide

**PXC3...** : see data sheet N9203 for details

- ① **RUN (green)**
  - The LED lights up when the CPU of the bus manager is running.
- ② **FLT (red)**
  - The LED lights up in the event of a fault (see below)
  - It flashes slowly (FI\_3) if there is no configuration in the I/O island
  - It flashes quickly (FI\_5) while configuring the modules and while the BIM Tool creates an Island bus report (Flashing patterns FI\_x see page 66)
- ③ **COM (yellow)**
  - Indicates P-bus communication (irregular flashing)
- ④ **Module supply LED**
  - Indicates DC 24 V module supply / field supply:
  - ON Module supply OK
  - OFF Module supply OK
  - Details see Section 9.5.
- ⑤ **Fuse LED for field supply**
  - Indicator for AC 24 V supply to supply module and field supply:
  - ON AC 24 V (supply voltage) input present, and fuse OK
  - OFF No AC 24 V (supply voltage) input, or Fuse blown



**⑥ Fuse LED**  
for field supply

Indicator for field supply voltage  $V_{\approx}$ :

ON  $V_{\approx}$  (field supply voltage) input present (> 22 V), and Fuse OK  
*Voltage <22V are not indicated!*



OFF No  $V_{\approx}$  (field supply voltage) input, or fuse blown

(Bus connection module only)

**⑦ COM (yellow)**

Indicates island bus communication

- Irregular flashing communication island bus
- Brightly ON Reset / short circuit on island bus, all modules are inactive
- Permanently OFF No supply /no communication / island bus expansion not wired

**⑧ IB (yellow) Island bus**

Indicates communication

**PL (yellow) PL-Link**  
**DALI (yellow)**

- Flashing Communication
- Permanently ON OK
- Permanently OFF Bus not used (bus power supply disabled via software) or communication fault

**⑨ Ethernet 1 / 2**

Indicates communication

Green	Continuously ON	Link active
	Continuously OFF	Link inactive
	Flashing	Network activity
Yellow	Continuously ON	Link 100 Mbps
	Continuously OFF	Link 10 Mbps

## 9.3 Local override

---

- The local override facility is available only on certain modules.  
In principle, plug-in I/O modules with and without a local LCD panel/operator controls are compatible and interchangeable.
- **Only outputs can be overwritten. Any attempt to overwrite an input results in an error indication.**
- Local override also operates without a bus manager, provided that the DC 24 V module supply is present and the address key is plugged in.
- With a change from automatic mode to local override, the last state is retained. The automation station resumes control when the system is switched back to Auto.
- The bus manager is notified of local overrides and the associated values, and they are permanently saved in the module.
- Local override may be disabled in the configuration



Warning

- **All safety-relevant functions must be implemented with external solutions.**
- **The local override must not be used for safety shutdown operations.**
- **In compliance with the standard (ISO 16 484-2, Section 3.110), the module performs all local overrides directly, without safety precautions or interlocks.**  
→ Full responsibility lies with the operator. ←

### 9.3.1 Override button

---

Pressing an override button in the middle enables or disables the local override (press until the override status LED changes to ON or OFF).

When local override is enabled:

- Pressing "+" increases an output value or activates the relay.
- Pressing "-" reduces an output value or disables the relay.
- Repeated or sustained pressure changes the value by several stages until the function stops at the highest/lowest stage.
- The I/O status LED and LCD display change accordingly.

Pressing "+" or "-" when local override is disabled produces an "error" indication.

### 9.3.2 Override status LED

---

The yellow "Override" LED indicates for each I/O point that local override is active:

Description	LED (yellow)
Normal (automatic operation)	OFF
Local override active	ON
multi-stage function	<ul style="list-style-type: none"><li>• The LEDs of all the associated I/O points are ON.</li><li>• The function can be overridden on any I/O point.</li></ul>
Reminders, errors	See below under "Diagnostics".

### 9.3.3 Priority

---

Local override has first priority, followed by tool override via TX-I/O Tool, and function test via BIM Tool, and (lastly) automatic mode via process value / backup value.

## 9.4 Display



### 9.4.1 Overview: indication per signal type / I/O function

	Signal type (Signal type designations see section 1.6.1)	Range (Under / over range)	I/O LED	LCD	Error indication					
					Shorted	Under range	Over range	Open circuit	No current sensor	Unreliable (general) 3)
Resistance & temperature	AI Pt1000	0 ... 2500 Ω	OFF	Sensor type	x	x				
	AI Pt100 2)	0...250 Ω	OFF	(no LCD)						Kein LCD **)
	AI 2500 Ohm	0...2500 Ω	variable	variable	x	x				
	AI 250 Ohm 2)	0...250 Ω	variable	(no LCD)						Kein LCD **)
Temperature measurement	AI Ni1000	-50...150 °C	OFF	Sensor type	x	x	x	x		
	AI Ni1000 extended	-50...150 (180) °C 1)	OFF	Sensor type	x	x	x	x		
	AI PT1K375	-50...150 (180) °C 1)	OFF	Sensor type	x	x	x	x		
	AI PT1K385	-50...400 (600) °C 1)	OFF	Sensor type	x	x	x	x		
	AI Pt100 4 wire 2)	-50...400 (600) °C 1)	OFF	(no LCD)						Kein LCD **)
	AI NTC10K	-50 ... +130 (150)°C 1)	OFF	Sensor type	x	x	x	x		
	AI NTC100K	-40...115 °C	OFF	Sensor type	x	x	x			
	AI T1 (PTC)	-40...125 °C	OFF	Sensor type	x	x	x			
Voltage measurement	AI 0-10V	0...10 V	variable	variable	x	x	x	x		
Current measurement	AI 4-20 mA	4...20 mA	variable	variable	x	x			x	x
	AI 0-20 mA 4)	<b>0...20 mA</b>	variable	variable	x	x				
Wiring test (see Section 7.4)	UIO Default	-75...+75 μA	OFF, ON, Flashing	<b>0 / +</b>	x	x			x	
Voltage output	AO 0-10V	0...10 V	variable	variable	x	x				x
Current output	AO 4-20 mA	4...20 mA	variable	variable	x	x				
PWM	AO PWM	0...100 %	variable	(no LCD)	x	x				x
Digital inputs			On / Off	(page 60)						--
Digital outputs			On / Off	--						--

- 1) (extended range) only with reduced hum injection, see page 115
- 2) The signal types AI Pt100 4 wire and AI 250 Ohm only run on the TXM1.8P module which has no LCD display
- 3) The error indication "unreliable (general)" is displayed in the following cases:
  - No **AC/DC 24 V** for field supply (AI 0-10V)
  - No **DC 24 V** for field supply (AI 4-20mA, AI 0-20mA)
The error indication "unreliable output signal" is displayed when:
  - No **DC 24 V** for field supply (AI 0-10V)
- 4) 0...25 mA see CM110563.

## 9.4.2 LED behavior

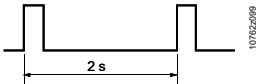
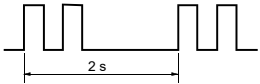
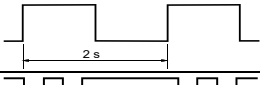
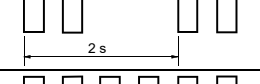
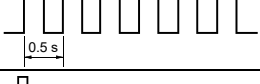
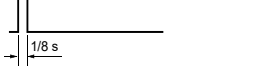
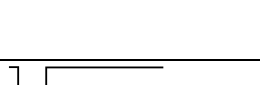
LED states	Cause	Module status LED	I/O status LED	Override status LED	Fault LED (Bus manager)	COM LED (Bus manager)
OFF	<ul style="list-style-type: none"> <li>No voltage</li> <li>Binary value indication (Off)</li> <li>No fault</li> <li>Local override off</li> </ul>	X	X X	X  X	X  X	
Variable intensity	<ul style="list-style-type: none"> <li>Indicates analog value</li> </ul>		X			
ON	<ul style="list-style-type: none"> <li>Supply voltage present</li> <li>Green: binary value indication (On)</li> <li>Other colors: if supported by signal type and module</li> <li>Local override</li> <li>Invalid configuration (flashing patterns see below)</li> </ul>	X	X X	X	X	
Pulse	<ul style="list-style-type: none"> <li>Activity</li> </ul>		X			
Briefly off	<ul style="list-style-type: none"> <li>Local override action</li> </ul>			X		
Irregular	<ul style="list-style-type: none"> <li>Communication on P-bus</li> </ul>					X

LED flashing patterns (faults, information) (FI_x = number of the flashing pattern)			Cause	Module status LED	I/O status LED	Override status LED	Fault LED (Bus manager)	COM LED (Bus manager)
FI_1	Pulse		Module unconfigured, no address key	X	X			
FI_2	Dual pulse		Module configured, no address key	X				
FI_3	Flashing 0.5 Hz		<b>Faults (Details are shown on the LCD)</b>	X	(X)		X	
FI_4	Dual off pulse		Information: Tool override	X				
FI_5	Rapid flashing		Configuration, "Island bus report" creation				X	
FI_6	Short pulse		Information: <ul style="list-style-type: none"> <li>Local override is off; operation is not possible (output)</li> <li>Local override not permitted (input)</li> </ul>			X		
FI_7	Short OFF pulse		While override button is depressed			X		
FI_8	Short flashing 2 Hz		Information: Local override disabled → local override is not admitted			X		

### Principle for faults

- When a fault concerns the **module**, the module status LED flashes (pattern FL\_3).
- When a fault concerns an **I/O point**, the I/O status LED and the module status LED flash synchronously (pattern FL\_3).

### **9.4.3 General: LCD graphics**

---

- For a detailed description of normal operation, see above, page 60.
- For diagnostics, see below.

### **9.4.4 Start-up and reset response**

---

See Section 8.

## 9.5 Diagnostics based on the LED indicators – (integration via island bus)

Faults and information, based on the example of an I/O island with one automation station and two power supply modules (Supply 1 and 2)

DISPLAY							FAULT / INFORMATION	DETAILS		
Autom. station		Supply 1		Supply 2 1)		Modules 4)		DC24V from bus 2)		
RUN LED	FAULT LED 3)	AC24V LED	DC24V LED 2)	AC24V LED 1)	DC24V LED 2)	Module status LED 2)	Other LEDs			
<b>A) Operation, configuration, communication etc.</b>										
ON	OFF		ON			ON	Normal	> 21.5V	No fault	Normal operation
ON	OFF		ON			ON	OVR LED ON	> 21.5V	No fault	Local override ON
ON	OFF		ON			FI_4	Normal	> 21.5V	No fault	Tool override on at least one I/O point of the module is
ON	FI_5		ON			ON	Normal	> 21.5V	No fault	Configuration, island bus report (indication throughout process)
ON	OFF		ON			FI_3	I/O LED FI_3	> 21.5V	Invalid signal (e.g. short circuit or open circuit)	<ul style="list-style-type: none"> <li>Synchronous flashing</li> <li>Details on LCD panel, if any (see page 60)</li> </ul>
ON	OFF		ON			ON	OVR LED FI_6	> 21.5V	Illegal operation	e.g. attempt to operate an input or an output where local override is not activated
ON	OFF		ON			ON	OVR LED FI_8	> 21.5V	Illegal operation	e.g. attempt to operate an input or an output where local override is disabled (configuration)
ON	OFF		ON			FI_3	Normal	> 21.5V	Faults that are not in relation to an I/O point	<ul style="list-style-type: none"> <li>Address key inserted</li> <li>All module related faults</li> </ul>
ON	ON		ON			OFF	All OFF	> 21.5V	Module in parked position	Module inactive
ON	FI_3		ON			FI_3	Normal	> 21.5V	No configuration	All modules have Default functions
ON	ON		ON			ON	Normal	> 21.5V	Configuration error	<ul style="list-style-type: none"> <li>At least one module has incorrect configuration</li> <li>Multiple module addresses or permutations, etc.</li> </ul>
ON	ON		ON			FI_1	All OFF	> 21.5V	No address key and not configured	<ul style="list-style-type: none"> <li>At least one module unconfigured = AS Fault LED ON (Module configured = at least 1 I/O point configured)</li> <li>If unconfigured channels not used by application: No fault (AS Fault LED OFF; module status LED and I/O Status LEDs do not flash)</li> </ul>
ON	ON		ON			FI_2	All OFF	> 21.5V	No address key and configured	At least 1 I/O point is configured
ON	ON		ON			FI_3	Normal	> 21.5V	<ul style="list-style-type: none"> <li>Address key inserted</li> <li>Not configured</li> <li>Communications error</li> <li>EMC fault</li> </ul>	Examples of communication errors: <ul style="list-style-type: none"> <li>Bus not connected</li> <li>Bus short-circuit</li> <li>Voltage drop on bus cables is too high</li> </ul>

DISPLAY									FAULT / INFORMATION	DETAILS
Autom. station RUN LED	FAULT LED 3)	Supply 1 AC24V LED 2)		Supply 2 1) AC24 V LED 2)		Modules 4) Module status LED 2)		DC24V from bus 2)		
<b>B) Power supply</b>										
ON	OFF	ON	ON	ON	ON	ON	Normal	> 21.5V	Normal operation	An eventually defective supply in a power supply module is not recognized as long as DC 24 V > 21.5 V
ON	ON	ON	ON	ON	ON	FI_3	Normal	16 ... 20.5	Supply overloaded 2), 4)	Modules still operate, but send a message "voltage low"
ON	ON	ON	ON	ON	ON	OFF	OFF	< 16 V		Modules are inactive
OFF	OFF	ON	ON	ON	ON	FI_3	Normal	> 21.5V	AS not connected (AC 24 V) 2)	No communication, sufficient power
OFF	OFF	ON	ON	ON	ON	FI_3	Normal	16 ... 20.5		No communication, insufficient power
OFF	OFF	ON	ON	ON	ON	OFF	OFF	< 16 V		Modules are inactive
OFF	OFF	ON	ON	ON	ON	ON	Normal	> 21.5V	Supply 1 defective 2), 4)	Sufficient power
ON	ON	ON	OFF	ON	ON	FI_3	Normal	16 ... 20.5		Modules still operate, but send a message "voltage low"
ON	ON	ON	OFF	ON	ON	OFF	OFF	< 16 V		Modules are inactive
ON	OFF	OFF	ON	ON	ON	ON	Normal	> 21.5V	Supply 1 not connected (AC 24 V) 2), 4)	sufficient power
ON	ON	OFF	OFF	ON	ON	FI_3	Normal	16 ... 20.5		Modules still operate, but send a message "voltage low"
ON	ON	OFF	OFF	ON	ON	OFF	OFF	< 16 V		Modules are inactive
ON	ON	OFF	ON	ON	ON	FI_3	I/O LED FI_3	> 21.5V	U10, Y10: AC/DC 24 V field supply not available on the module 4)	Affected module not receiving AC 24 V field supply from supply 1 because fuse is blown, but supply DC 24 V is operating
ON	ON	ON	ON	ON	ON	FI_3	I/O LED FI_3	< 20.5V	I420, I25: DC 24 V- supply is insufficient 4)	DC 24 V supply insufficient, overloaded, or too much load on DC 24 V outputs (>200 mA per module) 2), 4)

### 1) Assumption: PS2 is OK in all cases

#### 2) DC 24 V LED

- Flashing patterns FI\_x see 9.4.2
- Power supply module see 9.2
- Module status LED:
 

ON	DC 24 V > 21.5V	Power-up behavior	(hysteresis 20.5 ... 21.5 V)
FI_3	DC 24V = 16 ... 20.5 V	Behavior on power-down / overload	<b>4)</b>
OFF	DC 24 V < 16V	Behavior on power-down / overload	(hysteresis 16 ... 21.5 V)

#### 3) AS Fault LED

ON when fault message received from one module via bus AND AC 24 V available in AS

Note If the AS identifies an error (Fault LED ON), the affected I/O modules are disabled.

#### 4) Fault message on bus

The module transmits a fault message via island bus in the following cases:

- when **DC 24 V** drops below 20.5 V, monitored by the module (*but not when DC 24 V exceeds 27 V*)
- missing field supply **AC/DC 24 V** for U10, Y10 (monitored by the I/O points)
- missing field supply **DC 24 V** for I420, I25 (monitored by the I/O points)

## 9.6 Diagnostics based on the LED indicators – Integration via P-Bus BIM

Faults and information, based on the example of an I/O island with one P-Bus BIM and two power supply modules (Supply 1 and 2)

DISPLAY											FAULT / INFORMATION	DETAILS
P-Bus BIM				Supply 1		Supply 2 1)		Modules 4)		DC24V from bus 2)		
RUN LED	FAULT LED 3)	AC24V LED	DC24V LED 2)	AC24V LED	DC24V LED 2)	AC24V LED 1)	DC24V LED 2)	Module status LED 2)	Other LEDs	DC24V from bus 2)		
<b>A) Operation, configuration, communication etc.</b>												
ON	OFF			ON				ON	Normal	> 21.5V	No fault	Normal operation
ON	OFF			ON				ON	OVR LED ON	> 21.5V	No fault	Local override ON
ON	OFF			ON				FI_4	Normal	> 21.5V	No fault	Tool override on at least one I/O point of the module is
ON	FI_5			ON				ON	Normal	> 21.5V	No fault	Configuration, island bus report (indication throughout process)
ON	OFF			ON				FI_3	I/O LED FI_3	> 21.5V	Invalid signal (e.g. short circuit or open circuit)	<ul style="list-style-type: none"> <li>Synchronous flashing</li> <li>Details on LCD panel, if any (see page 60)</li> </ul>
ON	OFF			ON				ON	OVR LED FI_6	> 21.5V	Illegal operation	e.g. attempt to operate an input or an output where local override is not activated
ON	OFF			ON				ON	OVR LED FI_8	> 21.5V	Illegal operation	e.g. attempt to operate an input or an output where local override is disabled (configuration)
ON	OFF			ON				FI_3	Normal	> 21.5V	Faults that are not in relation to an I/O point	<ul style="list-style-type: none"> <li>Address key inserted</li> <li>All module related faults</li> </ul>
ON	ON			ON				OFF	All OFF	> 21.5V	Module in parked position	Module inactive
ON	FI_3			ON				FI_3	Normal	> 21.5V	No configuration	All modules have Default functions
ON	ON			ON				ON	Normal	> 21.5V	Configuration error	<ul style="list-style-type: none"> <li>At least one module has incorrect configuration</li> <li>Multiple module addresses or permutations, etc.</li> </ul>
ON	ON			ON				FI_1	All OFF	> 21.5V	No address key and not configured	<ul style="list-style-type: none"> <li>At least one module unconfigured = BIM Fault LED ON (Module configured = at least 1 I/O point configured)</li> <li>If unconfigured channels not used by application: No fault (BIM Fault LED OFF; module status LED and I/O Status LEDs do not flash)</li> </ul>
ON	ON			ON				FI_2	All OFF	> 21.5V	No address key and configured	At least 1 I/O point is configured
ON	ON			ON				FI_3	Normal	> 21.5V	<ul style="list-style-type: none"> <li>Address key inserted</li> <li>Not configured</li> <li>Communications error</li> <li>EMC fault</li> </ul>	Examples of communication errors: <ul style="list-style-type: none"> <li>Bus not connected</li> <li>Bus short-circuit</li> <li>Voltage drop on bus cables is too high</li> </ul>
<b>B) Power supply</b>												

DISPLAY											FAULT / INFORMATION	DETAILS
RUN LED	P-Bus BIM			Supply 1		Supply 2 1)		Modules 4)		DC24V from bus 2)		
	FAULT LED 3)	AC24V LED	DC24V LED 2)	AC24V LED	DC24V LED 2)	AC24V LED 1)	DC24V LED 2)	Module status LED 2)	Other LEDs			
ON	OFF	ON	ON	ON	ON	ON	ON	ON	Normal	> 21.5V	Normal operation	An eventually defective supply in BIM or power supply module is not recognized as long as DC 24 V > 21.5 V
ON	ON	ON	ON	ON	ON	ON	ON	FI_3	Normal	16 ... 20.5	Supply overloaded 2), 4)	Modules still operate, but send a message "voltage low"
ON	ON	ON	ON	ON	ON	ON	ON	OFF	OFF	< 16 V		Modules are inactive
OFF	OFF	OFF	OFF	ON	ON	ON	ON	FI_3	Normal	> 21.5V	BIM not connected (AC 24 V) 2)	No communication, sufficient power
OFF	OFF	OFF	OFF	ON	ON	ON	ON	FI_3	Normal	16 ... 20.5		No communication, insufficient power
OFF	OFF	OFF	OFF	ON	ON	ON	ON	OFF	OFF	< 16 V		Modules are inactive
OFF	OFF	ON	ON	ON	ON	ON	ON	ON	Normal	> 21.5V	Supply 1 defective 2), 4)	sufficient power
ON	ON	ON	ON	ON	OFF	ON	ON	FI_3	Normal	16 ... 20.5		Modules still operate, but send a message "voltage low"
ON	ON	ON	ON	ON	OFF	ON	ON	OFF	OFF	< 16 V		Modules are inactive
ON	OFF	ON	ON	OFF	ON	ON	ON	ON	Normal	> 21.5V	Supply 1 not connected (AC 24 V) 2, 4)	sufficient power
ON	ON	ON	ON	OFF	OFF	ON	ON	FI_3	Normal	16 ... 20.5		Modules still operate, but send a message "voltage low"
ON	ON	ON	ON	OFF	OFF	ON	ON	OFF	OFF	< 16 V		Modules are inactive
ON	ON	ON	ON	OFF	ON	ON	ON	FI_3	I/O LED FI_3	> 21.5V	U10, Y10: AC/DC 24 V field supply not available on the module 4)	Affected module not receiving AC 24 V field supply from supply 1 because fuse is blown, but supply DC 24 V is operating
ON	ON	ON	ON	ON	ON	ON	ON	FI_3	I/O LED FI_3	< 20.5V	I420, I25: DC 24 V- supply is insufficient 4)	DC 24 V supply insufficient, overloaded, or too much load on DC 24 V outputs (>200 mA per module) 2), 4)

### 1) Assumption: PS2 is OK in all cases

### 2) DC 24 V LED

- Flashing patterns FI\_x see 9.4.2
- BIM, Power supply module see 9.2
- Module status LED:
 

ON	DC 24 V > 21.5V	Power-up behavior	(hysteresis 20.5 ... 21.5 V)
FI_3	DC 24V = 16 ... 20.5 V	Behavior on power-down / overload	<b>4)</b>
OFF	DC 24 V < 16V	Behavior on power-down / overload	(hysteresis 16 ... 21.5 V)

### 3) BIM Fault LED

ON when fault message received from one module via bus AND AC 24 V available in BIM

Note If the BIM identifies an error (Fault LED ON), the affected I/O modules are disabled.

### 4) Fault message on bus

- The module transmits a fault message via island bus in the following cases:
- when **DC 24 V** drops below 20.5 V, monitored by the module (*but not when DC 24 V exceeds 27 V*)
  - missing field supply **AC/DC 24 V** for U10, Y10 (monitored by the I/O points)
  - missing field supply **DC 24 V** for I420, I25 (monitored by the I/O points)

## 9.7 Diagnostics on the PROFINET BIM



LED-indication		Description
<b>RUN</b>	<b>FLT</b>	<b>Cause</b>
on	off	Firmware runs correctly
on	blinking	Alarm exists
on	on	Firmware runs, no PROFINET communications
blinking	blinking	Hardware problem
blinking	off	Firmware update running, firmware operating
blinking	on	Firmware update running, firmware operating
off	on	Firmware not operating

LED-indication				Description
<b>LINK1</b>	<b>COM1</b>	<b>LINK2</b>	<b>COM2</b>	<b>Cause</b>
on	on			Connection on Ethernet-Port 1 OK
		on	on	Connection on Ethernet-Port 2 OK
	flickering			Ethernet-communications Port 1
			flickering	Ethernet-communications Port 2

For more information see document CM110564, TX-I/O PROFINET BIM V1.0 – User's guide.

# 10 Principles of electrical design

## 10.1 Definitions

---

Cable materials and cable routing: see Section 6.4 and 6.6.

Wiring examples: see Section 6.4.2.

From an electrical perspective a distinction can be made between the following elements:

### Island bus signal

The island bus signal is based on the CD (Communication Data), CS (Communication Supply) and system neutral ( $\perp$ ) conductors. It reaches the I/O row in one of two ways:

- From a **bus interface module** via the **bus connector** at the beginning of the I/O row
- From a remote bus interface module (on another I/O row or in another control panel) via a **cable** connected to a **bus connection module or power supply module** at the beginning of the I/O row.

### Module power supply

The DC 24 V module power supply incorporates the system neutral ( $\perp$ ) and Communication Supply (CS) conductors. This provides the TX-I/O modules with the operating voltage.

In some cases, it also provides the field device supply (e.g. for active sensors).

The module supply reaches the I/O row in one of three ways:

- From a **bus interface module** at the beginning of the I/O row, via the **bus connector**
- From a **power supply module**, via the **bus connector**
- From a remote bus interface module or power supply module (on another I/O row or in another control panel) via a **cable** connected to a **bus connection module**.

Within a given I/O row or I/O island, an **additional power supply module** is required as soon as the maximum power from the initial supply (1.2 A) is "used up".

To determine whether a second power supply module is needed, simply add together the individual values from the tables further below (10.8 "Consumption data DC 24 V") and the consumption of the DC 24 V field devices.

### Parallel connection of module supply units

Devices with a DC 24 V module supply (power supply modules and bus interface modules) can be operated in parallel if the power requirements make this necessary.

**Up to 4** power supply modules may be connected in parallel **per I/O island**, with **up to 2** for **each I/O row**.

**Island bus expansion:** for each decentralized sub-island again up to 4 parallel power supply modules, with up to 2 for each I/O row.



### Note!

#### Power supply DC 24 V for modules using a 3rd-party device:

An external power supply is connected via a TXS1.EF10 bus connection module.

- No parallel operation admitted.
- Separate fuse for each TXS1.EF10 bus connection module: max. 6 A.

## Field device supply

For field devices requiring a supply other than DC 24 V, the bus includes a separate conductor (24V~ / V $\approx$ ). The return is via  $\perp$  (system neutral).

The admissible current is max. 6 A.

This conductor can be supplied in one of two ways:

- with **AC 24 V** from a **bus interface module** or a **power supply module**.

This voltage is protected in the bus interface module / power supply module by a 10 A fine-wire fuse.

- with **AC / DC 12 ... 24 V** from a **bus connection module**.

This voltage is protected in the bus connection module by a 10 A fine-wire fuse.

The 24V~ conductor (power supply module) / V $\approx$  (bus connection module) is only accessible on the bus connector to the right; it does not exist on the left side. This means that within the same I/O row, several groups of modules can be formed, each with a different field device supply, without having to interrupt the remaining bus conductors (bus signal CD and module supply CS).

On a given I/O row, a **new field device supply** is required

- when the maximum power of the original field device supply (6 A) is reached, and
- whenever a group of I/O modules requires a different voltage or its own fuse.

## 10.2 Voltage and current limits

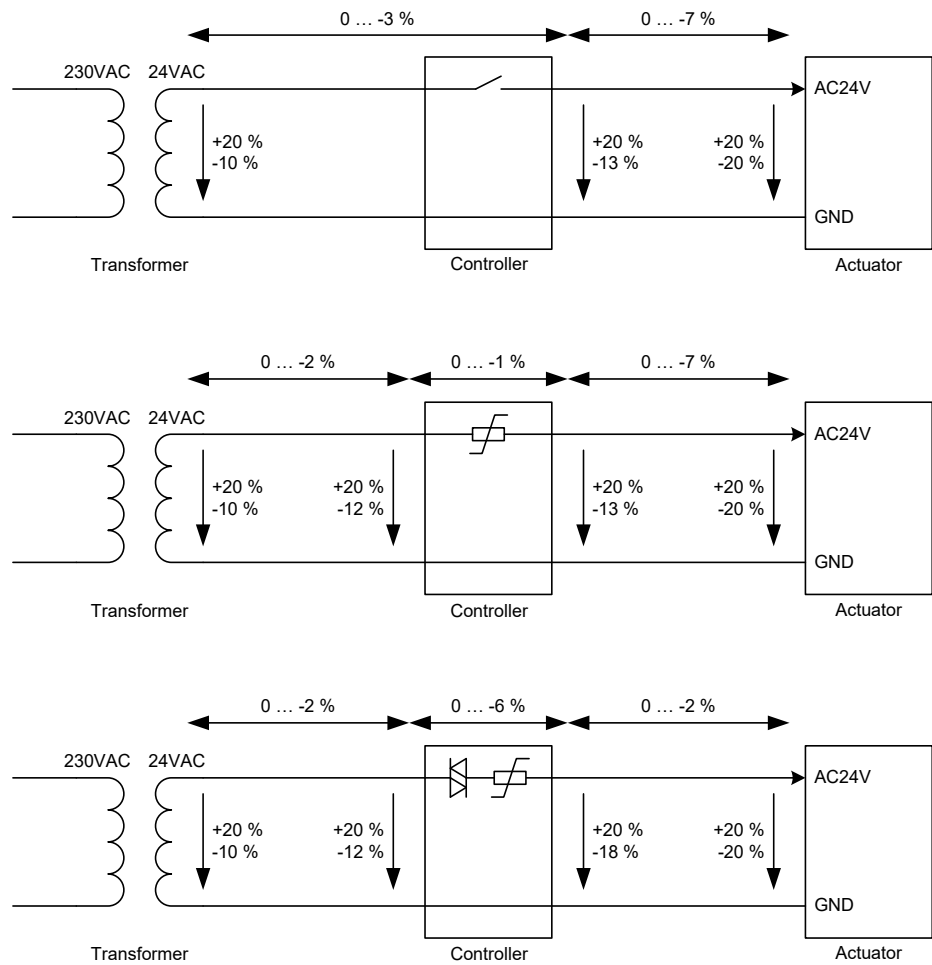

### Admissible voltage drop, field supply AC 24 V

In the system, the admissible deviation from the nominal voltage of AC 24 V is  $\pm 20\%$ . The maximum admissible voltage drop of  $-20\%$  for the field devices is made up as follows:

1. Fluctuations in nominal voltage:  $-10\% = -2.4 \text{ V AC}$
2. Supply cable between transformer and power supply inlet (BIM, power supply module, bus connection module):  $-2\% = -0.48 \text{ V AC}$
3. Contact resistances of bus connectors on a given I/O row:  $-1\% = -0.24 \text{ V AC}$
4. Connecting cables between I/O modules and field devices:  $-7\% = -1.68 \text{ V AC}$

### Admissible voltage drop, field devices connected to triacs (TXM1.8T)

Connecting cables between I/O modules and field devices:  $-2\% = -0.48 \text{ V AC}$   
(The triac with its protecting devices has already 6% voltage drop).

10562178

**Admissible voltage, module supply DC 24 V**

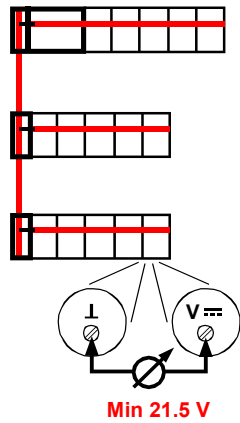

In order to run correctly, the TX-I/O modules require a supply voltage (CS) above DC 21.5 V. This voltage can be measured on the terminals of a TXM1.8X module that lies in the I/O row most distant from the power supply.

**Admissible voltage difference, module supply**

The module supply voltage CS must not deviate by more than 0.5 V between any 2 points of an I/O island (refer also to Section 6.4.2 "Wiring examples"). Reason: CS is the reference voltage for the bus signal. If CS deviates by more than 0.5 V, bus communications do not work any more.

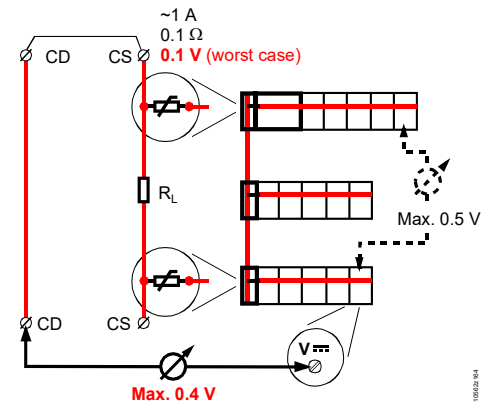
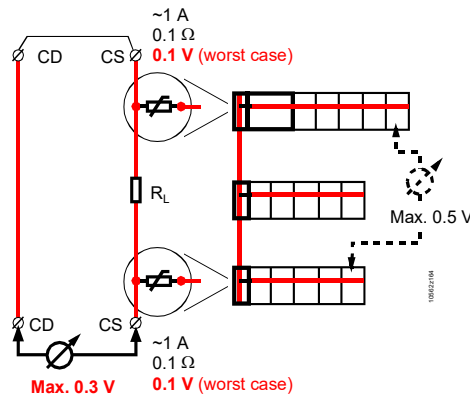
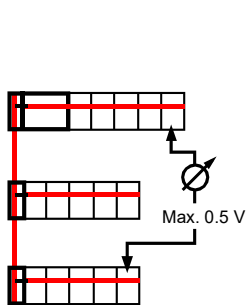

Theory

Practical measuring # 1

Practical measuring # 2

- Short the conductors CS and CD on the power supply module / P-Bus-BIM
- While there is no current on CD, the supply current on CS causes a voltage drop over the line resistance  $R_L$

**Max. current**

- When feeding the module supply (CS) from one I/O row to another I/O row, max. 1.2 A is permissible. Any higher current is blocked by a PTC resistor in the supply module and in the bus connection module.
- The current rating for the AC/DC field device supply must not exceed 6 A. Reason: Voltage drop and heat dissipation on the bus connectors.
- Max. current rating for field supply **per module**:
  - DC 24 V: 200 mA per module  
Any higher current is blocked by a PTC resistor in the module.
  - AC/DC 12 ... 24 V: 4 A per module
- Max current for **relay contacts**: see contact data on page 117.

**Limits in Simatic**

See PROFINET BIM User's manual [9]

## 10.3 Admissible number of devices

---

### Module power supply TXS1.12F10 or TXB1.PBUS or PXC3...

- Parallel operation: max. 4 power supply units per I/O island.
- Parallel operation: max. 2 power supply units per I/O row  
Reason: max. current in the I/O row in case of a short-circuit.
- Island bus expansion: for each decentralized sub-island again up to 4 parallel power supply modules, with up to 2 for each I/O row.

### Module power supply 3rd-party device DC 24 V

- An external power supply is connected via a TXS1.EF10 bus connection module.
- No parallel operation admitted
  - Separate fuse for each TXS1.EF10 bus connection module: max.6 A.

### Bus connection modules

- **Max. 16 bus connection points**, e.g. 1 bus interface module + 3 supply modules + 12 bus connection modules)  
Reason: with more bus participants, bus communications do not work anymore  
→ This means that the number of I/O rows in an I/O island is limited to 16.

### I/O row

- Max. length of one I/O row: 1.6 m (equivalent to **25 I/O modules, 512 data points**)  
Reason: To avoid a drop in the field supply voltage owing to the contact resistance at the bus connectors.

### I/O island

- The maximum number of **subscribers on the island bus is 64**.  
Reason: performance of the island bus.  
This can be achieved, by a maximum of 16 rows of 4 modules, for example, or by four rows of 16 modules.

### Limits for island bus expansion

Number of decentralized sub-islands per I/O island	Max. 8
Number of island bus expansion modules per decentralized sub-island	Exactly 1
Number of I/O modules per I/O island	Maximum of 64
Number of I/O modules per sub-island	No limit, as long as the total of the entire island (64) is maintained.

### Limits in Simatic

See PROFINET BIM User's manual [9]

## 10.4 Cables for AC 24 V

This section concerns the cables between transformer and power supply inlet (BIM, power supply module, bus connection module, see Section 6.4).

Installation example:  
Designo

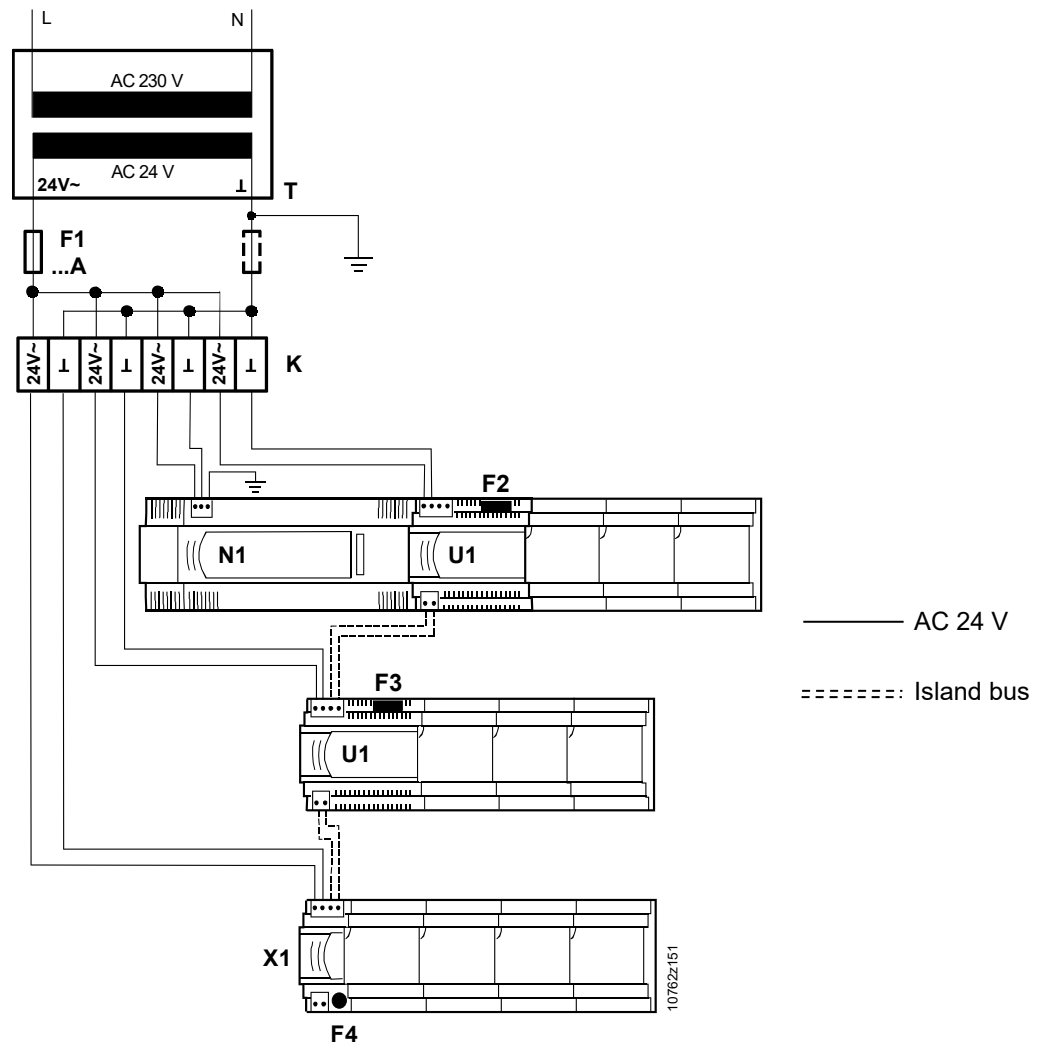

### Calculation basis

AC 24 V is always connected in a star configuration (see the wiring examples 6.4.1).

The calculations are based on the voltage drop value (0.6 V) referred to in Section 10.2 for the supply cable between transformer and power supply inlet (bus interface module, power supply module, bus connection module).

## Power consumption

The power consumption of the devices is as follows:

Power consumption (individual items)	Device	Room-automation station PXC3...	Power supply module TXS1.12F10	Bus connection module TXS1.EF10	P-Bus interface module TXB1.PBUS
Without module and field device load		8 VA / 0.33 A	4 VA / 0.17 A	--	7.5 VA / 0.31 A
<b>Island bus</b> at maximum admissible load DC 24 V / <b>1.2 A</b>		--	53 VA / 2.4 A	--	47 VA / 2.3 A
<b>Island bus</b> at maximum admissible load DC 24 V / <b>0.6 A</b>		30 VA / 1.25 A	--	--	--
<b>PL-Link</b> at maximum admissible load DC 29 V / 160 mA		12 VA / 0.50 A			
<b>DALI</b> at maximum admissible load DC 16 V / 128 mA		9 VA / 0.37 A			
<b>Pass-through</b>					
AC 24 V / 6 A (Island bus)		144 VA / 6.0 A	144 VA / 6.0 A	144 VA / 6.0 A	144 VA / 6.0 A
AC 24 V / 2 A (terminals 3 and 4)		48 VA / 2.0 A			
AC 24 V / 6 A (terminals 7 and 8, for additional AC 24 V devices)		144 VA / 6.0 A *)			
<b>Admissible sum</b>		<b>240 VA / 10 A *)</b>	<b>200 VA / 8.4 A</b>	<b>144 VA / 6A</b>	<b>200 VA / 8.3 A</b>

\*) Only to the extent that the admissible current of 10 A at the AC 24 input terminals 5 and 6 is not exceeded.

## Load-dependent cable lengths

The permissible voltage drop of 0.48 V (2%) on the power wire between the transformer and the most distant power point (Controller, power supply module, bus connection module) is the basis for calculations.

The table below provides cable lengths and cable cross sections based on load.

Cable cross-section Power	Cable length					
	10 VA	10 VA	20 VA	50 VA	100 VA	200 VA
<b>2.50 mm<sup>2</sup> / AWG14</b>	135 m 440 ft	70 m 220 ft	35 m 110 ft	13 m 44 ft	7 m 22 ft	3 m 11 ft
<b>1.50 mm<sup>2</sup> / AWG16</b>	85 m 280 ft	42 m 140 ft	21 m 70 ft	8 m 30 ft	4 m 15 ft	2 m 7 ft
<b>1.00 mm<sup>2</sup> / AWG16</b>	55 m 180 ft	27 m 90 ft	13 m 45 ft	5 m 17 ft	3 m 9 ft	1 m 4 ft

- Notes
- The outgoing (AC24 V) and return (⊥) cables may **each** have the indicated length.
  - Each connection point (Controller, supply module, bus connection module) must be connected separately to the terminal block of the transformer (star configuration).
  - Conductors may be wired in parallel as a means of increasing the cross-section.
  - **In practice, the small admissible voltage drop means that the transformer must always be placed close to the consumer load.**

## 10.5 Cables for the island bus (DC 24 V)

A critical factor when planning the layout of remote sub-islands is the admissible length of the island bus cables.

In the case of the **AC 24 V supply voltage**, long distances are easy to overcome by ensuring that the sub-island has its own transformer (see the wiring diagrams in Section 6.5).

With the **island bus**, however, the cable length is limited by capacitance and by voltage drop.

### Limiting factors

- The **total capacitance** of all cable sections in an I/O island must not exceed 4.0 nF.
  - All sections must be added together.

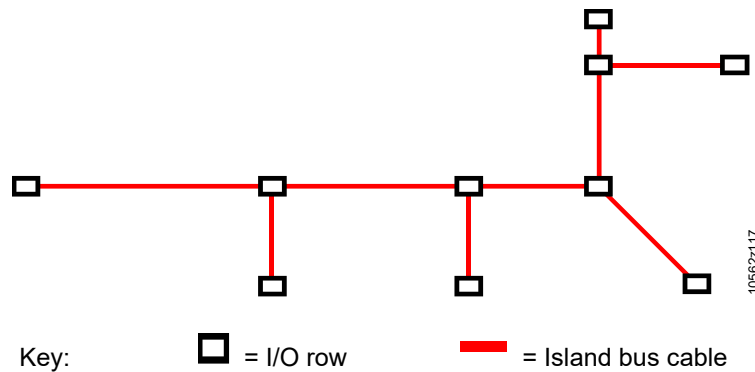

- The **voltage difference** between any two points on the island bus conductor CS must not exceed 0.5 V (Section 10.2).
  - The cable length between the most distant points of the island counts.
  - The voltage drop occurs mainly in the **bus cables** between the I/O rows or sub-islands.
  - The return route for the supply current is via system neutral ( $\perp$ ).
  - The bus signal currents on conductor CD are negligible.

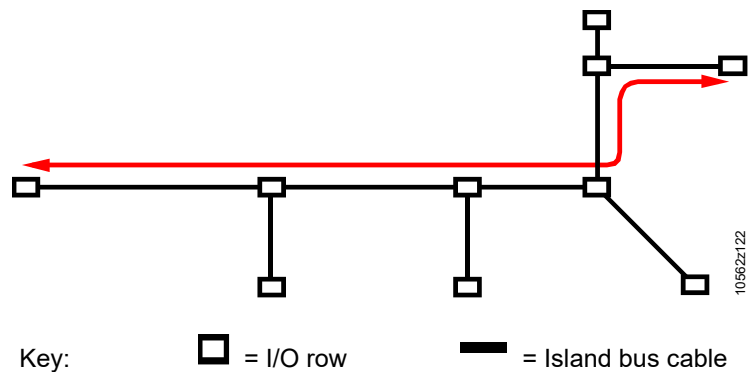

## Cable material

- **Two- or three-core round cable**, insulated for 300 V or higher (control cables, sensor cables, power cables, field bus cables, etc.)  
Examples: Harmonized cable in accordance with CENELEC HD 361 52: H05VV-F (stranded) or H05VV-U (solid wire).  
**Round cables MUST NOT be wired in parallel** as a means of increasing the cross-section. Otherwise the capacitance between CS and CD would increase.
- **Coaxial cable** with braided screen  
Example: Type RG-62 (Specific capacitance 43 nF / km)  
The higher currents travel via the CS conductor rather than the CD conductor. CS must therefore be connected to the cable shield (the shield of a coaxial cable has a higher cross-section than the core).
- **Parallel wiring** of the shield of a coaxial cable with one SINGLE conductor. This increases the cross section of CS without increasing the capacitance.
- To avoid loops (inductive interference), the **cables must be tied together**.

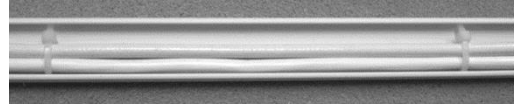

**Admissible cable combinations**

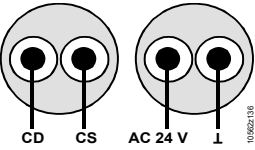
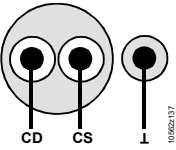
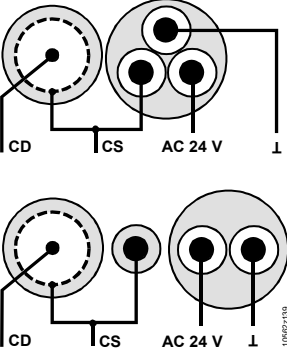
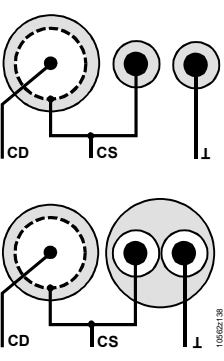
	<b>AC24 V: 1 transformer</b> (AC 24 V must be fed from one sub-island to the other)	<b>AC 24 V: 2 transformers</b> (AC 24 V is supplied separately for each sub-island)
<b>A) Round cables:</b> → up to 50 m admissible		
<b>B) Coaxial cable and round cables</b> → up to 100 m admissible		

Example

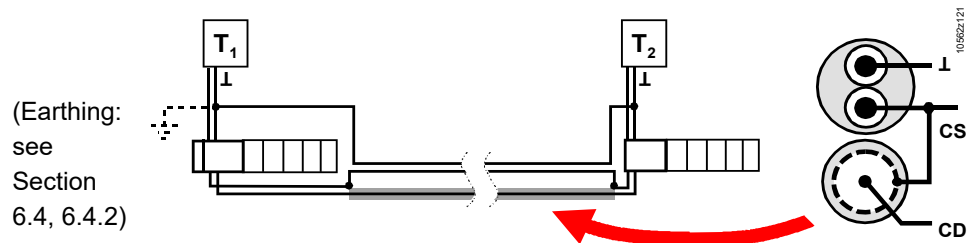

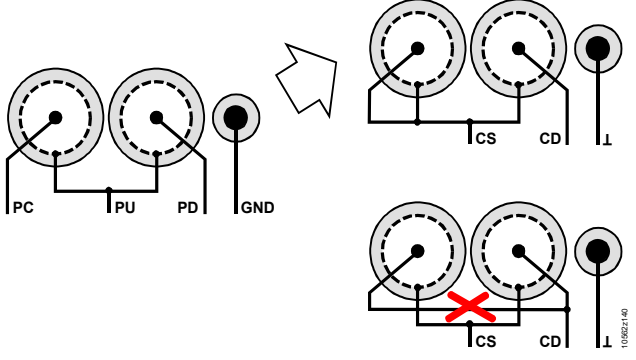
	<b>AC24 V: 1 transformer</b> (AC 24 V must be fed from one sub-island to the other)
<b>C) 2 coaxial cables</b> (e.g. existing system with remote P-bus) → up to 75 m admissible	 <p><b>Forbidden</b> (capacitance too high) ↗</p>

## 10.5.1 Max. cable lengths for island bus

### Estimation of capacitance

Capacitance of two-core cables depends on the following (with decreasing importance)

- Material (dielectrical constant  $\epsilon_r$ ), the lower the better, **values below 4.5 are OK**
- Insulation thickness  $b$  (the thicker the better)
- conductor's diameter  $a$  (the thinner the better)

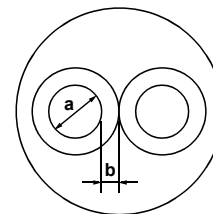

dielectrical constant values

Material	$\epsilon_r$
PVC	4 ... 4.5
Polyethylene	2.4
Silicon	3.2
TPE (PETP)	3.3
Teflon	2.1
Nylon	3.5

### Max. cable lengths

Cable type	Insulation thickness $b$	Resulting specific capacitance	Max. length $L_{max}$ for island bus
<b>A) Round cable</b>			
<b>AWG16</b> <b>1.5 mm<sup>2</sup></b>	$\geq 0.6$ mm	$< 100$ nF/km	<b>30 m</b>
<b>AWG14</b> <b>2.5 mm<sup>2</sup></b>	$\geq 0.9$ mm	$< 80$ nF/km	<b>50 m</b>

Cable type	Specific capacitance required for coax. cable	Max. length $L_{max}$ for island bus
<b>B) Coaxial cable *)</b>		
– parallel to <b>AWG16</b>	$< 65$ nF/km	<b>70 m</b>
– parallel to <b>1.5 mm<sup>2</sup></b>	$< 60$ nF/km	<b>75 m</b>
– parallel to <b>AWG14</b>	$< 50$ nF/km	<b>90 m</b>
– parallel to <b>2.5 mm<sup>2</sup></b>	$< 45$ nF/km	<b>100 m</b>
<b>C) Coaxial cable parallel to coaxial cable</b>	$< 60$ nF/km Spec. resistance shield: $< 11$ $\Omega$ /km	<b>75 m</b>

\*) **Coaxial cable:** Thanks to better high frequency features, approx. 10% longer cables than with round cable are admissible.

The CS conductor carries the highest loads. Therefore the current must be routed via the cable shield (the shield of a coaxial cable has a higher cross-section than the core).

The above values are based on an RG62 cable with a specific shield resistance of 11  $\Omega$ /km for the shield. For other cables, the max. length must be adapted accordingly.

Coaxial cable types (examples):

Coaxial cable	Spec. capacitance	Spec. resistance (shield)
RG62, diameter 6mm	43 nF/km	11 $\Omega$ /km
RG59	67 nF/km	7.8 $\Omega$ /km
TALASS BGAL C100	56 nF/km	18 $\Omega$ /km

## 10.5.2 Installation rules for island bus

### Glossary for the Topologies

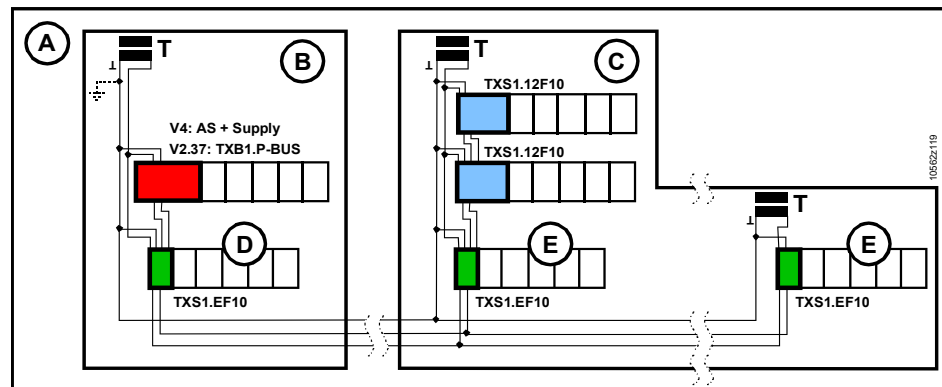

- Key
- A** I/O island, consisting of sub-islands **B** and **C**.
  - B** Local sub-island with a local I/O row **D**.
  - C** Remote sub-island with remote I/O rows **E**.
  - T** In general, a sub-island or remote I/O row needs its **own transformer**, as only short cables are admissible at high AC 24 V loads (see Section 10.4). See also the wiring examples and earthing hints in Section 6.4.2.

### Rules concerning the topology

1. The topology is free (line or star topology, but NOT ring topology)
2. One I/O island may include 1 ... 4 supplies (P-Bus-BIM, power supply module).
3. One I/O island may include 1 ... 4 sub-islands.
4. One sub-island may include 1 ... 4 local supplies.
5. One sub-island may include 1 ... 12 local or remote I/O rows, each with a bus connection module TXS1.EF10.
6. Each sub-island must include sufficient power supply modules to avoid having to draw current from another sub-island (at maximum load of the connected I/O modules).  
In other words: A sub-island must have no remote supplies, only local supplies.
7. A remote sub-island normally requires its own transformer for AC 24 V.  
***If this transformer is switched off, the supplies of the other sub-islands will try to deliver DC 24 V into this sub-island. The resulting current causes an additional voltage drop, which will disturb island bus communications.***

### Rules concerning the examples below

8. The examples on the following pages do not include transformers, but the following elements:
  - Automation station + power supply module TXS1.12F10 ■,
  - **P-Bus-BIM** Bus Interface modules TXB1.P-BUS ■,
  - **PROFINET-BIM** + power supply module TXS1.12F10 ■,
  - Power supply modules TXS1.12F10 ■,
  - Bus connection modules TXS1.EF10 ■, and
  - I/O modules .
9. For the values of the admissible length  $L_{max}$  refer to Section 10.5.1.
10. The admissible current is higher if you accept shorter distances in proportion up to the max. power of 1.2 A per supply).
11. The admissible cable length is higher if you accept lower currents in proportion (up to the admissible length  $L_{max}$ ).
12. The admissible current of remote I/O rows can be increased by placing the supply in the "center" of the group of I/O rows rather than at one end of the group.

### 10.5.2.1 Examples without any remote supplies

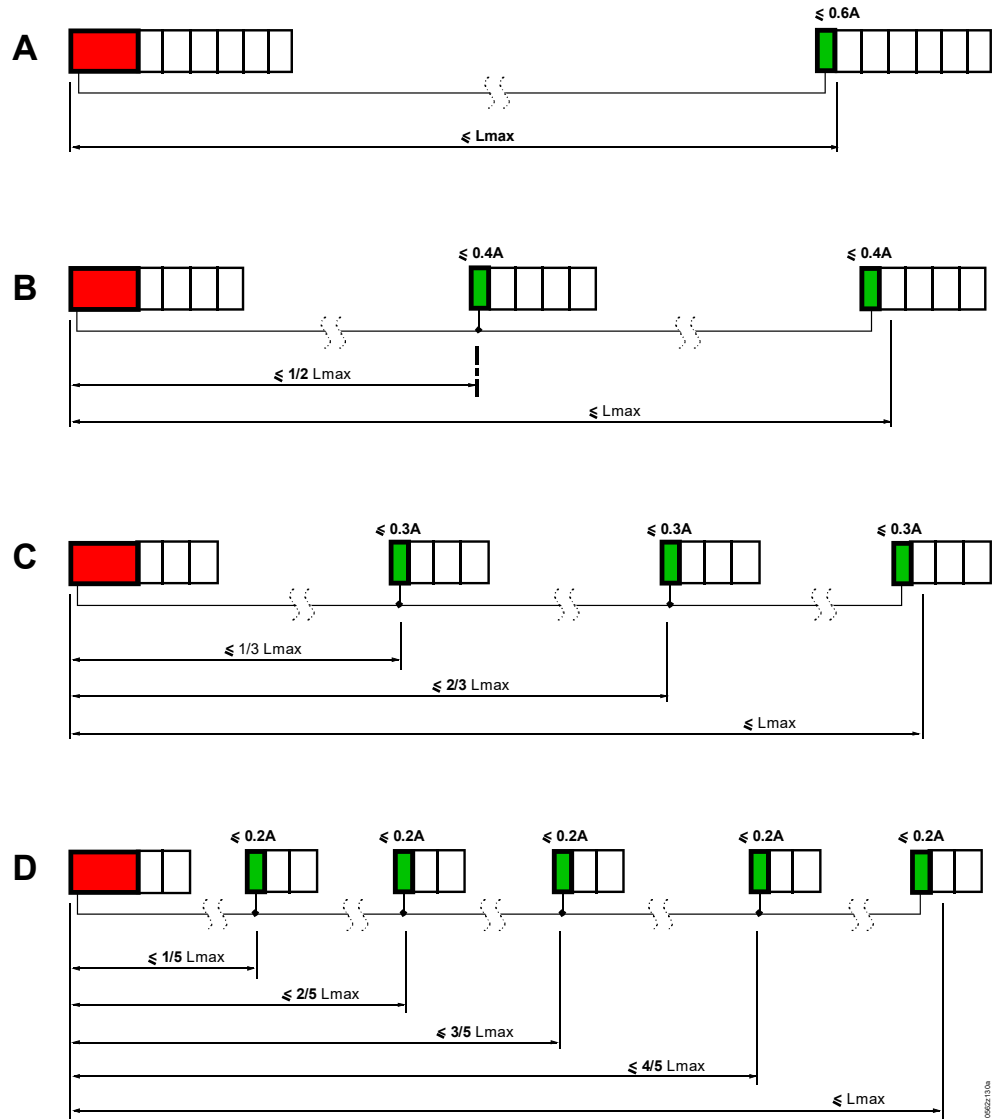

- Notes
- The sum of all island bus cable segments must not exceed  $L_{max}$  (see 10.5.1).
  - The above examples show that the sum of the admissible currents for the remote I/O rows increases with the number of I/O rows, because a decreasing part of the current flows over the entire cable length.
  - If higher currents are required, the cable lengths must be reduced proportionally (see example E below with twice the current and half the length compared to example C).

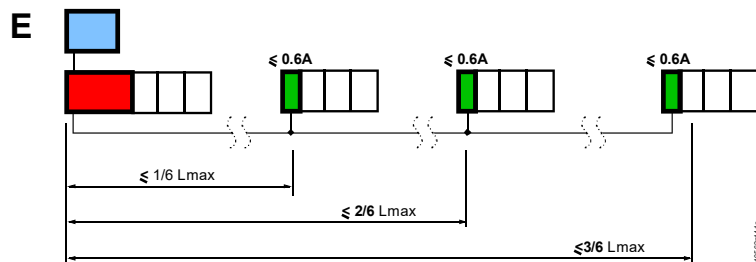

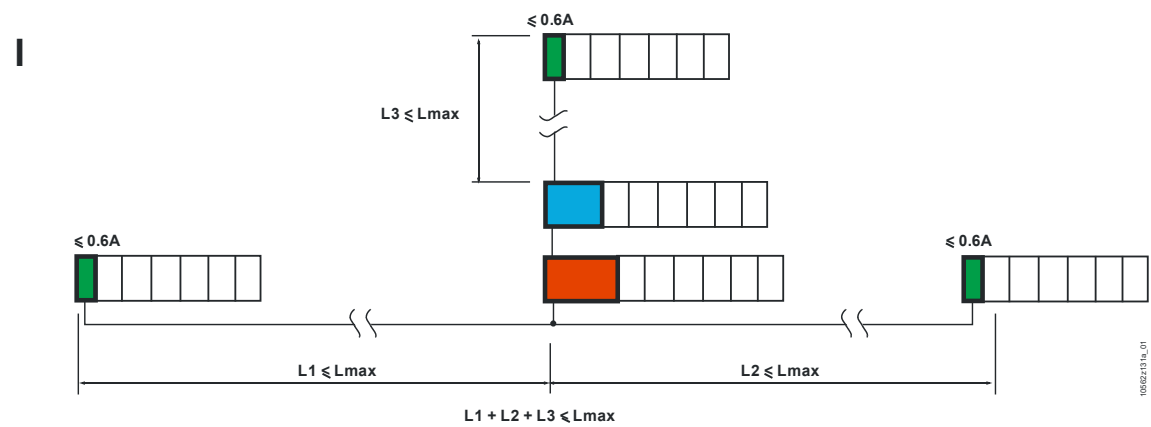
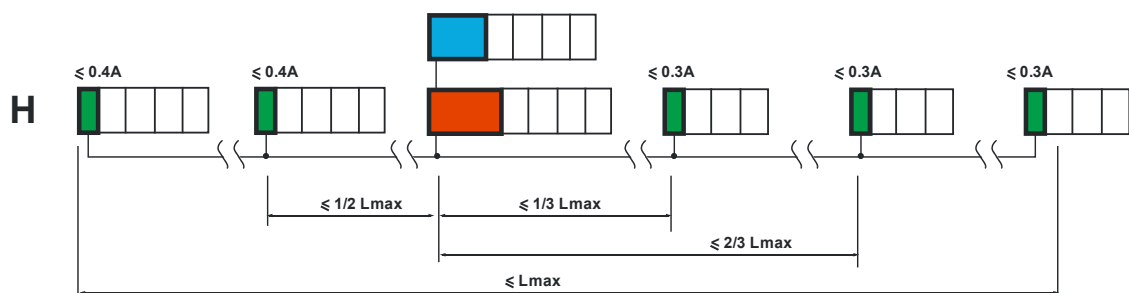
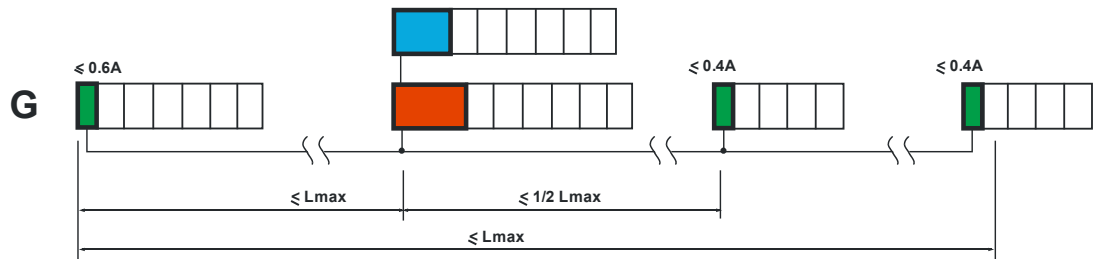
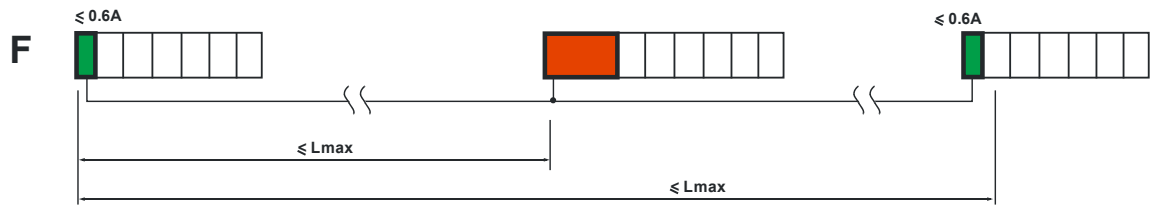

- Notes
- If high currents are required in the remote I/O rows, the supply should be placed in the "center" of the sub-island.
  - If the total current exceeds 1.2 A, a multiple supply is required (see 10.5.2.4).

### 10.5.2.2 Examples with 2 remote supplies (2 sub-islands)

K

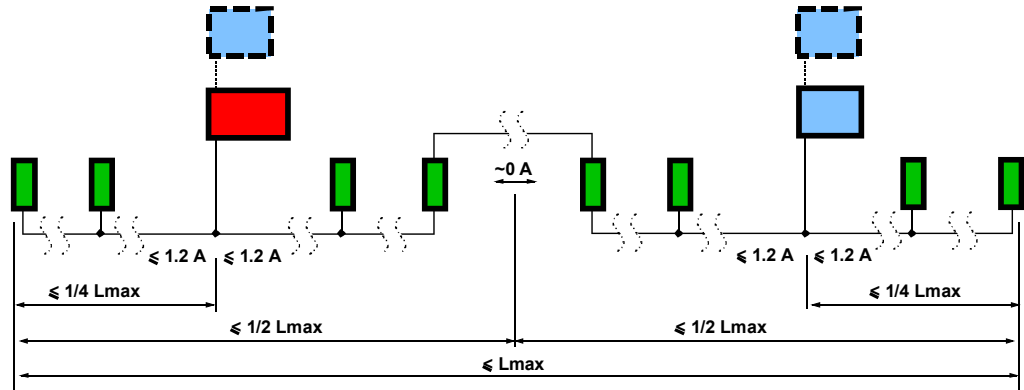

L

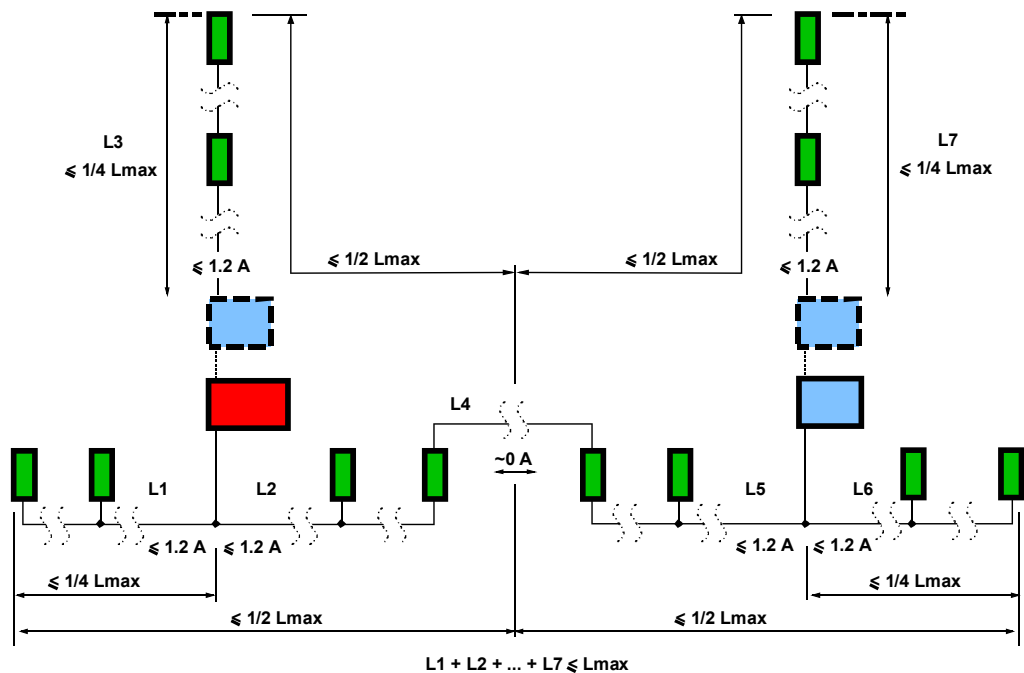

- Notes
- The sum of all island bus cable segments must not exceed  $L_{max}$  (see 10.5.1).
  - Each sub-island must include sufficient power supply modules to avoid having to draw current from another sub-island (at maximum load of the connected I/O modules).
  - The current values are higher than in 10.5.2.1 (examples A-D), because the length of the bus cable in each sub-island is only  $1/2 L_{max}$ .
  - The above examples show that each I/O row (or group of I/O rows) may consume the entire admissible current, if it is connected directly to the supply (the value of 1.2 A is not related to the admissible load of the supply but to the admissible voltage drop in the bus cable).
  - If high currents are required in the remote I/O rows, it is preferable to place the supply in the "center" of the sub-island.

106/02133A

### 10.5.2.3 Examples with 4 remote supplies

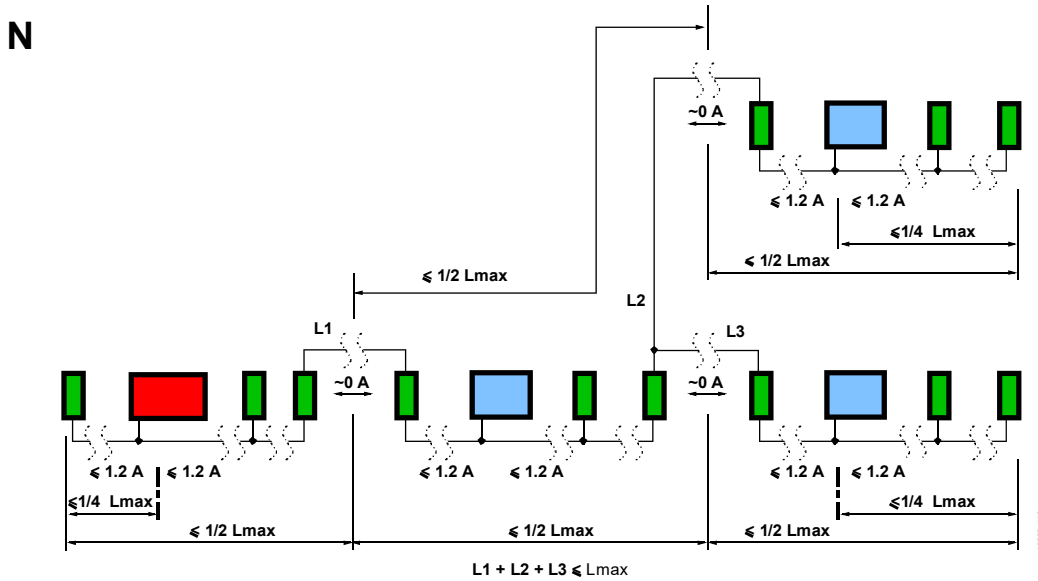
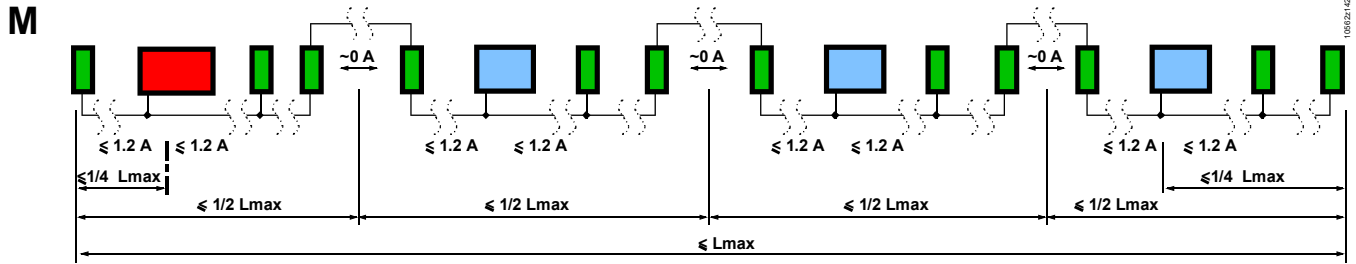

- Notes
- The sum of all island bus cable segments must not exceed  $L_{max}$  (see 10.5.1).
  - None of the sub-islands must draw current from another sub-island (at maximum load of the connected I/O modules).
  - Each sub-island is limited to 1.2 A (capacity of the supply / the bus interface module; no multiple supplies are admitted, as the island already includes the maximum of 4 supplies).
  - Both examples have the maximum number of 4 supplies and 12 I/O rows.
  - Example N shows that the topology is free (line or star, but NOT ring).

### 10.5.2.4 Multiple supplies

If currents higher than 1.2 A must flow out of an I/O row, a multiple supply is required. If two or more supplies together deliver current to an I/O row other than their own (be it local or remote), these supplies must themselves be placed in different I/O rows. They must be connected by a short cable via the screw terminals.

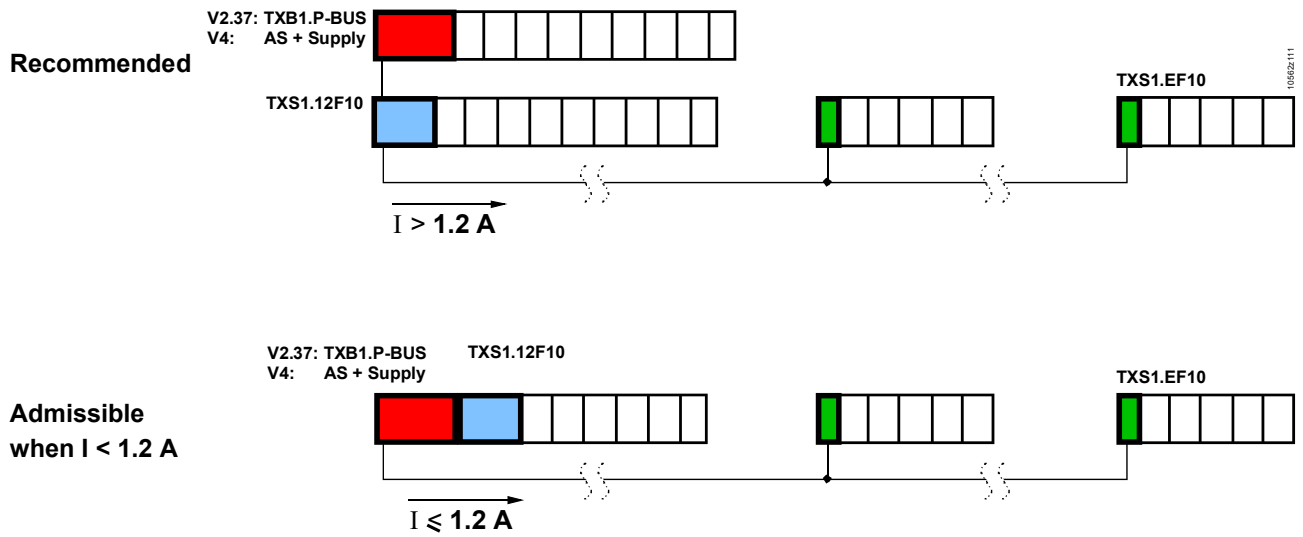

## 10.6 Island bus expansion

### 10.6.1 Benefits of island bus expansion

- The island bus expansion modules allow for “decentralized” sub-islands with TX-I/O-modules, that may be located up to 2 x 200 m from the "local" sub-island.
- The island bus expansion is based on differential RS-485 transmission technology.
- Programming / parameterization not required.
- The DIP switches for the bus manager and bus terminator must be set correctly on the island bus expansion modules.
- The island bus expansion is galvanically connected to the island bus (PTC protective resistance of the  $\nabla$  and  $\perp$  wires)
- The island bus expansion provides some protection against faults for sub-islands. Example: A failed transformer in a decentralized sub-island (power AC 24 V for power supply module), cannot result in a drop off of power (wire CS, DC 24 V) on other sub-islands.

### 10.6.2 Limits

Number of decentralized sub-islands per I/O island	Max. 8
Number of island bus expansion modules per sub-island	Exactly 1
Number of I/O modules per I/O island	Maximum of 64
Number of I/O modules per sub-island	No limit, as long as the total of the entire island (64) is maintained.

### 10.6.3 Restrictions

The island bus expansion operates as described here

- with TX-I/O modules for series C or higher only
- with P-Bus BIM series B or higher only
- with PXC-NRUD Series C and higher only (Migration – INTEGRAL AS1000)
- with all PROFINET BIM models

(see label packaging and device marking):

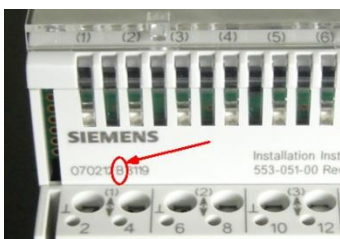

TX-I/O module

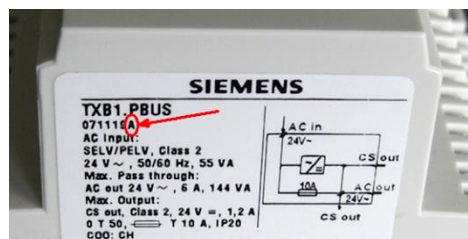

P-Bus-BIM TXB1.PBUS



PXC-NRUD

#### Note

You may operate modules from series B as well as P-Bus-BIM series A with the island bus expansion. The admissible length of the **island bus expansion** is the same as described here, but the length of the **island bus sections** is reduced.

(see rule 23 on Page 94).

## 10.6.4 Island bus expansion cable material

---

### Cable specifications for island bus expansion

The cables must meet the following specifications:

- Shielded cable (foil or mesh)
- Capacitance between wires + and – <50 pF/m
- Wave resistance between wires + and – 100...120 Ohm
- Specific resistance for wires + and – <100 Ohm/km (AWG24 or thicker)

### Cable types

The following cable types normally suit the requirements for island bus expansion.

**However, always check if the above specifications are fulfilled!**

- RS422 / RS485  
(almost all cables are suitable)
- Ethernet CAT 5, CAT 6, or CAT 7  
(cables for Power over Ethernet; other cables have insufficient copper cross section.)

### Examples

- Bedea
  - Type 3197, S/STP, CAT7+, 43 pF/m, 100 Ohm, <=80 Ohm/km (AWG23)
  - Type 2374, S/STP, CAT7, 43 pF/m, 100 Ohm, <=80 Ohm/km (AWG23)
  - Type 2279, S/STP, CAT6, 43 pF/m, 100 Ohm, <=80 Ohm/km (AWG23)
  - Type 2103, S/UTP, CAT5, 48 pF/m, 100 Ohm, <=94 Ohm/km (AWG24)
  - Type 2102, F/UTP, CAT5, 48 pF/m, 100 Ohm, <=95 Ohm/km (AWG24)
- Belden
  - Type 9841, for RS-485, 42 pF/m, 120 Ohm, 79 Ohm/km (AWG24)
  - Type 9729, for RS-422, 41 pF/m, 100 Ohm, 79 Ohm/km (AWG24)
  - Type 8102, for RS-422, 41 pF/m, 100 Ohm, 79 Ohm/km (AWG24)
  - Type 3084A, for DeviceNet, 39 pF/m, 120 Ohm, 92 Ohm/km (AWG24)

## Wiring

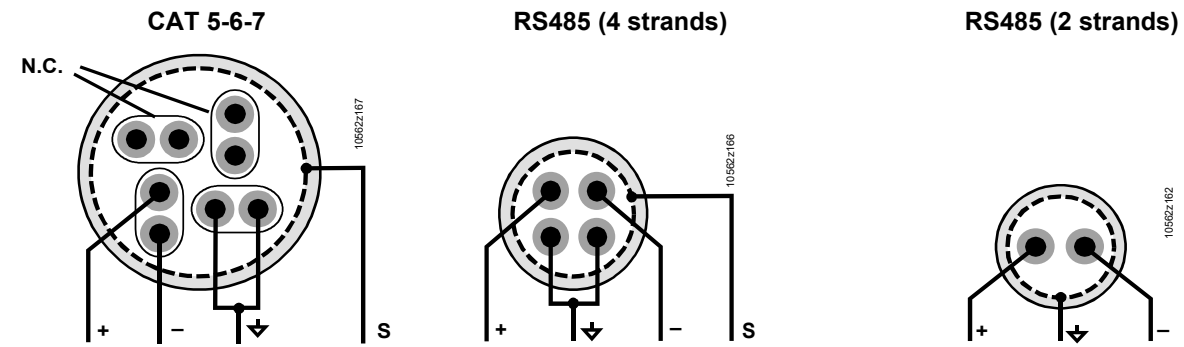

PELV and SELV are admissible

PELV and SELV are admissible

PELV only is admissible

S = screen connection (optional)  
on both ends as described on page 52

N.C. = do not connect

*(This wiring usually works with SELV as well, but there is no guarantee!)*

## Insulation

**Cable for conductors CS and  $\perp$** , that are routed with the island bus expansion (see earthing examples, page 96 and examples T and U, page 101):  
insulation at least 400 V; cross section at least 1.5 mm<sup>2</sup> / AWG16.

For wiring examples refer to section 10.6.6.

## Use of existing remote P-Bus cables

The existing RG-62 cables for remote P-bus connections may be used for the island bus expansion, when re-wired as follows (only PELV systems).

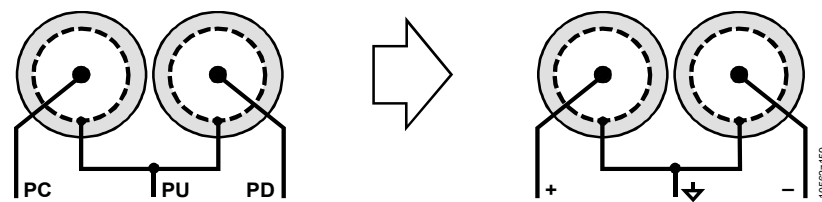



## Earthing rules

For earthing rules, refer to section 6.4.1, for wiring examples refer to section 10.6.6







## Topology rules

13. Only a line topology is permitted with the island bus expansion.
14. Per sub-island a maximum of one island bus expansion module is permitted.
15. No cascading (i.e. no connection from a decentralized sub-island to another decentralized sub-island).
16. One I/O island can consist of one local sub-island and up to 8 decentralized sub-islands.
17. For island bus wiring in sub-islands (local and decentralized), the rules as described in Section 10.6 apply, with the exception of distances  $L_{max}$ , see rule 21.
18. Tools (XWP, DTS, etc.) and operator units (PXM...) can only be connected to the local sub-island (where the manager of the island bus expansion is located).

## Maximum wire lengths for island bus expansion

19. The admissible length of the island bus expansion is 400 m.
20. The maximum distance between the local sub-island (**B**) and the most distant decentralized sub-island (**F**) must not exceed 200 m.

### Key

-  = I/O row with AS or BIM
-  = I/O row
-  = cable island bus expansion
-  = do not add distance
-  = cable island bus
-  = add distances

B...G see glossary, page 93

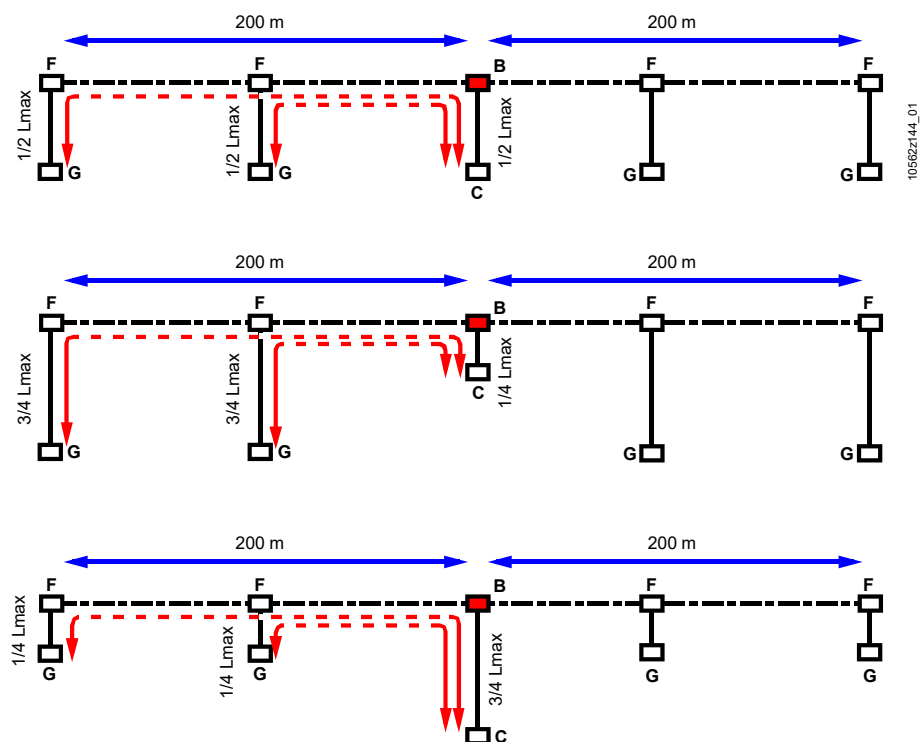

## Maximum wire length for island bus

21. The length must be counted on both sides of the expansion for the **island bus**. The sum total may not exceed  $L_{max}$  per Section 10.5. **(Installation examples in Section 10.6.7 only deal with the case  $\frac{1}{2} L_{max}$ ).**
22. The **power** can be **increased proportionally** or the **wiring cross section reduced** since the island bus per sub-island is shorter than  $L_{max}$ .
23. For TX-I/O modules **series B** and **P-Bus-BIM series A**, only  $\frac{1}{4} L_{max}$  is permitted for the sum total.  
Reason: The island bus circuits for these devices are not optimized for island bus expansion.

**Bus manager, bus connection rules**

The island bus expansion module has DIP switches to set the functions "bus manager" and "bus terminator".

Communication can be interrupted when the switches are incorrectly set; there are no obvious symptoms, however, when a switch is incorrectly set.

- 24. When both **BM switches** are on, the island bus expansion modules serves as the **island bus manager**.

This is required for decentralized sub-islands. The automation station or the BIM is the manager for local sub-island.

- 25. When both **BT switches** are on, the island bus expansion module serves as the **bus termination**.

Required on the segment end and on the local sub-island .

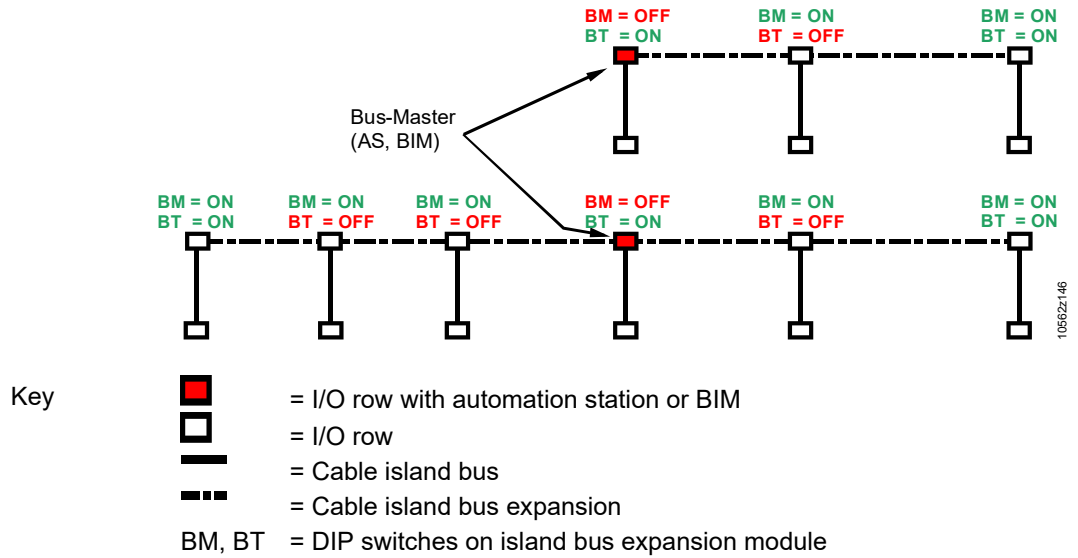

**Hot plugging**

- 26. As is the case for all island bus devices, the island bus expansion module can be installed during operation.

## 10.6.6 Wiring examples for island bus expansion

Wiring of the island bus expansion can be done in different ways, depending on

- the earthing kind of the system (PELV, SELV)
- the cables used (Cat 5, RS-485, RG-62).







Admissible cable types are described in 10.6.4.

Admissible cable lengths see above, rule 19.

When choosing a protection system (PELV, SELV), local safety regulations must be observed.

A simple and effective installation is achieved with PELV earthing and CAT 5 (AWG24) cable.

Key Earthing and installation examples contain the following elements:

      	Automation station with island bus connector + power supply module	TXS1.12F10
	Bus Interface Module with built-in power supply	TXB1.P-BUS
	PROFINET BIM TXB1.PROFINET + power supply module	TXS1.12F10
	Power supply module	TXS1.12F10
	Bus connection module	TXS1.EF10
	Island bus expansion module	TXA1.IBE
	TX-I/O module	TXM1....
—	Cable island bus	
- - -	Cable island bus expansion	

### Notes on earthing

- **Earthing of the screens (  , all examples):**  
When you expect medium or high EMC disturbance, we recommend earthing of the screens (on both ends) as described on page 52.
- **Earthing of field devices (not shown in the examples):**  
Earthing (e.g. external sensor power) should be avoided.

The following illustrations show wiring examples for different earthing kinds (PELV, SELV) and different cables.

PELV  
RS485 (2 conductors)

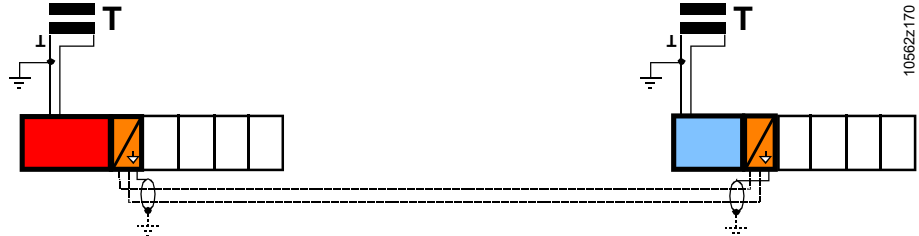

Connect the cable screen directly to the equipotential terminals  $\nabla$  of the island bus expansion modules on both ends.

PELV  
CAT 5 or  
RS485 (4 conductors)

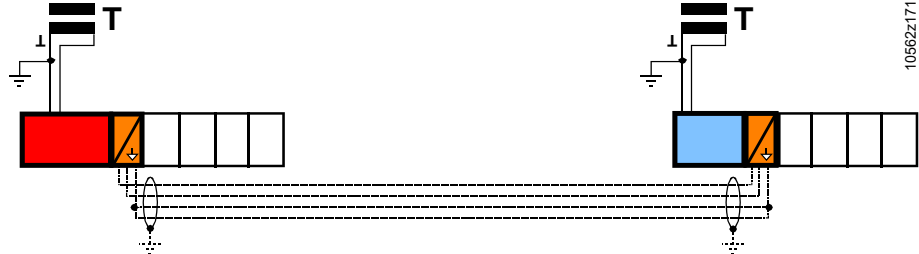

The equipotential bonding between the island bus expansion modules is done via a pair of conductors in the bus cable, connected in parallel.

PELV  
RG-62

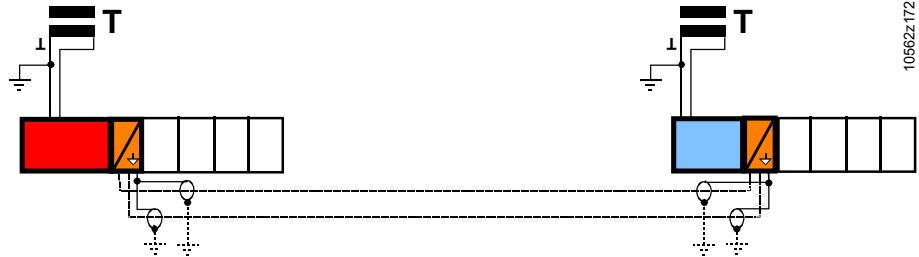

RG-62 cables of an existing remote P-bus installation can be re-used when migrating to TX or PX. Connect the cable screens of both cables to the equipotential terminals  $\nabla$  of the island bus expansion modules on both ends.

SELV  
RS485 (2 conductors)

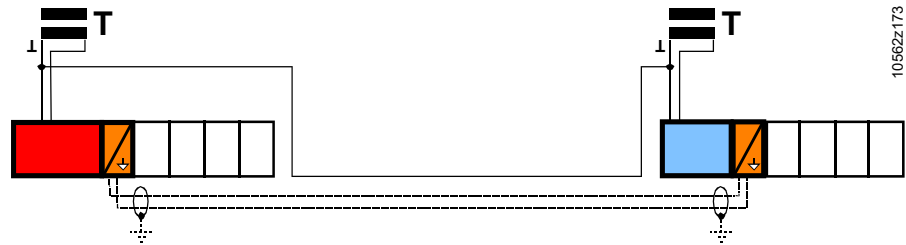

10562z173

SELV  
CAT 5 or  
RS485 (4 conductors)

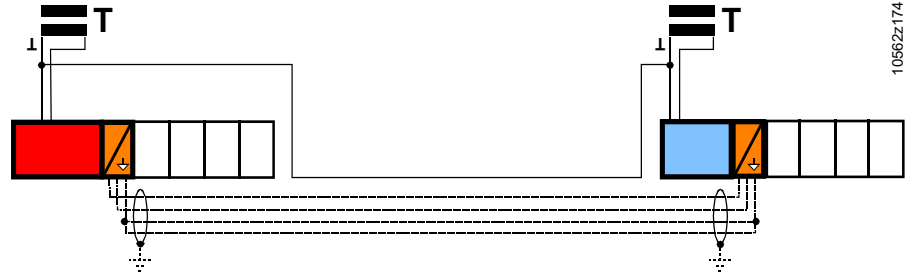

10562z174

Connect the bus cable as in a PELV system.  
Additionally, system neutral of the two transformers must be connected by a separate cable. Tie the bus cable and the system neutral cable together to avoid loops (inductive disturbance).

SELV  
RG-62

RG-62 cables of an existing remote P-bus installation can not be re-used!

Decentralized sub-islands without a power supply module

Sub-islands with only a few data points (e.g. DIs) can be run without a power supply module.

DC 24 V for the supply of the modules (conductors CS und ⊥) is fed via a bus connection module.

PELV  
CAT 5 or RS485

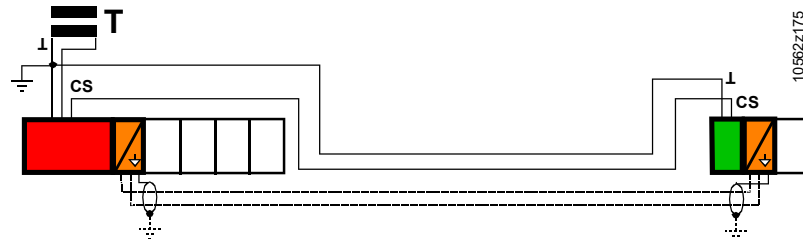

10562z175

SELV  
CAT 5 or RS485

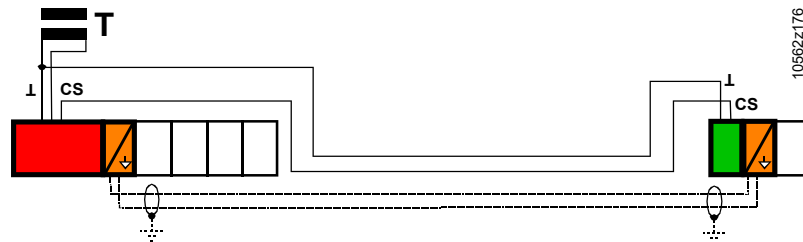

10562z176

- Notes
- Tie connectors ⊥ and CS together to avoid earth loops.
  - **Earthing is not admitted**, high balancing currents might occur.
  - Dimensioning of the sub-islands: refer to section 10.6.7, examples A, T, U..

## 10.6.7 Installation examples for island bus expansion



Note!

- In the installation examples, the island bus length is the same on both side of the island bus expansion ( $1/2 L_{max}$ ). Concerning  $L_{max}$ , please refer to page 83.
- Permissible power changes when other lengths are selected (see rule 21).

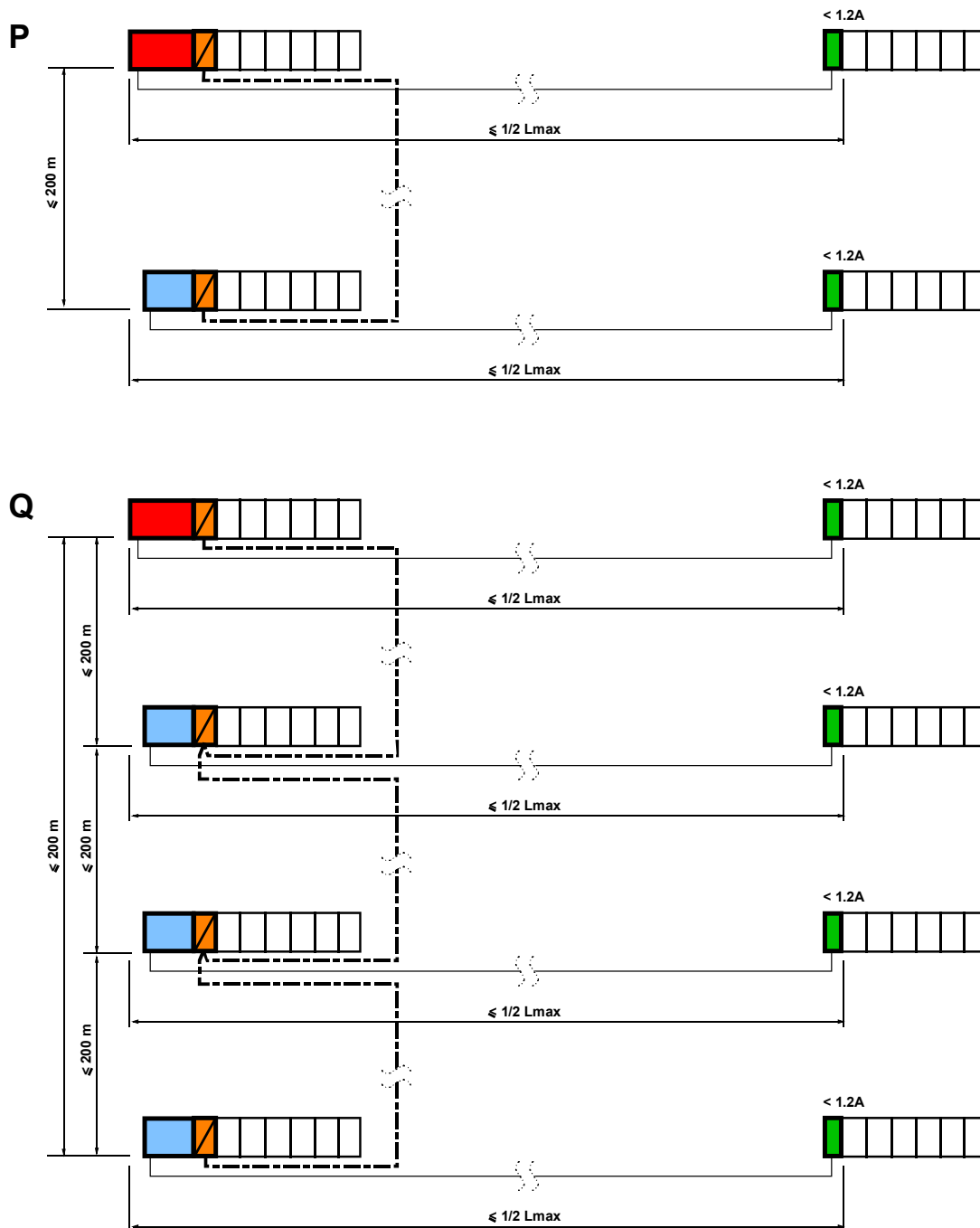

- Notes
- Example P illustrates (versus example A) that power can be doubled thanks cutting the length of the island bus in half ( $1/2 L_{max}$ , Rule 21 / 22, page 94) ( $1.2A$  instead of  $0.6 A$  in the remote I/O row).
  - Example Q illustrates
    - (versus example P), for each sub-island, the island bus length " $1/2 L_{max}$ " is once again allowed.
    - the length of the island bus expansion segment (max.  $200$  m) can be distributed as desired on decentralized sub-islands (in extreme cases  $198 + 1 + 1$  m,  $1 + 198$  m +  $1$  or  $1 + 1 + 198$  m).

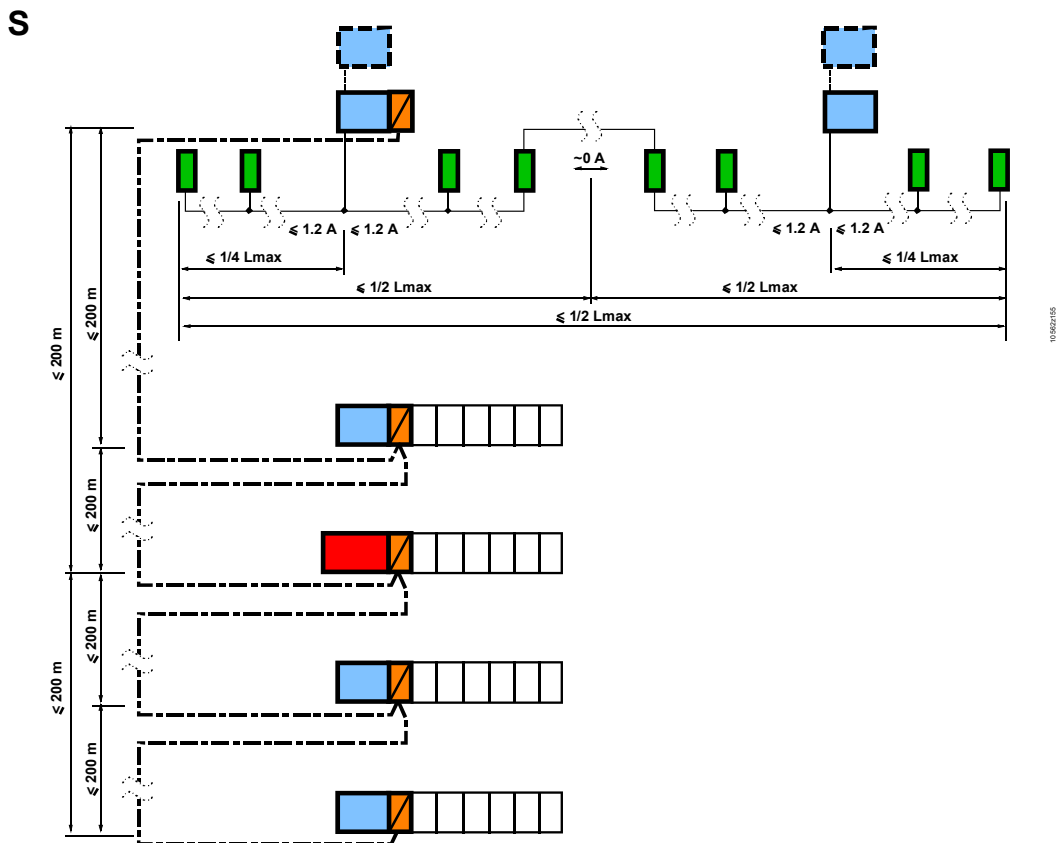
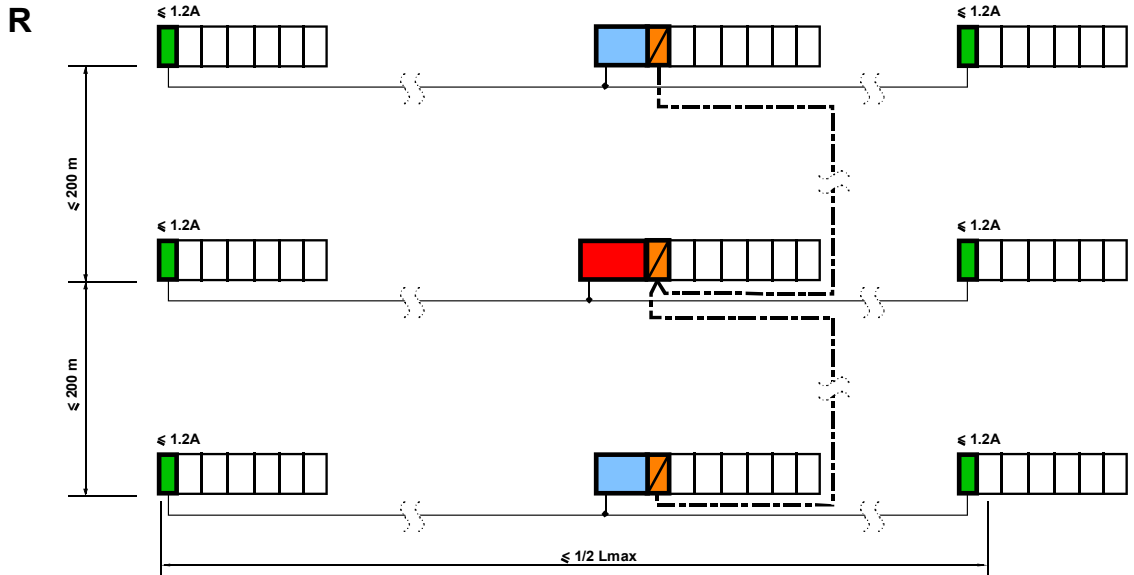

- Notes
- Example R illustrates 2 segments for the island bus expansion up to a maximum each of 200 m.  
The island bus length for each sub-island may be a maximum of  $1/2 L_{max}$  (Rule 23, page 94)
  - Example S illustrates, that
    - each decentralized sub-island may have multiple power supply modules (up to 4 as is the case in example K).
    - the overall length of the island bus in a sub-island is a maximum of  $1/2 L_{max}$  (Rule 21 / 22, page 94).  
The partial lengths conform to the laws of current, voltage drop and line diameter.

**Solutions for sub-islands without power supply modules**



**Note!**

In these examples earthing is not admitted because conductor  $\perp$  carries supply currents. **Case 2 B.**

First, for comparison purposes, **example A** without island bus expansion. The following lengths and power are permitted per page 83:

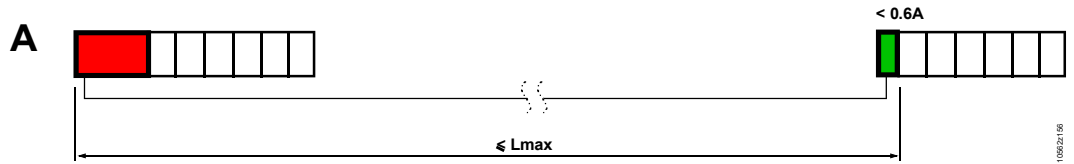

Cable island bus (wire CS, CD and $\perp$ )	Length Lmax	Max. power for remote I/O row
Round cable 2.5 mm <sup>2</sup> / AWG14	50 m	0.6 A
Coaxial cable parallel with 2.5 mm <sup>2</sup>	100 m	0.6 A

**Example T** illustrates how the distance can be increased by resolving communication of the decentralized I/O row with the island bus expansion, power (wire CS and  $\perp$  only) can, however, originate from the local sub-island.

This solution is of interest when the decentralized I/O row has only a few I/O modules with little power consumption (e.g. digital or analog inputs, see page 102), and you do not want to install a power supply module.

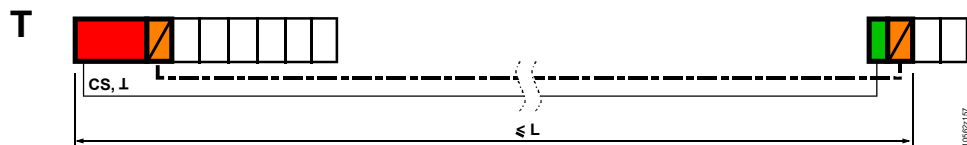

Cable island bus (wire CS and $\perp$ only)	Length L	Max. power for decentralized I/O row
Round cable 2.5 mm <sup>2</sup> / AWG14	200 m	150 mA (of which 50 mA for TX1A.IBE)
Round cable 2.5 mm <sup>2</sup> / AWG14	100 m	300 mA (of which 50 mA for TX1A.IBE)
Round cable 2.5 mm <sup>2</sup> / AWG14	50 m	600 mA (of which 50 mA for TX1A.IBE)

**Example U** illustrates decentralized mini I/O rows analogous to example C and distributed over a maximum length of 100 m.

The long distance reduces permissible power to 150 mA, in other words, one I/O module can be operated.

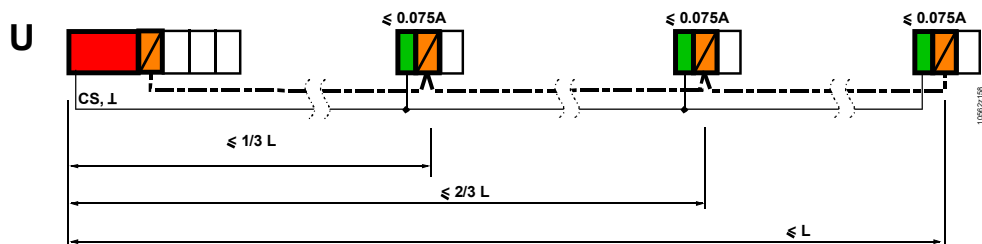

Cable island bus (wire CS and $\perp$ only)	Length L	Max. power for each decentralized I/O row
Rounds cable 2.5 mm <sup>2</sup> / AWG14	100 m	150 mA (of which 50 mA for TX1A.IBE)

**Note** Distances and power in the power cables (wire CS and  $\perp$ ) are based on the specification that a maximum voltage drop of 0.5 V is allowed on both CS and  $\perp$ . The reasons, however, in examples T and U is not the stability of island bus communication, but rather the power supply for decentralized I/O modules: When the power supply module / P-Bus-BIM provides only the minimum specified voltage of 22.5 V, then only 21.5 V remains at the end of the wire for the last I/O module.

## 10.7 Cables for field devices

See below, Sections 10.11 ff.

## 10.8 Consumption data DC 24 V

### Consumption, general

Consumption data for the following devices is required as an aid to transformer and supply sizing and to estimate the heat emitted in the control panel:

- Transformers (intrinsic consumption)
- Automation stations
- Other controllers
- Bus interface modules
- Power supply modules (intrinsic consumption)
- All individual I/O points
- Field devices (connected to the module supply or to separate transformers)

### Consumption data DC 24 V per I/O point (values in mA, for supply sizing)

Type	TXM1.8D	TXM1.16D	TXM1.8U	TXM1.8U-ML	TXM1.8X *	TXM1.8X-ML *	TXM1.8P	TXM1.6R	TXM1.6R-M	TXM1.6RL	TXM1.8RB	TXM1.8T	TXM1.4D3R	TXA1-IBE	TXI2(-S)-OPEN
Intrinsic consumption <sup>1)</sup>	25	25	35	60	30	35	35	20	30	25	25	10	10	50	55
Digital input <sup>2)</sup> (contact closed)	3.5	2.5	3	3	2	2							2		
Analog input <sup>3)</sup> (Temp. sensors Ni, PT, Pt100_4, T1)			0	0	0	0	0								
Analog input <sup>3)</sup> (Temperature sensor NTC)			0	0	0	0									
Analog input <sup>3)</sup> Resistance, TXM1.8P also Pt100_4)			1	1	0.5	0.5	1								
Analog input (10 V) <sup>2)</sup>			1	1	0.5	0.5									
Analog input (20 mA) <sup>2)</sup> Supply external or AC 24 V					0.5	0.5									
Analog input (20 mA) 2-wire <sup>2)</sup>					20	20									
Analog input (20 mA) 3-wire <sup>2) 4)</sup>					25	25									
Digital output (relay active) <sup>2)</sup>								8	8	12	8		8		
Digital output (triac active) <sup>2) 5)</sup>												4			
Analog output (10 V) <sup>2)</sup>			3	3	2.5	2.5									
Analog output (20 mA) <sup>2)</sup>					18	18									
Unconfigured I/O point (Reserve for later configuration)	3.5	2.5	3	3	25	25	1	8	8	12	8	4	2 / 8		

<sup>1)</sup> Including module status LED; includes LCD and all override LEDs if applicable

<sup>2)</sup> Including I/O status LED

<sup>3)</sup> Included in intrinsic consumption (no I/O status LED for temperature inputs)

<sup>4)</sup> The table assumes 5 mA to supply the current sensor, which should be sufficient for most models. If in doubt, please refer to the sensor data sheet.

<sup>5)</sup> The triacs have a switch capacity of **AC** 24 V, 125 / 250 mA (max 500 mA for 90 s). This power is supplied by the 24 V ~ conductor, not by the DC 24 V power supply.

 **Note!**

\*) The **DC 24 V** consumption (from the modules) by field devices other than current sensors must be counted separately.  
Admissible current for each TXM1.8X, TXM1.8X-ML module: 200 mA  
(see Section 10.2).

## 10.9 AC 24 V transformer sizing

The engineering responsibility includes transformer sizing.

The selected transformer rating is based on the total power consumption of the automation station, the I/O modules and the connected field devices.

Refer to the engineering principles in this section and the system-specific regulations in Section 2.3.

Item	Regulations
AC 24 V operating voltage	<ul style="list-style-type: none"><li>• The operating voltage is AC 24 V. It must comply with SELV or PELV to HD 384 requirements.</li><li>• The acceptable deviation of the AC 24 V nominal voltage connected to the transformer is +20%/–10%. This means that after taking account of the cable and contact resistances, a tolerance of +/- 20 % for the field device supply can be guaranteed in the field devices.</li></ul>
Specification for AC 24 V transformers	<ul style="list-style-type: none"><li>• Double-insulated safety transformers to EN 61558, designed for continuous operation, to supply SELV or PELV circuits.</li><li>• For reasons of power efficiency the power drawn from the transformer should be at least 50 % of the nominal load.</li><li>• The rated transformer output must be at least 50 VA. In smaller transformers the ratio of no-load voltage to full-load voltage is unfavorable (&gt; +20 %).</li></ul>

## 10.10 Fuses

The engineering responsibility includes sizing of fuses.

Item	Regulations
<p>Fuses to protect the AC 24 V operating voltage</p> <p> <b>Important</b></p>	<p><b>Transformer secondary winding:</b> based on the effective load of all connected devices as determined by the transformer sizing:</p> <ul style="list-style-type: none"> <li>• AC 24 V (system potential) must always be fused.</li> <li>• Where specified, an additional fuse must be provided for the reference conductor <math>\perp</math> (system neutral).</li> </ul> <p><b>Such fuses are generally useful in distributed installations to prevent unwanted earth currents (e.g. when a sensor is earthed by error).</b></p> <ul style="list-style-type: none"> <li>• The 10 A fine-wire fuses fitted to the power supply units to protect the I/O island are not a substitute for the load-dependent back-up fuse.</li> </ul>
<p>AC 230 V mains voltage protection</p>	<ul style="list-style-type: none"> <li>• <b>Transformers, primary winding:</b> Control panel protection (control circuit fuse).</li> <li>• The mains voltage routed to the TX-I/O modules (<b>supply cable for relay contacts</b>) must have one of the following: <ul style="list-style-type: none"> <li>– slow blow fuses of max. 10 A</li> <li>– miniature circuit breakers of max. 13 A (characteristics B/C/D).</li> </ul> </li> </ul>

## 10.11 Digital inputs (status and counting)

### Cable length

The permissible length of the cables connected to the status contacts and counter contacts, regardless of the thickness of the wire (min. diameter 0.6 mm) is restricted to 300 m and is defined by the anticipated noise interference.



### Counter inputs

Counter inputs faster than 1 Hz that are routed for more than 10 m in the same trunking as analog inputs must be shielded.

### Common $\perp$ conductor with multiple contacts

When several status or counter contacts are to be connected, a common  $\perp$  conductor may be used. This saves wiring.

However, system ground must be connected at least once per module (see 6.6).

Connection diagram  
(Example)

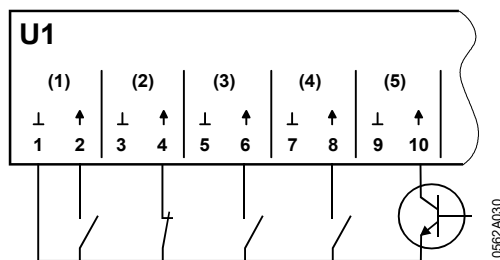

In principle, the number of contacts that can be connected via a common  $\perp$  conductor depends on the length and cross section of the conductor.

However, the measuring current (1 ... 1.6 mA) is so small that all 16 inputs of a TXM1.16D module can be connected with the minimum cross section 0.28 mm<sup>2</sup> (0.6 mm diameter) and with the maximum cable length of 300 m.

### Technical data

Digital inputs /  
counter inputs

Digital inputs are not electrically isolated from the system electronics.

Mechanical contacts must be volt-free.

Electronic switches must comply with SELV or PELV standards.

Contact sensing voltage	DC 21.5 ... 25 V
Contact sensing current (TX1.8X, 8U)	1.0 mA (initial current 6 mA)
Contact sensing current (TX1.8D, 16D, 4D3R)	1.6 mA (initial current 10 mA)
Insulation resistance with contacts closed	Max. 200Ω
Contact resistance with contacts open	Min. 50kΩ

A = TXM1.8D, 16D, 4D3R B = TXM1.8U, 8U-ML, TXM1.8X, 8X-ML	Min. closing / opening time [ms] including bouncing		Max. bounce time [ms]		Max. counting frequency (symmetric)	
	A	B	A	B	A	B
Maintained contact	80	60	40	20		
Pulse contact	50	30	30	10		
Counter mechanical <sup>1)</sup>	40	20	30	10	10 Hz	25 Hz
Counter electronic <sup>2)</sup>		5		0	10 Hz	100 Hz

Counter inputs

counter memory 0 ... 4.3 x 10<sup>9</sup> (32 bit counter)

1) TXM1.16D: I/O points 1 ... 8 only

## 10.12 Analog inputs

### 10.12.1 Passive resistance sensors and resistance transmitters (2-wire connection)

Measured value acquisition and measured signal

The temperature sensors register the temperature by means of a nickel or platinum wire or a semiconductor which change their resistance in relation to the temperature.

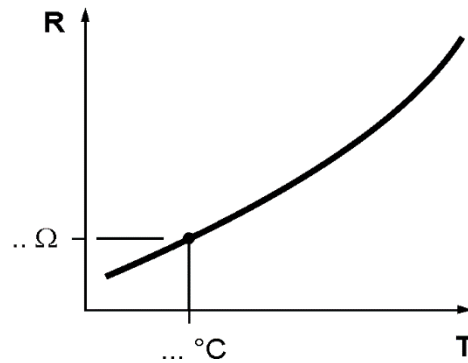

Key:

R Sensor signal (resistance)

T Actual temperature

Resistance table

The table below shows the resistance of the supported sensor elements as a function of the temperature.

Temp °C	AI Ni1000	AI Pt1K375	AI Pt1K385	AI Pt100	AI T1	AI NTC10K	AI NTC100K
	TCR 5000 (LG-Ni 1000) ohm	TCR 3750 (USA) Ohm	TCR 3850 (Europa) EN60751 Ohm	TCR 3850/10 Ohm	(PTC) Ohm 2)	Beta 3890 Ratio 9.065 kOhm	Beta 3891 Ratio 9.062 kOhm
-50	790.9	807.9	803.1	80.3	1 747.7		
-40	830.8	846.6	842.7	84.3	1 840.4	336.487	3'386.091
-30	871.7	885.1	882.2	88.2	1 934.6	176.974	1'773.139
-20	913.5	923.5	921.6	92.2	2 030.3	97.080	970.613
-10	956.2	961.8	960.9	96.1	2 127.6	55.332	552.830
0	1 000.0	1'000.0	1'000.0	100.0	2 226.4	32.650	326.329
10	1 044.8	1'038.0	1'039.0	103.9	2 326.9	19.904	198.958
20	1 090.7	1'076.0	1'077.9	107.8	2 429.1	12.494	124.920
30	1 137.6	1'113.8	1'116.7	111.7	2 532.9	8.057	80.567
40	1 185.7	1'151.4	1'155.4	115.5	2 638.5	5.326	53.256
50	1 235.0	1'189.0	1'194.0	119.4	2 745.9	3.602	36.010
60	1 285.4	1'226.4	1'232.4	123.2	2 855.1	2.488	24.864
70	1 337.1	1'263.8	1'270.8	127.1	2 966.2	1.752	17.505
80	1 390.1	1'301.0	1'309.0	130.9	3 079.3	1.256	12.549
90	1 444.4	1'338.0	1'347.1	134.7	3 194.4	0.916	9.149
100	1 500.0	1'375.0	1'385.1	138.5	3 311.4	0.679	6.777
110	1 557.0	1'411.8	1'422.9	142.3	3 430.6	0.510	5.095
120	1 615.4	1'448.6	1'460.7	146.1	3 552.0		3.884
130	1 675.2	1'485.2	1'498.3	149.8	3 675.5		
140	1 736.5	1'521.6	1'535.8	153.6	3 801.4		
150	1 799.3	1'558.0	1'573.3	157.3	3 929.5		
160	1) 1'863.6	1'594.2	1'610.5	161.1			
170	1) 1'929.5	1'630.3	1'647.7	164.8			
180	1) 1'997.0	1'666.3	1'684.8	168.5			
200			1'758.6	175.9			
250			1'941.0	194.1			
300			2'120.5	212.1			
350			2'297.2	229.7			
400			2'470.9	247.1			
450			2'641.8	264.2			
500			2'809.8	281.0			
550			2'974.9	297.5			
600			3'137.1	313.7			

1) Ni1K only

2) Not measurable with ohm meter

Temperature supported only with reduced hum injection (details see page 115)

## Cable length

The maximum permissible cable length for passive resistance sensors and transmitters depends on the permissible measuring error due to the line resistance (see the graphs below).

The maximum cable length is 300 m.

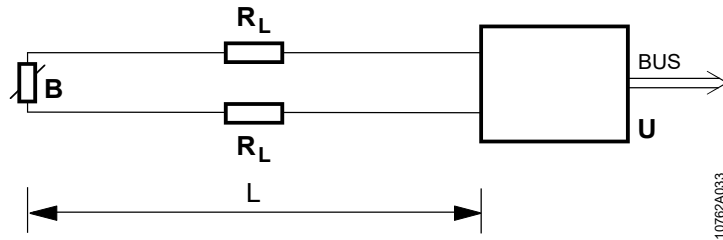

Key	B	LG-Ni resistance sensor or resistance transmitter
	L	Cable length
	R <sub>L</sub>	Line resistance
	U	Measured value input of I/O module

## Line resistance ("Sensor calibration")

The measured value functions are already adjusted with a line resistance of 1 ohm and the graphs below take account of this.

Exception: the 4-wire signal types Pt100\_4 and P100 as well as NTC10K and NTC100K.

The sensor calibration can also be adjusted via software configuration in the automation station in cases where measuring errors are caused by deviations in the line resistance or by specific ambient conditions (Intercept in CFC, see section 10.12.2).

## Measured value error LG-Ni 1000

The graphs below are for copper cable.

a) Measured value error due to line resistance

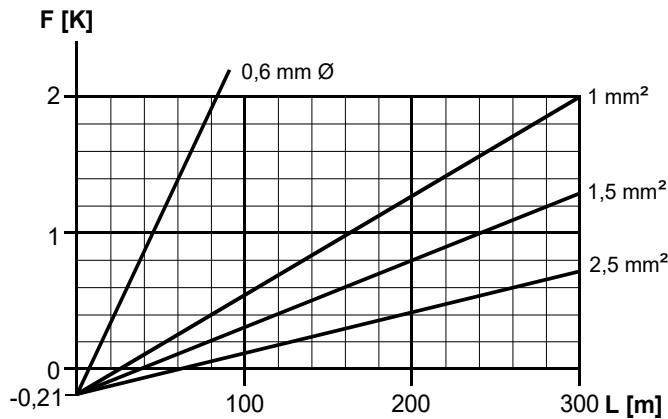

$$\text{Formula: } F = \frac{2 \cdot L}{57 \cdot A} - 1$$

Key	A	Cable cross-section in mm <sup>2</sup>
	F	Measured temperature error in K
	L	Cable length in m

**Measured value error  
LG-Ni 1000**

b) Measured value error due to explosion protection devices

Overvoltage protection devices can falsify the measured value of analog inputs.  
*Example:* Phoenix type PT 1X2-12DC-ST/28 56 02 9 has an internal protective impedance which causes a measuring error of +1K, but only for LG-Ni 1000 sensors.

**Measured value error  
Pt 1000 sensor**

**Pt 1000 Ω sensors:** Measured value error due to line resistance

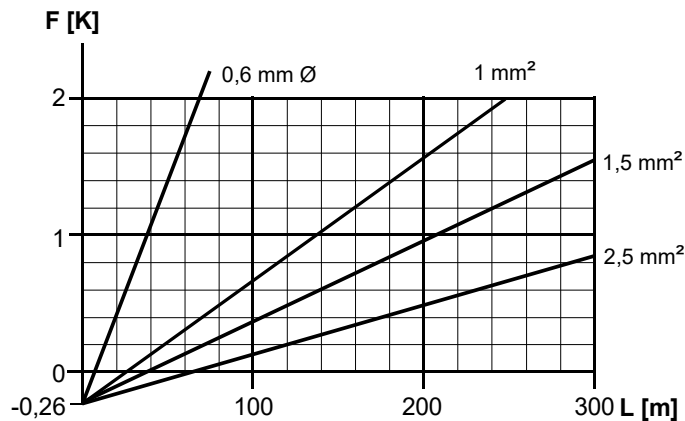

$$\text{Formula: } F = \frac{2 \cdot L}{57 \cdot A} - 1$$

Key  
A Cable cross-section in mm<sup>2</sup>  
F Measured temperature error in K  
L Cable length in m

**Measured value error  
Pt 100 sensor  
(4-wire)**

- The 4-wire circuit serves to eliminate the error due to line resistance. The measuring value function has no predefined line resistance.
- in addition, the very small pulsed sensor current minimizes the internal heat dissipation in the Pt100 sensor.

**Measured value error  
T1**

**T1 sensors:** Measured value error due to line resistance:

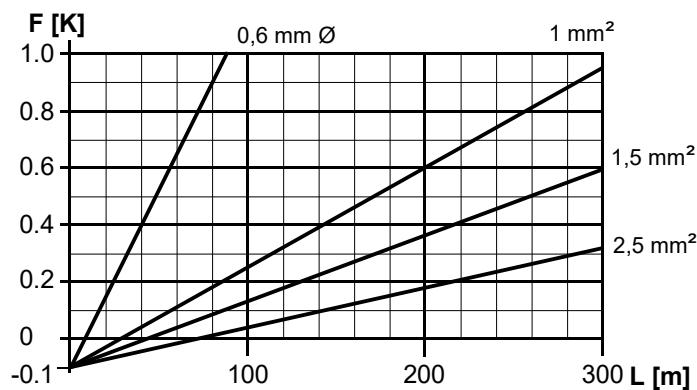

$$\text{Formula: } F = \frac{2 \cdot L}{57 \cdot A} - 1$$

Key  
A Cable cross-section in mm<sup>2</sup>  
F Measured temperature error in K  
L Cable length in m

**Measured value error  
NTC sensor**

Measured value error of NTC sensors due to line resistance:  
The sensors are highly non-linear. But thanks to the high sensor resistance the errors are very small.

Error compared to T1:

	NTC 100K	NTC10K
20°C	x 0.01	x 0.1
100°C	x 0.1	x 1 (~ equal)

**Measured value error  
Resistance transmitters**

**Resistance transmitters (potentiometers):**

a) Measured value error due to line resistance

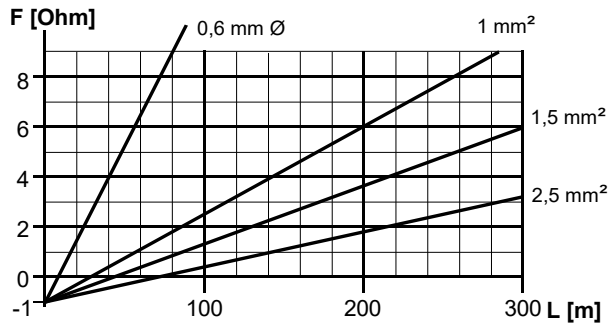

$$\text{Formula: } F = \frac{2 \cdot L}{57 \cdot A} - 1$$

- Key A Cable cross-section in mm<sup>2</sup>
- F Measurement error in ohms, due to line resistance (2RL for supply and return conductor)
- L Cable length in m

**Measured value error  
Resistance transmitters**

b) Measured value error due to explosion protection devices

Explosion protection devices can falsify the measured value of analog inputs.  
*Example:* Pepperl & Fuchs type CFD2-RR-Ex19 causes significant measuring errors for resistance values of <30 ohms. Resistances >30 ohms are measured correctly.

## 10.12.2 Correcting the line resistance with [lcpt]

For analog inputs (measuring of temperature or resistance), most signal types are calibrated for a line resistance of 1 Ohm.

**Desigo:** If the line resistance differs significantly from 1 Ohm, [lcpt] can be changed in the AI block.

**PROFINET BIM:** The line resistance can be configured in the S7 HW Config Tool using parameter "Compensation".

### Resistance measuring

Line resistance	[Slope]	[lcpt]	Delta Slope	Delta Intercept
<b>AI PT1K385 (Europe)</b>				
0 Ohm	0.0259740	-259.480519	0	0.259740
Default = 1 Ohm	0.0259740	-259.740260	0	0
2 Ohm	0.0259740	-260.000000	0	-0.259740
3 Ohm	0.0259740	-260.259740	0	-0.519481
<b>AI PT1K375 (USA)</b>				
0 Ohm	0.0266667	-266.400000	0	0.2667
Default = 1 Ohm	0.0266667	-266.666667	0	0
2 Ohm	0.0266667	-266.933333	0	-0.2667
3 Ohm	0.0266667	-267.209900	0	-0.5333
<b>AI 2500 Ohm, AI PT1000 (0 ... 2500 Ohm)</b>				
0 Ohm	0.1	1	0	1
Default = 1 Ohm	0.1	0	0	0
2 Ohm	0.1	-1	0	-1
3 Ohm	0.1	-2	0	-2
<b>AI 250 Ohm *)</b>				
0 Ohm	0.01	1	0	1
Default = 1 Ohm	0.01	0	0	0
2 Ohm	0.01	-1	0	-1
3 Ohm	0.01	-2	0	-2
<b>AI PT100 (0 ... 250 Ohm *)</b>				
Default = 0 Ohm	0.01	0	0	0
1 Ohm	0.01	-1	0	-1
2 Ohm	0.01	-2	0	-2
3 Ohm	0.01	-3	0	-3

\*) **TX-I/O modules with island bus integration:** **AI Pt100 4 wire** is a 4-wire type

Default line resistance = 0 Ohm

Do not compensate the line resistance!

**AI 250 Ohm** is a 2-wire type

Default line resistance = 1 Ohm

**TX-I/O modules with integration via P-Bus-BIM:** **Pt100\_4** is a 4-wire type

Default line resistance = 0 Ohm

Do not compensate the line resistance!

**R250** is a 2-wire type, but it must be connected to 4 terminals with jumpers

Default line resistance = 0 Ohm

**PT-I/O modules:** **P100** is a 4-wire type

Default line resistance = 0 Ohm

Do not compensate the line resistance!

Temperature measuring [1/100 °C]

Line resistance	[Slpe]	[lcpt]	Ohms per degree	degrees per Ohm	
<b>AI PT1K385 (Europe)</b>			3.85	0.259740	
0 Ohm	0.01	0.259740			
Default = 1 Ohm	0.01	0			
2 Ohm	0.01	-0.259740			
3 Ohm	0.01	-0.519481			
<b>AI PT1K375 (USA)</b>			3.75	0.266667	
0 Ohm	0.01	0.266667			
Default = 1 Ohm	0.01	0			
2 Ohm	0.01	-0.266667			
3 Ohm	0.01	-0.533333			
<b>AI Ni1000 extended</b>			5	0.2	
0 Ohm	0.01	0.2			
Default = 1 Ohm	0.01	0			
2 Ohm	0.01	-0.2			
3 Ohm	0.01	-0.4			
<b>AI T1 (PTC)</b>			9.57	0.104450	-50 ... 0 °C
0 Ohm	0.01	0.096246	<b>10.39</b>	<b>0.096246</b>	<b>0 ... 50 °C</b>
Default = 1 Ohm	0.01	0	11.31	0.088417	50 ... 100 °C
2 Ohm	0.01	-0.096246	12.36	0.080893	100 ... 150 °C
3 Ohm	0.01	-0.192493			

**Pt100\_4**

AI Pt100 4 wire is a 4-wire type  
 Default line resistance = 0 Ohm  
 → Do not compensate the line resistance!

### 10.12.3 Active sensors DC 0 ... 10 V

#### Measured value acquisition and measured signal

The active sensors use a signal amplifier which emits a standard DC 0...10 V signal. This voltage range is proportional to the application range of the sensor. A suitable measuring system is used to acquire the measured value.

Active sensors are available for:

- Relative humidity
- Pressure in liquid and gaseous media
- Differential pressure in liquid and gaseous media
- Air quality
- Air velocity

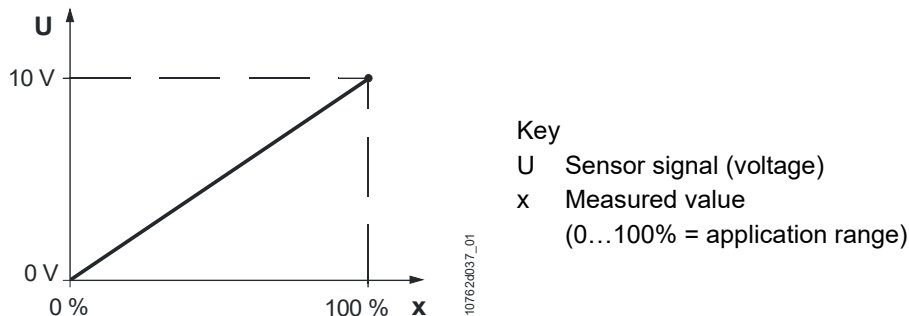

Note When the process value is outside -1.5...11.5 V, a fault message will be sent. For a workaround (Zener diode), see CM110563.

#### Cable length

The maximum cable length is 300 m.

The permissible length of DC 10 V cables for measured signals, and of the cables to supply the sensors from the I/O module, have to be calculated on the following basis for each active sensor (see also the relevant sensor data sheets):

- Max. 7 % voltage drop (1.68 V) on the cables due to the sensor supply current.  
Reason: to ensure sufficient voltage for the sensor supply (see Section 10.2)
- Measuring error of max. 0.5 % of the measuring range due to line resistance on the measuring conductor (not critical, as the measuring current is only 0.1 mA)

- Notes
- Longer cables are permissible provided larger measuring errors are acceptable.
  - The maximum cable length is 300 m.
  - If the active sensor is supplied locally from a transformer, the sensor cable can be up to 300 m long with a wire diameter of  $\geq 0.6$  mm.  
→ **The local transformer MUST NOT be earthed (earth loop)!**
  - In case of active sensors with AC 24 V supply, use cable cross section suited for 10 A according to local regulations (M 10A fuse in the power supply module / room automation station).



**Caution!**

**Cable length for devices with AC 24 V**

The maximum cable length is 300 m / 1000 ft (DXR2: 80 m / 260 ft).

The permissible length of the cables is calculated as follows: Voltage drop of max. 7 % (1.68 V) on the AC 24 V operating voltage for the sensor / actuator.

Cable cross section Power	Cable length				
	2 VA	5 VA	10 VA	20 VA	50 VA
<b>2.50 mm<sup>2</sup> / AWG14</b>	300 m 1000 ft	300 m 1000 ft	235 m 770 ft	120 m 390 ft	47 m 150 ft
<b>1.50 mm<sup>2</sup> / AWG16</b>	300 m 1000 ft	300 m 1000 ft	150 m 500 ft	75 m 250 ft	30 m 100 ft
<b>1.00 mm<sup>2</sup> / AWG18</b>	300 m 1000 ft	185 m 600 ft	95 m 300 ft	50 m 150 ft	20 m 60 ft
<b>0.75 mm<sup>2</sup> / AWG20</b>	290 m 960 ft	120 m 380 ft	60 m 190 ft	30 m 95 ft	12 m 40 ft

Note The outgoing and return cables may **each** have the indicated length.

**Cable length for devices with AC/DC 24 V**

These devices have an internal rectifier, to convert AC 24 V to DC 24 V. This causes a DC current to flow in the system neutral conductor (⊥) which causes a voltage drop over the line resistance. This voltage drop falsifies the DC 0...10 V signal value.

**The cable length must be reduced to limit the signal error (0.5%).**

Cable cross section Power	Cable length				
	1 VA	2 VA	5 VA	10 VA	20 VA
<b>2.50 mm<sup>2</sup> / AWG14</b>	140 m 460 ft	70 m 230 ft	30 m 90 ft	15 m 45 ft	8 m 25 ft
<b>1.50 mm<sup>2</sup> / AWG16</b>	90 m 290 ft	45 m 145 ft	20 m 60 ft	10 m 30 ft	5 m 15 ft
<b>1.00 mm<sup>2</sup> / AWG18</b>	55 m 180 ft	30 m 90 ft	12 m 35 ft	6 m 20 ft	3 m 10 ft
<b>0.75 mm<sup>2</sup> / AWG20</b>	35 m 110 ft	17 m 55 ft	7 m 25 ft	3 m 12 ft	2 m 6 ft

Note The outgoing and return cables may each have the indicated length.

### 10.12.4 Current inputs

- The current inputs are non-floating.
- The maximum cable length is 300 m.
- The admissible conductor cross section depends on the electrical data for the field devices.

## 10.12.5 Technical data for the analog inputs

Compensation of the line resistance

1 Ohm, calibrated in the module,  
(except for Pt100\_4, P100, NTC10K and NTC100K)

Signaltyp	Range (Under / over range) 5)	Resolution <i>island bus</i> 3)	Resolution <i>P-Bus-BIM</i> 3)	Resolution <i>PROFINET</i> <i>BIM</i> 3)	Sensor current (cyclic polling)
Temperature AI Pt100 4 Wire	-50...400 (600) °C 1) 2) (-52.5...610°C)	20 mK	86 mK	20 mK (Climatic) 100 mK (Standard)	2.1 mA
Resistance AI Pt100	0...250 Ohm 2) (0...265 Ohm)	10 mOhm	33 mOhm	--	2.1 mA
Resistance AI 250 Ohm (2-Draht)	0...250 Ohm 2) (0...265 Ohm)	10 mOhm	33 mOhm	100mOhm	2.1 mA
Temperature AI PT1K 375	-50...150 (180) °C 1) 6) (-52.5 ...185.0 °C)	10 mK		10mK	1.54 mA
Temperature AI PT1K 385	-50...400 (600) °C 1) (-52.5...610°C)	20 mK		100 mK	1.96 mA
Temperature AI Ni1000 (LG-Ni 1000)	-50...150°C (-52.5...155.0 °C)	10 mK	50 mK	10 mK	1.54 mA
Temp. AI Ni1000 extended (LG-Ni 1000)	-50...150 (180) °C 1) (-52.5...185.0 °C)	10 mK		10mK	1.54 mA
Resistance AI Pt1000	0...2500 Ohm (0...2650 Ohm)	100 mOhm	333 mOhm	--	1.96 mA
Resistance AI 2500 Ohm	0...2500 Ohm (0...2650 Ohm)	100 mOhm		100 mOhm	1.96 mA
Temperatuer AI T1 (PTC)	-50...130 (150) °C 1) (-52.5...155.0 °C)	10 mK	50 mK	10 mK	1.26 mA
Temperature AI NTC10K	(-40...115 °C) 1) (-52.5...155°C)	10 mK (25°C)		10 mK	0.14 mA
Temperature AI NTC100K	(-40 ...125 °C) 1) (-52.5...155°C)	10 mK (25°C)		10 mK	0.14 mA
Voltage measuring AI 0-10V	0 ... 10 V 4) (-1.5...11.5 V)	1 mV	3.125 mV	1 mV	
Current measuring AI 4-20mA	4 ... 20 mA (1.6...22.4 mA)	1 µA	5 µA	1 µA	
AI 0-20mA	<b>0 ... 20 mA</b> (-3.0...23 mA) (25 mA see CM10563)	1 µA	6.25 µA	1 µA	
Load resistance: 490 / 440 Ohms, pulsed (cyclic polling of the I/O points)					

1) (extended range) only with reduced hum injection (see below)

2) In **direct island bus integration**, Pt100\_4 and P100 are connected with 4 wires, R250 is connected with 2 wires.

The **P-Bus BIM integration in V4 and later** supports P100 4-wire and R250 2-wire, but R250 must be connected to 4 terminals with jumpers.

Connection diagrams see data sheet N8176.

The resolution with island bus is significantly better than with island bus BIM / P-Bus.

3) This section describes the measured resolution. (Desigo: It is different from the transmitted resolution that the bus delivers into the AI block and that is transformed by [Slpe] and [lcpt], see section 10.12.2).

**Caution!**

- 4) The range monitoring of signal type U10 is done with a short NEGATIVE signal of  $-3,1\text{ V}$ ,  $0.05\text{ mA}$  (open circuit detection). If a field device has an open output, a negative voltage could appear there. This can damage any polarized components (e.g. capacitors).
- 5) When the process value is outside the range, a fault message is issued.
- 6) AI PT1K375: Restriction for hum injection only for TXM1.8P.  
No restriction for TXM1.8U und TXM1.8X.

**"Reduced hum injection"**

TXM1.8U..., TXM1.8X...

Signal type	Normal hum			Reduced hum		
	$\text{mA}_{\text{eff}}$	Cable length	Temperature	$\text{mA}_{\text{eff}}$	Cable length	Temperature
AI Ni1000	0.5	300 m	-50 ... 150 °C	--	--	--
AI Ni1000 extended	0.5	300 m	-50 ... 150 °C	0.3	180 m	150 ... 180 °C
AI T1 (PTC)	0.5	300 m	-50 ... 130 °C	0.4	240 m	130 ... 150 °C
AI PT1K385	0.5	300 m	-50 ... 400 °C	0.25	150 m	400 ... 600 °C
AI PT1K375	0.5	300 m	-50 ... <b>180</b> °C	--	--	--
AI NTC100K	--	--	--	0.05	30 m	-40 ... 115 °C
AI NTC10K	--	--	--	0.05	30 m	-40 ... 125 °C

TXM1.8P

AI Ni1000	0.5	300 m	-50 ... 150 °C	--	--	--
AI Ni1000 extended	0.5	300 m	-50 ... 150 °C	0.3	180 m	150 ... 180 °C
AI PT1K385	0.5	300 m	-50 ... 400 °C	0.2	120 m	400 ... 600 °C
AI PT1K375	0.5	300 m	-50 ... <b>150</b> °C	0.4	240 m	150 ... 180 °C
AI Pt100 4 wire	0.5	300 m	-50 ... 400 °C	0.1	60 m	400 ... 600 °C

**Examples:**

AI Ni1000 extended

To realize the specified measuring accuracy, 0.5 mA of hum are admissible.

This hum is typically caused by a mains AC 230 V cable routed in the same cable duct as the measuring cable over a length of 300 m (cable lengths over 300 m are unfavorable for other reasons).

To measure temperatures over 150 °C accurately, the hum must be reduced to 0.3 mA. This can be achieved

- by reducing the length to 180 m
- by routing the measuring cable and the hum source in separate cable ducts
- by a shielded cable (connect the shield to system neutral  $\perp$  on one end).

AI NTC10K

NTC sensors are measured with a very small measuring current. To realize the specified measuring accuracy, only 0.05 mA of hum is admissible.

This hum is typically caused by a mains AC 230 V cable routed in the same cable duct as the measuring cable over a length of 30 m.

Measuring cables longer than 30 m must be shielded (connect the shield to system neutral  $\perp$  on one end).

## 10.13 Wiring for Triac outputs AC 24 V

The following applies for wiring to actuating devices such as valves, damper actuators or protection connected to the Triac outputs:

### Cable material

- Use stranded, 2 or multiple core round cables, screened (standard off-the-shelf installation cable).
- Single wires may not be used.

### Cable laying

- Wiring may be laid together with power lines (AC 230 V). They must be isolated from the power lines per regulations. Isolation must meet PELV requirements.
- Wiring cannot be led in the same cable as the power lines.

### Cable length and cross section



**Caution!**

- Use **cable cross section** suited for **10 A** according to local regulations (**M 10 A** fuse in the power supply module / room automation station).
- **Cable length**  $\leq$  300 m / 1000 ft (EM interference).

### Cable length

Calculation is based on a voltage drop of 0.48 V = 2% of 24 V (the triac and the PTC protection resistor have a voltage drop of 6%).

Cable cross section Power	Cable length				
	1 VA	2 VA	5 VA	10 VA	20 VA
<b>2.50 mm<sup>2</sup> / AWG14</b>	300 m 1000 ft	300 m 1000 ft	140 m 440 ft	70 m 220 ft	35 m 110 ft
<b>1.50 mm<sup>2</sup> / AWG16</b>	300 m 1000 ft	210 m 700 ft	85 m 280 ft	42 m 140 ft	21 m 70 ft
<b>1.00 mm<sup>2</sup> / AWG18</b>	270 m 880 ft	135 m 440 ft	50 m 180 ft	25 m 90 ft	13 m 45 ft
<b>0.75 mm<sup>2</sup> / AWG20</b>	170 m 550 ft	85 m 275 ft	33 m 110 ft	16 m 55 ft	8 m 27 ft

- Notes
- The outgoing and return cables may **each** have the indicated length.
  - Power = permanent load. The higher starting current of thermal or motorized actuators is admissible.

## 10.14 Wiring for Relay outputs

- External fuse of max. T 10 A for protection of the PCB tracks.
- The maximum load of the relay contracts must be observed (see data sheets for the corresponding devices). It may require a fusing <10 A.
- Relays have volt-free relay contacts.  
The mains voltage / switching voltage (AC 230 V / AC/DC 24 V) must be supplied as an external voltage to the terminals.
- The sizing and fusing of the lines are oriented to overall load and local regulations.



### Cable length AC 230 V

Actuators up to 100 VA: Lengths of up to 300 m / 1000 ft are admissible.  
**Wiring must comply with local regulations.**

### Cable length AC 24 V

Taking account of the permissible voltage drop, the cable between the switching outputs and the equipment to be switched may be up to 300 m / 1000 ft long.

The permissible lengths are calculated as follows:

Voltage drop of max. 7 % (1.68 V) on the AC 24 V operating voltage for the actuator.

Cable cross section Power	Cable length for AC 24 V				
	2 VA	5 VA	10 VA	20 VA	50 VA
<b>2.50 mm<sup>2</sup> / AWG14</b>	300 m 1000 ft	300 m 1000 ft	235 m 770 ft	120 m 390 ft	47 m 150 ft
<b>1.50 mm<sup>2</sup> / AWG16</b>	300 m 1000 ft	300 m 1000 ft	150 m 500 ft	75 m 250 ft	30 m 100 ft
<b>1.00 mm<sup>2</sup> / AWG18</b>	300 m 1000 ft	185 m 600 ft	95 m 300 ft	50 m 150 ft	20 m 60 ft
<b>0.75 mm<sup>2</sup> / AWG20</b>	290 m 960 ft	120 m 380 ft	60 m 190 ft	30 m 95 ft	12 m 40 ft

Note The outgoing and return cables may **each** have the indicated length.

### Cable cross section

Use cable cross section suited for **10 A** according to local regulation.

## 10.15 Analog outputs

### Outputs DC 0...10 V

The permissible lengths of the cables between the control outputs and the modulating actuators depend on the type of actuator in use and are calculated as follows:

- A voltage drop of max. 7 % (1.68 V) in the AC 24 V **operating voltage for the actuator**

Reason: to ensure sufficient operating voltage for the actuator.

- A control signal error of max. 1% of the positioning range, due to line resistance in the **signal conductor**.

### Cable length for actuators with AC 24 V supply

The maximum cable length is 300 m / 1000 ft (DXR2: 80 m / 260 ft).

The permissible length of the cables is calculated as follows: Voltage drop of max. 7 % (1.68 V) on the AC 24 V operating voltage for the sensor / actuator.

Cable cross section Power	Cable length				
	2 VA	5 VA	10 VA	20 VA	50 VA
<b>2.50 mm<sup>2</sup> / AWG14</b>	300 m 1000 ft	300 m 1000 ft	235 m 770 ft	120 m 390 ft	47 m 150 ft
<b>1.50 mm<sup>2</sup> / AWG16</b>	300 m 1000 ft	300 m 1000 ft	150 m 500 ft	75 m 250 ft	30 m 100 ft
<b>1.00 mm<sup>2</sup> / AWG18</b>	300 m 1000 ft	185 m 600 ft	95 m 300 ft	50 m 150 ft	20 m 60 ft
<b>0.75 mm<sup>2</sup> / AWG20</b>	290 m 960 ft	120 m 380 ft	60 m 190 ft	30 m 95 ft	12 m 40 ft

Note The outgoing and return cables may **each** have the indicated length.

### Cable length for actuators with AC/DC 24 V supply

These devices have an internal rectifier, to convert AC 24 V to DC 24 V. This causes a DC current to flow in the system neutral conductor (⊥) which causes a voltage drop over the line resistance. This voltage drop falsifies the DC 0...10 V signal value.

**The cable length must be reduced to limit the signal error (1%).**

Cable cross section Power	Cable length				
	1 VA	2 VA	5 VA	10 VA	20 VA
<b>2.50 mm<sup>2</sup> / AWG14</b>	280 m 920 ft	140 m 460 ft	60 m 200 ft	30 m 90 ft	15 m 45 ft
<b>1.50 mm<sup>2</sup> / AWG16</b>	180 m 580 ft	90 m 290 ft	40 m 120 ft	20 m 60 ft	10 m 30 ft
<b>1.00 mm<sup>2</sup> / AWG18</b>	110 m 360 ft	55 m 180 ft	20 m 70 ft	12 m 35 ft	6 m 20 ft
<b>0.75 mm<sup>2</sup> / AWG20</b>	70 m 220 ft	35 m 110 ft	15 m 50 ft	7 m 25 ft	3 m 12 ft

Note The outgoing and return cables may each have the indicated length.

### Current outputs

- The current outputs are non-floating.
- Field devices may be connected in series if
  - they are electrically isolated (floating)
  - the sum of the load resistances and the conductor resistance does not exceed 500 ohms.
- The maximum cable length is 300 m.
- The admissible conductor cross-section depends on the electrical data for the field devices.

### Technical data for analog outputs

	Signal type	Range (under / over range)	Resolution <i>Island bus</i>	Resolution <i>P-Bus BIM</i>	Resolution <i>PROFINET BIM</i>
Output voltage	AO 0-10V	0 ... 10 V (-0.05...10.6 V)	1 mV	11 mV	1 mV
Output current		max. 1 mA			
Output current 1)	AO 4-20mA	4 ... 20 mA (3.92...20.96 mA)	1 µA	1.7 µA	1 µA
Output voltage		ca. DC 15 V			
Load resistance		0 ... 500 Ohm			

1) TXM1.8X and TYM1.8X-ML only, and I/O points 5 ... 8 only)

### Cable length

The permissible cable lengths for the current outputs, the DC 0...10 V control signals and the AC 24 V operating voltage are given in the data sheets of the individual actuators.

- Notes
- Where the actuators are supplied locally with AC 24 V, the control signal cable may be up to 300 m long with a diameter of  $\geq 0.6$  mm.  
**→ The local transformer MUST NOT be earthed (earth loop)!**
  - DC 0...10 V actuators with DC 0...10 V feedback:**  
 System neutral of output and feedback may be in the same conductor due to the small current. However, output and feedback must be on the same I/O module.

The cable lengths for the **current outputs** and the **AC 24 V actuator supply** can be determined by reference to the graph below.

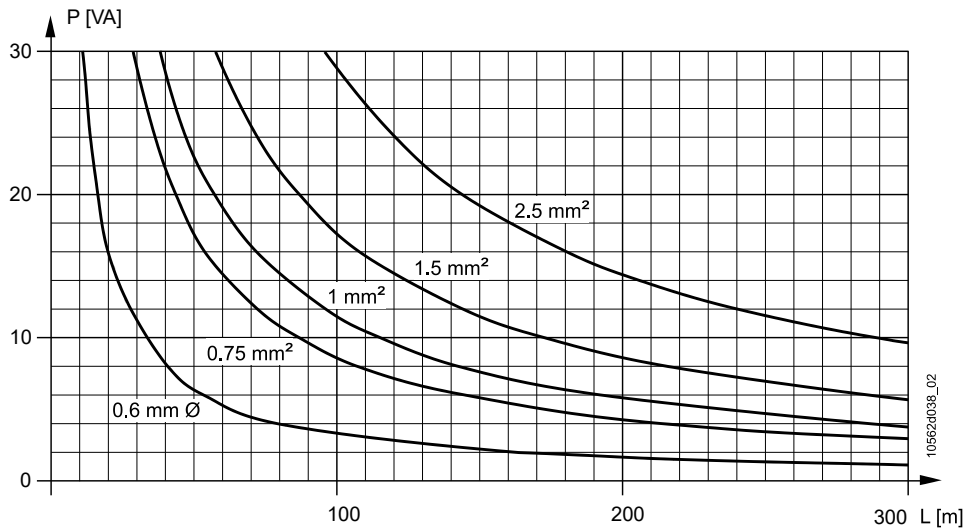

$$\text{Formula: } L = \frac{1.68 \cdot 24 \cdot 57 \cdot A}{2 \cdot P}$$

- Key
- A Cable cross-section [mm<sup>2</sup>]
  - L Permissible cable length [m]
  - P Power consumption of actuator [VA]

Note The outgoing and return cables may **each** have the indicated length.

# 11 Disposal

---

The devices and accessories in the TX-I/O™ range described in this document are manufactured using environment-compatible materials and processes, and optimized to consume as little energy as possible.



This symbol or any other national label indicate that the product, its packaging, and, where applicable, any batteries may not be disposed of as domestic waste. Delete all personal data and dispose of the item(s) at separate collection and recycling facilities in accordance with local and national legislation

See [Siemens disposal information](#) for additional information.

Issued by  
Siemens Switzerland Ltd  
Smart Infrastructure  
Global Headquarters  
Theilerstrasse 1a  
CH-6300 Zug  
Tel. +41 58-724 24 24  
[www.siemens.com/buildingtechnologies](http://www.siemens.com/buildingtechnologies).

© 2007 Siemens Switzerland Ltd  
Technical specifications and availability subject to change without notice