

Electromotoric actuator

SSC161.05UT



For pressure independent zone valves, small globe valves and 3-party valves

- Operating voltage AC/DC 24 V, positioning signal DC 0...10 V
- Self calibrating to the valve stroke
- Direct mounting with coupling nut, no tools required
- Manually override
- Position and actuator motion indication (LED)
- Positioning force 300 N
- Parallel operation of multiple actuators possible

Use

- For zone valves VVP..., VXP..., VMP...: compatible with SSC161.05UT
- For 2-/3-port valves: compatible with SSC161.05UT
- Typically in chilled ceiling, VAV and fan coil unit applications
- Max.10 units of SC161.05UT can operate in parallel, provided the controller output suffices.

Technical design

DC 0...10 V positioning signal

- The valve opens / closes in proportion to the positioning signal at Y.
- At DC 0 V, actuator stem is retracted, the normally closed valve is fully closed.
- When there is no operating voltage, the actuator maintains its current position.
- This actuator provides a DC 0...10 V position feedback signal proportional to the stroke of the actuator stem.

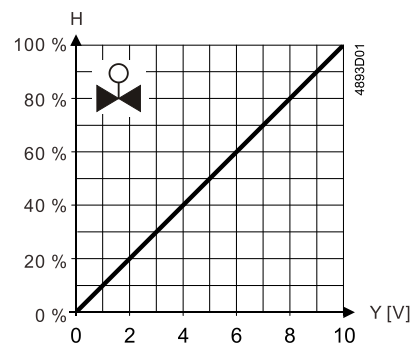

Y = Positioning signal Y [V]

H = Percentage of calibrated valve stroke

LED indication

Status	LED indication patterns
Variants	SSC161.05UT 
Stroke movement: Stem retracting	Flashing green in sequence: LED1-->LED2-->LED3 (500 ms each)
Stroke movement: Stem extending	Flashing green in sequence: LED3-->LED2-->LED1 (500 ms each)
Stem position	At H0 - H40: Constant green (LED3) At H40 - H60: Constant green (LED2) At H60 - H100: Constant green (LED1)
Calibration	Flashing green (LED2): 100 ms on, 100 ms off
Error	Constant red (LED2)
Manual operation	Flashing green/red alternatively (LED2): Green 500 ms, red 500 ms

Type summary

Type	Stock number	Operating voltage	Running speed	Running time 5.5 mm	Positioning signal	Actuator characteristic
SSC161.05UT	S55180-A149	AC/DC 24 V	5 s/mm	27.5 s ± 25 %	DC 0...10 V	Linear

Ordering

When ordering, specify both type and quantity.

Example:

Type	Stock number	Designation	Quantity
SSC161.05UT	S55180-A149	Electromotoric actuator	2

Delivery

Valves and actuators must be ordered separately. For easier valve assembly, actuators ordered separately have the actuator stem fully retracted.

The cable gland is not within the scope of delivery and needs to be ordered separately.

Equipment combinations

Combinable valves

Type reference	Valve type	K _{vs} [m ³ /h]	PN class	Data sheet
VVP45..	2-port valves	0.25...25	PN 16	N4845
VXP45..	3-port valves			
VMP45..	3-port valves with T-bypass			
VVG45.. ¹⁾	2-port valves	0.63...25		Retrofitting to former Landis & Gyr valves
VXG45.. ¹⁾	3-port valves			
X3i.. ¹⁾	3-port valves	0.7...14		

¹⁾With ASK30 mounting kit

Note: To ensure trouble-free operation of third-party valves with the actuator, the valves must satisfy the following requirements:

- Threaded connections with coupling nut: $\frac{3}{4}$ "
- Nominal force: > 300 N
- Dimension X \geq 8.8 mm
- Dimension Y \leq 14.3 mm

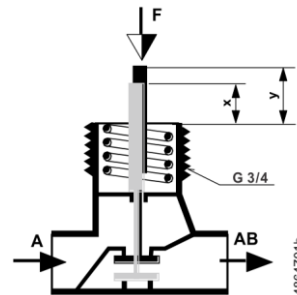

Controllers

Type	AC/DC 24 V; DC 0...10 V
DXR2	DXR2..
RXB..	RXB39.1..

Combinable room thermostats

Type	Detail
RDG..	RDG160KN, RDG160T, RDG260, RDG405KN
RDU..	RDU340
RCU..	RCU50..

Product documentation

Topic	Title	Document ID
Mounting and installation	Mounting instructions	A6V13463377
Standards and directives	CE declarations	A5W00254962A
	RCM conformity	A5W00254983A
Environmental compatibility	Environmental declarations	A5W00244689A

Related documents such as the environmental declarations, declarations of conformity, etc., can be downloaded from the following Internet address:

www.siemens.com/bt/download

Notes

Engineering

The actuators must be electrically connected in accordance with local regulations (see "Connection diagram [▶ 13]").

CAUTION



National safety regulations

Failure to comply with national safety regulations may result in personal injury and property damage.

- Observe national provisions and comply with the appropriate safety regulations.

Observe permissible temperatures (see "Technical data [▶ 10]").

Mounting

WARNING



- Do not use pipe wrenches, pliers or similar tools.
- Avoid lateral pressure or (cable) tension on the mounted actuator!

Valve and actuator are easy to assemble on site before commissioning:

- Remove protective cover from the valve body.
- Position the actuator and tighten the connection nut manually.
- See "Mounting instruction" for graphical instructions.

Orientation

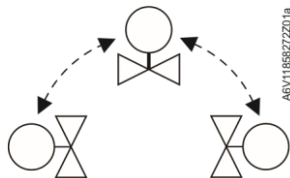

Installation

	A [mm]	B [mm]	C [mm]
	5.5	6.0	35
Crimp ferrule on stripped wire of connecting cable.			

- Observe all admissible temperatures (see "Technical data [► 10]").
- Do not twist the cable.
- Magnets can damage the actuator.
- Provide a means for isolation from the power supply, e.g., connecting a circuit breaker or switch fuse upstream of the control unit.

⚠ CAUTION



National safety regulations

Failure to comply with national safety regulations may result in personal injury and property damage.

- Observe national provisions and comply with the appropriate safety regulations.

⚠ CAUTION



Phase cut and pulse-duration-modulated (PDM) signals are not suitable. Regulations and requirements to ensure the safety of people and property must be observed at all times!

Commissioning

When commissioning, check both wiring and functioning of the actuator.

- Actuator stem extends Normally open valve closes, normally closed valve opens
- Actuator stem retracts Normally open valve opens, normally closed valve closes

NOTICE



The actuator must be commissioned only with a correctly mounted valve in place!

Self-calibration

When operating voltage is applied, the actuator self-calibrates (fully retracted → fully extended → setpoint).

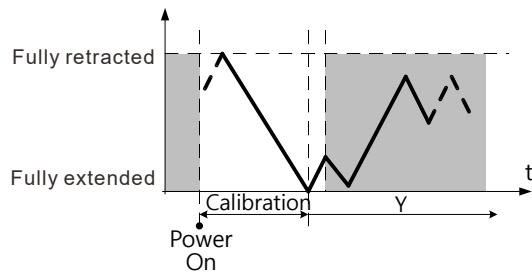

⚠ CAUTION



Never intervene manually during self-calibration.

NOTICE



- Correct calibration is only possible with valve stroke > 1.2 mm. Valve stroke < 1.2 mm results in calibration failure.
- If calibration fails, the actuator performs another calibration automatically after 10 seconds.
- After three failed calibration attempts, the actuator stem remains in the extended position and the valves are open.

Manual operation

A 3-mm Allen wrench can be used to move the actuator to any position.

To move the actuator stem manually

1. Open the cover using a proper screwdriver.
2. Press and hold down button (a) illustrated below for at least three seconds.
 - The actuator ignores any positioning signal from the controller.
3. Adjust the position of the actuator stem by rotating Allen wrench (b) illustrated below clockwise or anti-clockwise.
 - The actuator stem moves down if you rotate clockwise; it moves up if you rotate anti-clockwise. The manually set position is retained.
4. To exit manual operation mode, press and hold down button (a) illustrated below again for at least three seconds.
 - The actuator runs a self-calibration automatically. Positioning signal sent from the controller takes effect.
5. Close the cover.

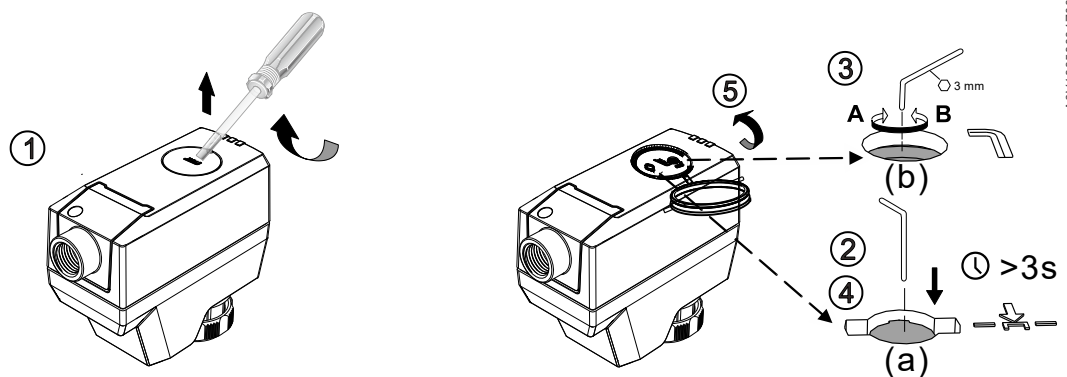

NOTICE



If operating voltage is applied to actuator, press button (a) before and after manually adjusting the position of the actuator stem. If no operating voltage and positioning signal are applied, manual operation can be done without pressing button (a).

Cabling operation

1. Unscrew cover screw
2. Remove cover
3. Connect or disconnect wire terminals
4. Install the cover
5. Screw in the cover screw

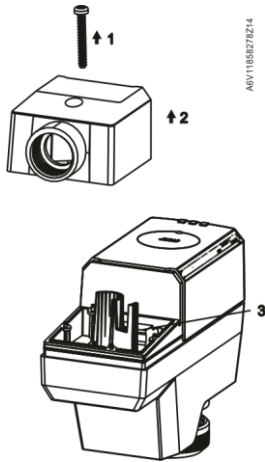

Maintenance

The actuators require no maintenance.

⚠ WARNING



Operating voltage must be switched off during any maintenance!

NOTICE



When carrying out service work on the plant, note the following:

- Switch off operating voltage.
- If necessary, disconnect electrical connections from the terminals.
- The actuator must be commissioned only with a correctly mounted valve in place!

Disposal



The device is considered an electronic device for disposal in accordance with European guidelines and may not be disposed of as domestic waste.

- Dispose of the device through channels provided for this purpose.
- Comply with all local and currently applicable laws and regulations.

Warranty

Technical data on specific applications are valid only together with Siemens products listed under "Equipment combinations". Siemens rejects any and all warranties in the event that third-party products are used.

Software license overview

These devices use Open Source Software (OSS). All Open Source Software components used in the product (to include copyrights and licensing agreement) are available at <http://siemens.com/bt/download>.

Firmware version	OSS document		Device
	Document ID	Title	
2.10.0 or above	A6V13503690	Readme OSS for Modulating Room Actuator 200N, 300N	All

Power supply	
Operating voltage	AC 24 V (± 15 %) or DC 24 V (± 20 %)
Frequency	50/60 Hz
Power consumption	3.5 VA
Primary fuse or breaker rating	External, 2 A quick blow

Signal input	
Positioning signal	DC 0...10 V to Y
Input impedance	100 kOhm
Parallel operation (number of actuators)	Max. 10 ¹⁾

1) Provided that the controller output is sufficient.

Signal output	
Feedback signal	DC 0...10 V
Max. output current	1 mA
Max. output voltage	-
Resolution	1:100

Operating data	
Position with de-energized contact Y	See "Technical design [▶ 2]"
Running speed	5 s/mm ± 25 %
Positioning force	300 N
Stroke	1.2...6.5 mm
Permissible temperature of medium in the connected valve	1...120 °C

Electrical connection (connecting cable integral)	
Permissible length for signal lines	<20 m
Wire cross section	0.5...0.75 mm ²
Cable diameter	<5.5 mm

Mounting	
Connection to valve	Brass coupling nut ¾" inch
Orientation	360°

Standards	
EU conformity (CE)	A5W00254962A
RCM conformity	A5W00254983A
UKCA	A5W00257055A
Housing protection degree	IP 54
Protection class according to EN 60730	III
Pollution degree	2
Overvoltage category	III
Environmental compatibility	The product environmental declaration (A5W00244689A) contains data on environmentally compatible product design and assessments (RoHS compliance, materials composition, packaging, environmental benefit, disposal).
UL Approval	UL as per UL60730-1, UL60730-2-14 http://ul.com/database
Federal Communications Commission	cUL as per CSA – CAN E60730-1, E730-2-14 FCC CFR 47 Part 15 Class B
ICES003	CAN ICES-3 (B)/NMB-3(B)

FCC regulations

Modification of this device to receive cellular radio telephone service signals is prohibited under FCC rules and federal law.

This equipment has been tested and found to comply with the limits for a Class B digital device, pursuant to part 15 of the FCC Rules. These limits are designed to provide reasonable protection against harmful interference in a residential installation. This equipment generates, uses and can radiate radio frequency energy and, if not installed and used in accordance with the instructions, may cause harmful interference to radio communications. However, there is no guarantee that interference will not occur in a particular installation. If this equipment does cause harmful interference to radio or television reception, which can be determined by turning the equipment off and on, the user is encouraged to try to correct the interference by one or more of the following measures:

Reorient or relocate the receiving antenna.

Increase the separation between the equipment and receiver.

Connect the equipment into an outlet on a circuit different from that to which the receiver is connected.

Consult the dealer or an experienced radio/TV technician for help.

Changes or modifications not expressly approved by the party responsible for compliance could void the user's authority to operate the equipment.

Statement

This device complies with part 15 of the FCC Rules. Operation is subject to the following two conditions: (1) This device may not cause harmful interference, and (2) this device must accept any interference received, including interference that may cause undesired operation.

Housing color	
Cover/base	2003, Ti-Gray
Coupling nut	Metal

General ambient conditions			
	Operation	Transport	Storage
Temperature	1...50 °C	-25...70 °C	-25...70 °C
Humidity	5...95 % r.h. non condensing	<95 % r.h. non condensing	5...95 % r.h. non condensing
Atmospheric pressure	Min. 700 hPa, corresponding to max. 3,000 m above sea level	-	-

Material	
Cover/base	PC + ABS

Weight
280 g

Connection terminals

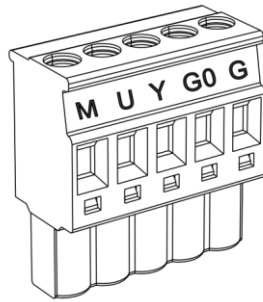

- G System potential (AC/DC 24 V)
- G0 System neutral
- Y Positioning signal DC 0...10 V
- U Feedback signal
- M Measurement reference

Connection diagram

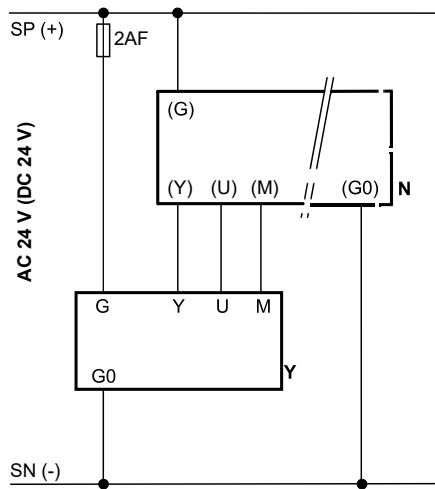

- N** = Controller
- SP, G** = System potential AC 24 V
- SN, G0** = System neutral
- Y** = Positioning signal
- U** = Feedback signal
- M** = Measurement reference

Dimensions

mm

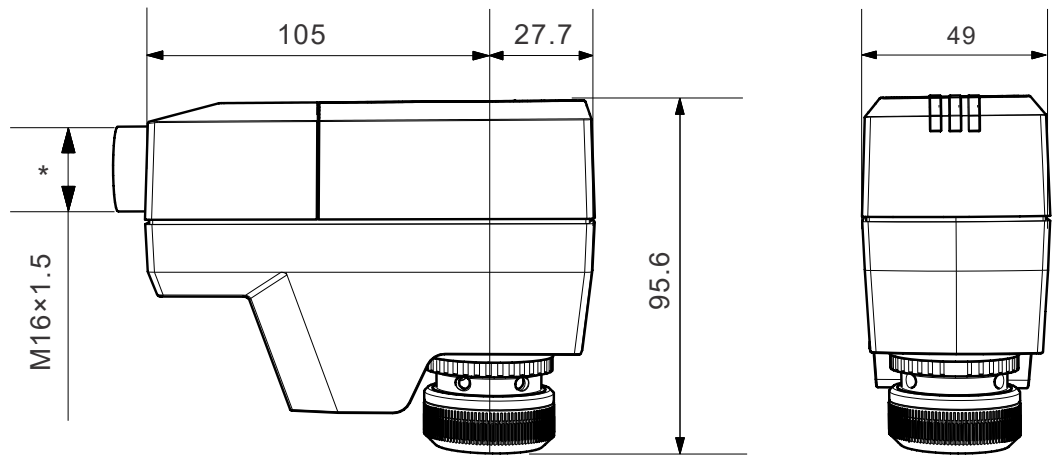

*: The maximum cable gland thread length is 11 mm.

Revision numbers

Type	Valid from rev. no.
SSC161.05UT	..A

Issued by
Siemens Switzerland Ltd
Smart Infrastructure
Global Headquarters
Theilerstrasse 1a
CH-6300 Zug
+41 58 724 2424
www.siemens.com/buildingtechnologies

© Siemens 2023
Technical specifications and availability subject to change without notice.

Document ID A6V13359035_en--_d
Edition 2023-11-24