

SIEMENS



BT300 Demonstration Panel Operator's Manual

Copyright Notice

Notice

Document information is subject to change without notice by Siemens Industry, Inc. Companies, names, and various data used in examples are fictitious unless otherwise noted. No part of this document may be reproduced or transmitted in any form or by any means, electronic or mechanical, for any purpose, without the express written permission of Siemens Industry, Inc.

All software described in this document is furnished under a license agreement and may be used or copied only in accordance with license terms.

For further information, contact your nearest Siemens Industry, Inc. representative.

Copyright 2014 by Siemens Industry, Inc.

To the Reader

Your feedback is important to us. If you have comments about this manual, please submit them to: SBT_technical.editor.us.sbt@siemens.com

Product or company names mentioned herein are the trademarks of their respective owners.

Printed in USA

Table of Contents

How to Use This Manual	5
About This Manual.....	5
Document Organization.....	5
Getting Help.....	5
Reference Documents	6
Demonstration Panel Overview	7
General Description.....	7
Operation Overview.....	11
Configuration - Drive Only.....	12
Configuration - Electronic Bypass	13
Key Procedures	16
Factory Reset Procedure.....	16
Startup Wizard.....	16
Bypass Wizard.....	16
Communications Configuration	16
Wiring Diagrams	17
Operation	19
Demonstration Configurations	20
VFD Only.....	20
Electronic Bypass	21
Bypass Operation	24
Drive Mode - Auto.....	24
Drive Mode - Hand	25
OFF Mode	26
Bypass Mode.....	26
Diagnostic Board	28
Diagnostic Board	28
Test Points.....	29
Electronics Override	31
Demonstration Steps	32
VFD Demo Mode.....	32
Bypass Demo Mode	34
Training Exercises	37
Exercise 1	37
Exercise 2	38
Exercise 3	38
Exercise 4	39

Exercise 540
Exercise 640
Other Functions to Test41
Exercise Answers/Information42
 Exercise 142
 Exercise 243
 Exercise 344
 Exercise 445
 Exercise 545
 Exercise 646

How to Use This Manual

About This Manual

This manual is written for the Owner and User of the Siemens BT300 Demonstration Panel. It is designed to help you become familiar with the Siemens BT300 Demonstration Panel and its applications.

This section covers document organization, how to access help, related publications, and any other information that will help you use this manual.

Document Organization

This manual contains the following sections:

- **Reference Documents** - provides a list of the related documents that are referenced or could be referenced while using the BT300 Demonstration Panel.
- **Demonstration Panel Overview** - describes the BT300 Demonstration Panel.
- **Key Procedures** - describes the key procedures used and where to find those procedures.
- **Wiring Diagrams** - provides necessary diagrams for power and control wiring of the Demonstration Panel.
- **Operation** - describes the use of the Demonstration Panel.
- **Demonstration Configurations** - describes the different modes that the BT300 Demonstration Panel can be configured for.
- **Diagnostic Board** - describes the panel's troubleshooting diagnostic board and its test points..
- **Training Exercises** - provides exercises and guidelines for training on how to use BT300 Drives.

Getting Help

For more information about BT300 products, contact our local Siemens Industry representative.

Reference Documents

The following documentation is available from your local Siemens Industry, Inc. representative:

- *BT300 Variable Frequency Drive Bypass Installation Instructions* (DPD01375), provide installation instructions for the Siemens BT300 Bypass.
- *BT300 Variable Frequency Drive Installation Manual* (DPD01148), provides installation instructions for the BT300 HVAC Variable Speed Drive.
- *Siemens BT300 HVAC Drive Operator's Manual* (DPD01149), provides operating instructions and procedures for the BT300 Drive.
- *BT300 Variable Frequency Drive Bypass Operator's Manual* (DPD01391), provides operating instructions for the BT300 HVAC Variable Speed Drive with Bypass.
- *BT300 VFD Submittal Sheet* (154-126), provides a synopsis of the BT300 Drive product line, accessories, and technical data.
- *BT300 HVAC Drives Conventional Bypass (C-Bypass) Options Submittal Sheet* (154-128), provides a comprehensive overview of the BT300 Conventional Bypass.
- *BT300 HVAC Drives Electronic Bypass (E-Bypass) Options Submittal Sheet* (154-129), provides a comprehensive overview of the BT300 Electronic Bypass.
- *Siemens BT300 I/O Option Boards User's Manual* (DPD01158), provides installation instructions and technical information for the wide selection of expander boards that are available for the BT300 Drive.
- *Siemens BT300 HVAC Drive Protocol Installation and User's Manual* (DPD01162) discusses the various network protocols supported by the BT300 Drive and instructions for connecting to a network.

Demonstration Panel Overview

General Description

The BT300 Variable Frequency Drive and Bypass Demonstration Panel can be used to demonstrate the features and functions of the stand alone drive as well as the electronic bypass.



Figure 1: BT300 Demonstration Panel

The BT300 VFD comes with standard I/O that consists of two analog inputs, one analog output, six digital inputs and three relay outputs. This I/O (shown in Figure 2) has been wired to the demo unit (shown in Figure 7).

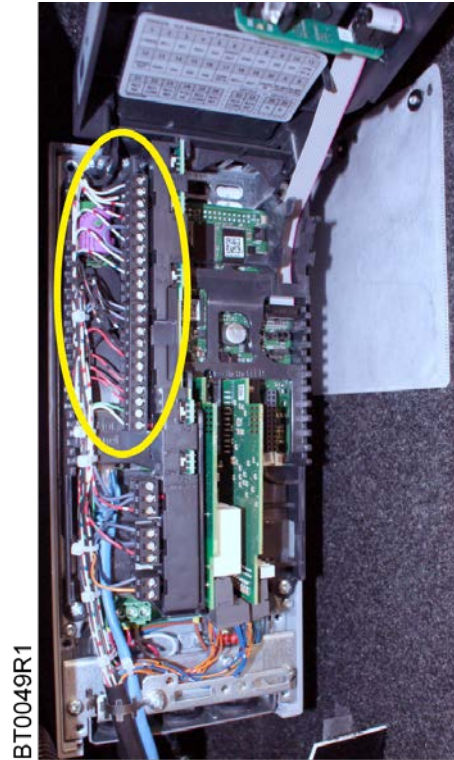

Figure 2: Standard I/O.

Additional I/O can be added to the BT300 and there is a variety of expansion boards available. The Demonstration Panel has two expansion boards installed; one is the BT300-OPT-B5-V Board (as shown in Figure 3). This is a three-relay output expansion board that is used in all electronic bypass option units for control of the contactors.

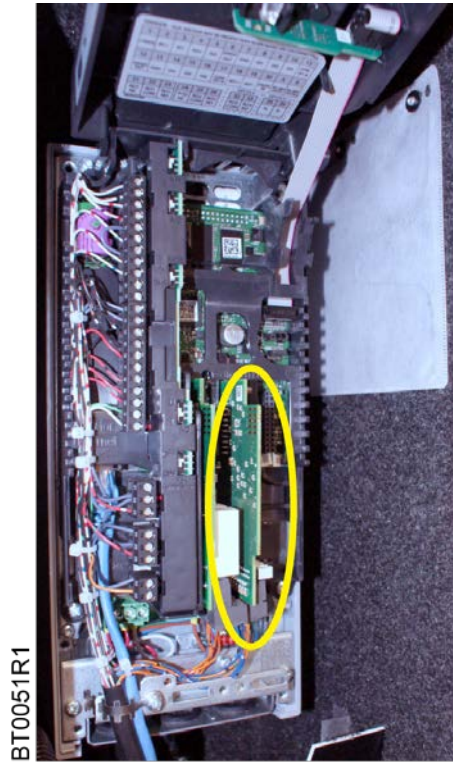

Figure 3: OPT-B1-V I/O Board - Expansion Slot D.

The second expansion board installed is the BT300-OPT-B1-V (as shown in Figure 4) which contains six bi-directional terminals; however, these have all been wired as digital inputs in the demonstration unit. These are completely programmable in the Demonstration Panel as the User requires.

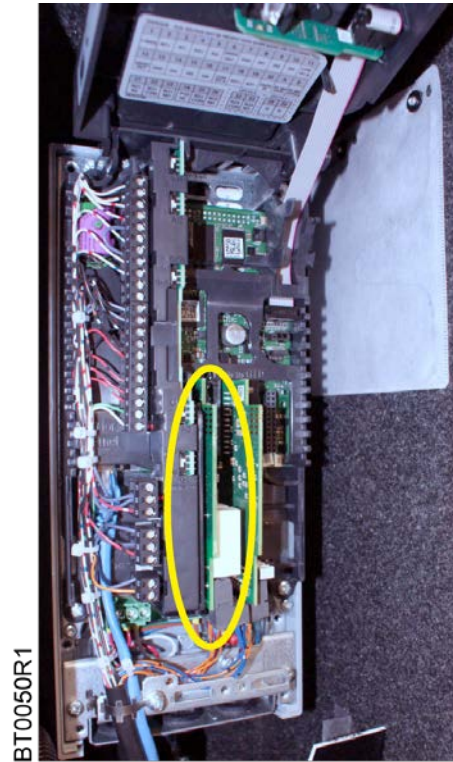

Figure 4: OPT-B5-V I/O Board - Expansion Slot C.

The Demonstration Panel enclosure contains the following equipment:

Power Cord

- Software Interface Cable (BT300-CABLE)
- CD (containing all documentation listed in the Reference Documents section of this manual)
- Printed copy of this manual
- Foam insert (used for shipping only)

The Demonstration Panel enclosure contains controls that include the following:

- Control terminals
- Step-up control transformer
- Contactors:
 - Bypass (M1)
 - Output (M2)
 - Service Switch (M3)
- Overload (current) relay (simulated)
- Disconnect Switch
- Mode Switch
- Diagnostics board

Operation Overview

The Demonstration Panel is shipped with a foam insert located above the BT300 Drive. This must be removed before the unit is powered up. It must also be inserted before the unit is closed up for shipping.

The Demonstration Panel is powered using the provided power cord that is connected to the rear of the demo unit and to a standard 110/115 Vac outlet.

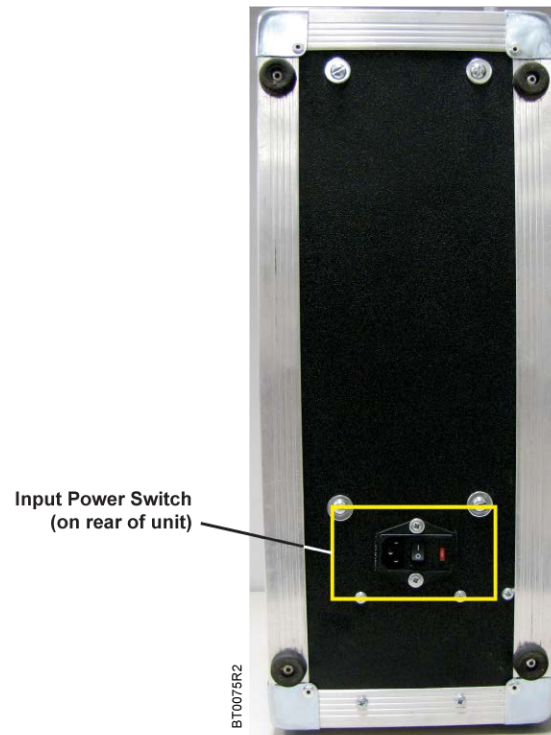

Figure 5: Demonstration Panel Power Cord.

The Demonstration Panel can be set into two different operating modes, one is for VFD-only demonstrations, and the other is for VFD with Electronic Bypass demonstrations. The mode selection switch is located below the drive on the right hand side of the Demonstration Panel. This mode switch will put the contactors into the proper position when the bypass option is not used.

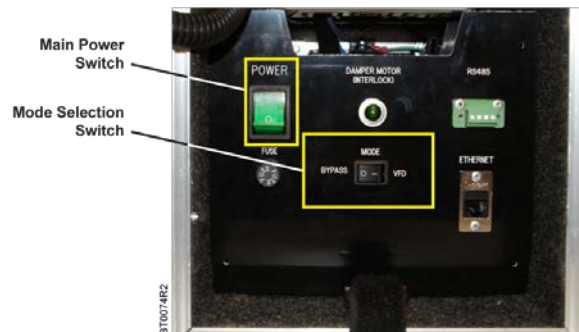

Figure 6: Demonstration Panel Mode Switch.

Configuration - Drive Only

The BT300 Variable Frequency Drive and Bypass Demonstration Panel can be used to demonstrate the features and functions of the stand alone BT300 Drive. When used in this manner, the Service Switch (M3) must be turned on, and, the Mode Switch must be in the **VFD** position to allow the motor to operate.

The BT300-OPT-B1-V I/O expansion board is installed in the unit. There is no default programming associated to this I/O card. It can be freely mapped. However, all six DIOs have been wired as digital inputs only.

The VFD only configuration uses the following I/O default values (after a factory reset):

I/O Default Value	Description
DI1	Start Forward
DI2	Start Reverse
DI3	External Fault
DI4	Preset Freq 1
DI5	Preset Freq 2
DI6	Fault Reset
AI1	0 to 10 Vdc
AI2	4 to 20 mA
RO1	Run
RO2	Fault
RO3	Ready
AO1	Output Frequency

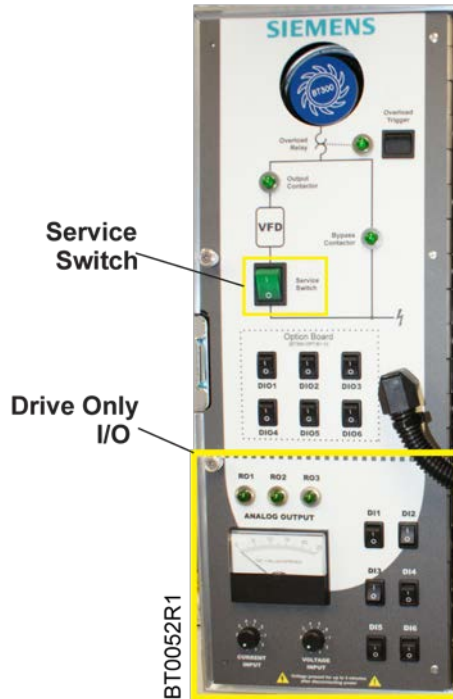

Figure 7: Drive Only Interface and Service Switch.

Configuration - Electronic Bypass

The BT300 Variable Frequency Drive and Bypass Demonstration Panel can be used to demonstrate the features and functions of the electronic bypass and its features. When used in this manner, the M3 contactor switch must be turned on, and the Mode Switch must be in the **BYPASS** position for proper operation.

The BT300-OPT-B1-V I/O expansion board is installed in the unit. There is no default programming associated to this I/O card. It can be freely mapped. However, all six DI0s have been wired as digital inputs only.

The Electronic Bypass uses the following I/O default values (after Bypass Wizard use):

Standard I/O Default Value	Description
DI1	Start Forward
DI2	Remote Safety 1
DI3	Remote Safety 2
DI4	Interlock (Feedback) *
DI5	Overload
DI6	Essential Services *
AI1	0 to 10 Vdc
AI2	4 to 20 mA
RO1	Run

Standard I/O Default Value	Description
RO2	Fault
RO3	Ready
AO1	Output Frequency
* If option is enabled.	

BT300-OPT-B5-V Default Value	Description
RO1	Bypass (M1)
RO2	Output (M2)
RO3	Interlock (Command)



Contact closure is required on any digital input that is defined as a Remote Safety.

If a contact closure occurs on the digital input defined for Overload, all Drive operations will cease and the motor will not run.

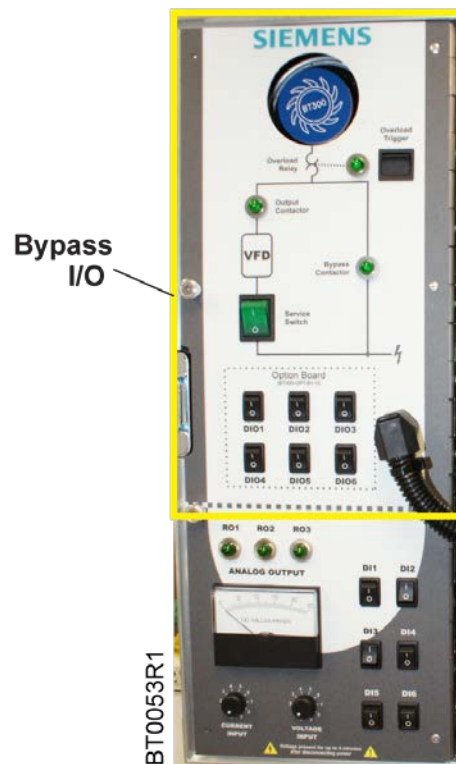

Figure 8: Bypass I/O Interface.

Electronic Bypass Configuration Notes:

- A jumper between Terminals 3 and 4 of the diagnostics board (pre-installed) is required. On the BT300 Demonstration Panel, this is wired to an SPST toggle switch for convenience. The switch is labeled **Override Safety** and is mounted to the left of the diagnostic board.
- The Drive should be factory reset.
- The Bypass Wizard should be run.
- **Drive (Auto or Hand)** will close the output (M2) contactor. The bypass (M1) contactor will be open. The motor will spin in accordance with drive operation.
- **Off** will open the bypass (M1) and output (M2) contactors. The motor will be unable to spin.
- **Bypass** will close the bypass (M1) contactor. The output (M2) contactor will be open. The motor will be connected to utility/line power.

Key Procedures

The detailed procedures can be found in the *BT300 Operator's Manual* (DPD01149) or the *BT300 Bypass Operator's Manual* (DPD01391). This document only covers a few highlights.

Factory Reset Procedure

Navigate to: **User Settings > Parameter Backup > Restore Factory Default > Activate.**

Startup Wizard

This Wizard starts automatically after the unit is factory reset. If required to reactivate the Wizard, navigate to: **Quick Setup > Startup Wizard > Activate.**

Bypass Wizard

The Bypass Wizard helps you to easily commission the Bypass function and features. This Wizard can be started directly from the Startup Wizard. If you must reactivate the Wizard, navigate to: **Quick Setup > Bypass Wizard > Activate.**

The Bypass I/Os are automatically configured based on the mode selected.

Communications Configuration

The BT300 Demonstration Panel has RS-485 and Ethernet connections available for ease of use. The communications configuration is documented in the *Siemens BT300 HVAC Drive Protocol Installation and User's Manual* (DPD01162).

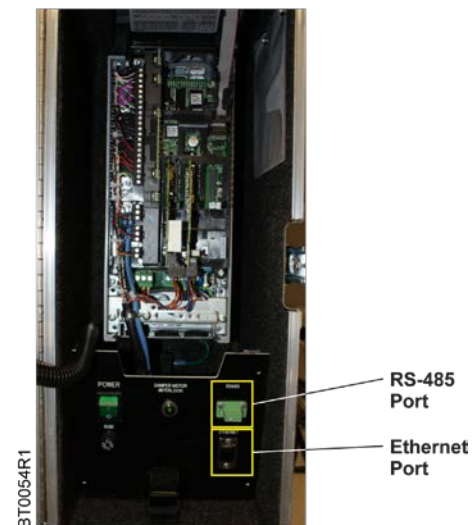

Figure 9: Communications Port Locations.

Wiring Diagrams

ORIGIN	PIN	COLOR	DESTINATION	VOLTAGE
VFD	1	WHT	AI-1	10VDC
	2	WHT/BLK	AI-1	ANLG
	3	WHT/RED	AI-1	ANLG
	4	WHT/BLK/RED	4-20 (-)	24VDC
	5	-	VFD-7	GND
	6	WHT/RED/GRN	4-20 (+)	24VDC
	7	-	VFD-5	GND
	8	WHT/RED/ORG	DI1	24VDC
	9	WHT/RED/BLU	DI2	24VDC
	10	BLK	DI3	24VDC
	11	-	-	-
	12	BLK/WHT	M3-41	24VDC
	12	-	OPTB5-28	24VDC
	13	BLK/RED	J3-10	GND
	13	-	VFD-22	GND
	13	-	VFD-25	GND
	13	BLK	DAMPER	24VDC
	14	BLK/WHT/RED	DI4	24VDC
	15	BLK/GRN/RED	DI5	24VDC
	15	BLK/WHT/ORG	M3-42	24VDC
	16	RED	DI6	24VDC
	17	-	-	-
	18	RED/BLK	METER	ANLG
	19	RED/WHT	METER	ANLG
	30	RED/GRN	J3-7	24VDC
	A	GRN	RS485- (1)	COMM
	B	WHT	RS485+ (2)	COMM
	21	-	-	-
	22	-	VFD-13	GND
	22	-	VFD-25	GND
	23	RED/BLK/WHT	RO1	24VDC
	24	-	VFD-32	GND
	25	-	VFD-13	GND
	25	-	VFD-22	GND
	26	RED/BLK/GRN	RO2	24VDC
	32	-	VFD-24	GND
	33	ORG	RO3	24VDC

ORIGIN	PIN	COLOR	DESTINATION	VOLTAGE
VFD-POWER	L1	RED	SERVICE SW	230VAC
	L1	RED	L2	230VAC
	L2	RED	L1	230VAC
	L3	WHT	SERVICE SW	230VAC
	T1	BRN	M2-33	230VAC
	T2	BLK	M2-13	230VAC
	T3	BLU	M2-23	230VAC

ORIGIN	PIN	COLOR	DESTINATION	VOLTAGE
OPTB5	22	ORG/RED	J3-1	120VAC
	23	ORG/GRN	J3-2	120VAC
	25	ORG/BLK	J3-3	120VAC
	25	RED	MODE SW	120VAC
	26	ORG/BLK/WHT	J3-4	120VAC
	26	BLK	MODE SW	120VAC
	28	-	VFD-12	24VDC
	29	RED	DAMPERS	24VDC

ORIGIN	PIN	COLOR	DESTINATION	VOLTAGE
OPTB1	1	ORG/BLK/GRN	DIO1	24VDC
	2	ORG/BLU/WHT	DIO2	24VDC
	3	BLU	DIO3	24VDC
	4	-	-	-
	5	BLU/WHT	DIO4	24VDC
	6	BLU/BLK	DIO5	24VDC
	7	BLU/RED	DIO6	24VDC
	8	-	-	-
	9	-	-	-
	10	BLU/BLK/WHT	DIO 1-6	24VDC

ORIGIN	PIN	COLOR	DESTINATION	VOLTAGE
RELAY BOARD	J2-1	BLK	M2-44	120VAC
	J2-2	RED	M3-A1	120VAC
	J2-3	BLU	M3-33	120VAC
	J2-4	ORG	M3-34	120VAC
	J2-5	YLW	M1-A1	120VAC
	J2-6	BRN	M2-A1	120VAC
	J2-7	-	-	-
	J2-8	BLU/BLK	M1-A2	120VAC
	J2-9	ORG/BLK	M2-A2	120VAC
	J2-10	-	-	-
	J2-11	-	-	-
	J2-12	GRN	GND	GND
	J3-1	ORG/RED	OPTB5-22	120VAC
	J3-2	ORG/GRN	OPTB5-23	120VAC
	J3-3	ORG/BLK	OPTB5-25	120VAC
	J3-4	ORG/BLK/WHT	OPTB5-26	120VAC
	J4-5	-	-	-
	J3-6	-	-	-
	J3-7	RED/GRN	VFD-30	24VDC
	J3-8	-	-	-
	J3-9	-	-	-
	J3-10	BLK/RED	VFD-13	GND
	J5-1	GRN	DC-PS-L	120VAC
	J5-2	GRN/BLK	DC-PS-N	12VAC
	J5-3	GRN/WHT	DC-PS-G	GND
	J5-4	GRN/BLK/ORG	DC-PS-0V	24VDC
	J5-5	GRN/BLK/WHT	DC-PS-+24V	24VDC
	J5-6	-	-	-

BT0071R1

Figure 10: Wiring Terminations.

RS-485 Pinouts	
Pin Number	Description
1	VFD Terminal A/RS-485 Data -
2	VFD Terminal B/RS-485 Data +
3	Not Used
4	Not Used

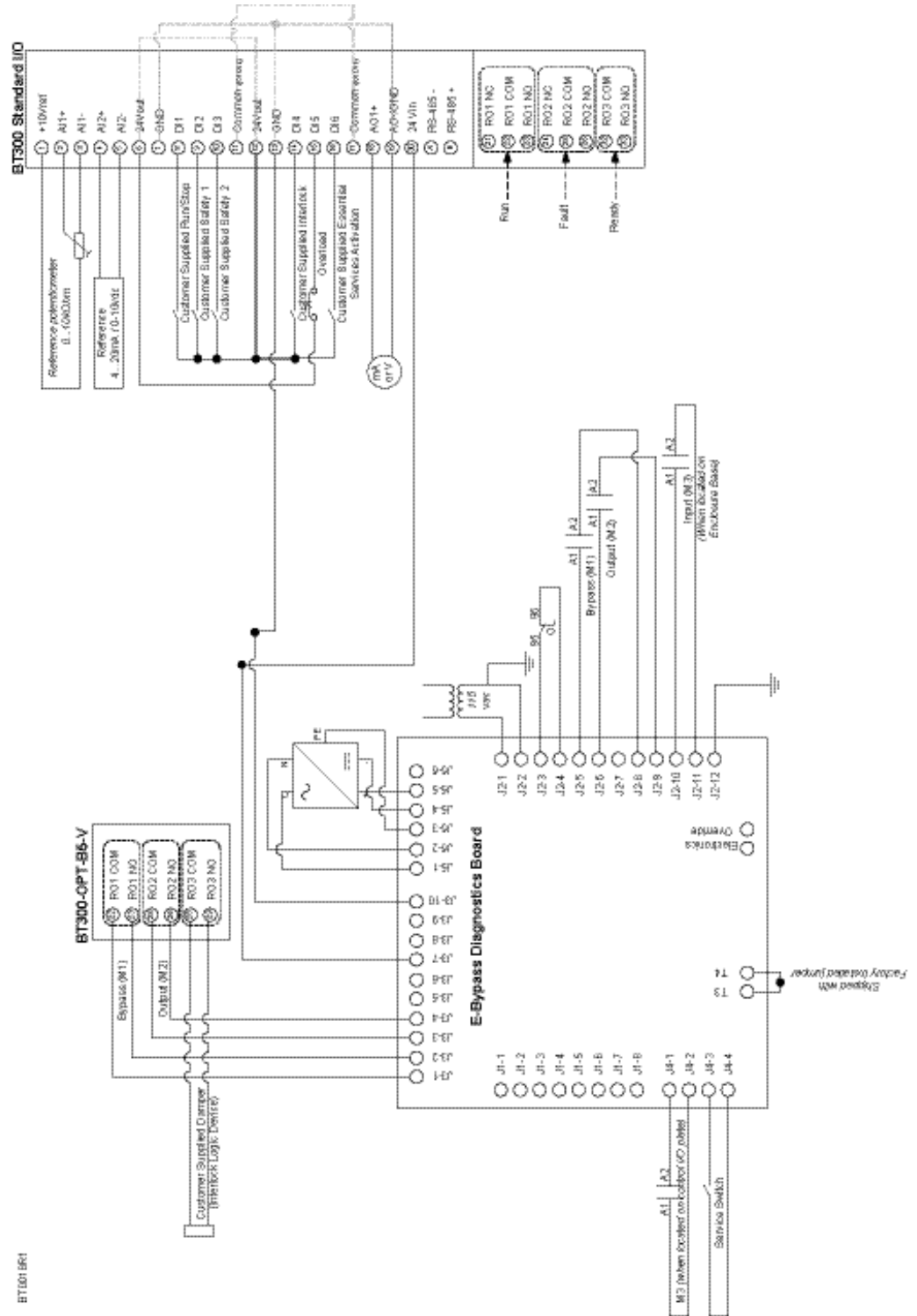



Figure 11: Electronic Bypass Drive Terminations.

Operation

The drive mode goes into Drive mode when powered up. In this mode, the drive can be controlled normally from Auto or Hand control place. In the Drive mode, the **Bypass Running** relay output signal is off and the drive's output contactor is energized by closing the relay RO2 on the OPT-B5 board. The bypass contactor is open. A relay output signal **Drive Active** is on when the drive is in Drive mode.

The Drive mode can be entered from the Bypass mode by pressing the **Hand/Auto** button  and selecting either **Hand** or **Auto** behind the **Drive** menu.

Mode of operation is the same in both the Conventional and Electronic Bypasses. However, there are different methods for determining the modes. The procedures in this section are used to change operational modes.

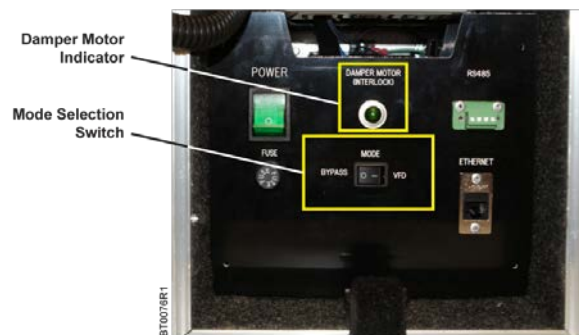

Figure 12: Demonstration Panel Mode Switch.

Demonstration Configurations

VFD Only

The BT300 Demonstration Panel can be used to demonstrate the features and functions of the stand-alone BT300 Drive. When used in this manner, the Service Switch (M3) must be turned on for proper operation, and, the Mode Switch must be in the VFD position to allow the motor to operate.

The VFD Only configuration uses the following I/O default values (after a factory reset):

I/O Default Value	Description
DI1	Start Forward
DI2	Start Reverse
DI3	External Fault
DI4	Preset Freq 1
DI5	Preset Freq 2
DI6	Fault Reset
AI1	0 to 10 Vdc
AI2	4 to 20 mA
RO1	Run
RO2	Fault
RO3	Ready
AO1	Output Frequency

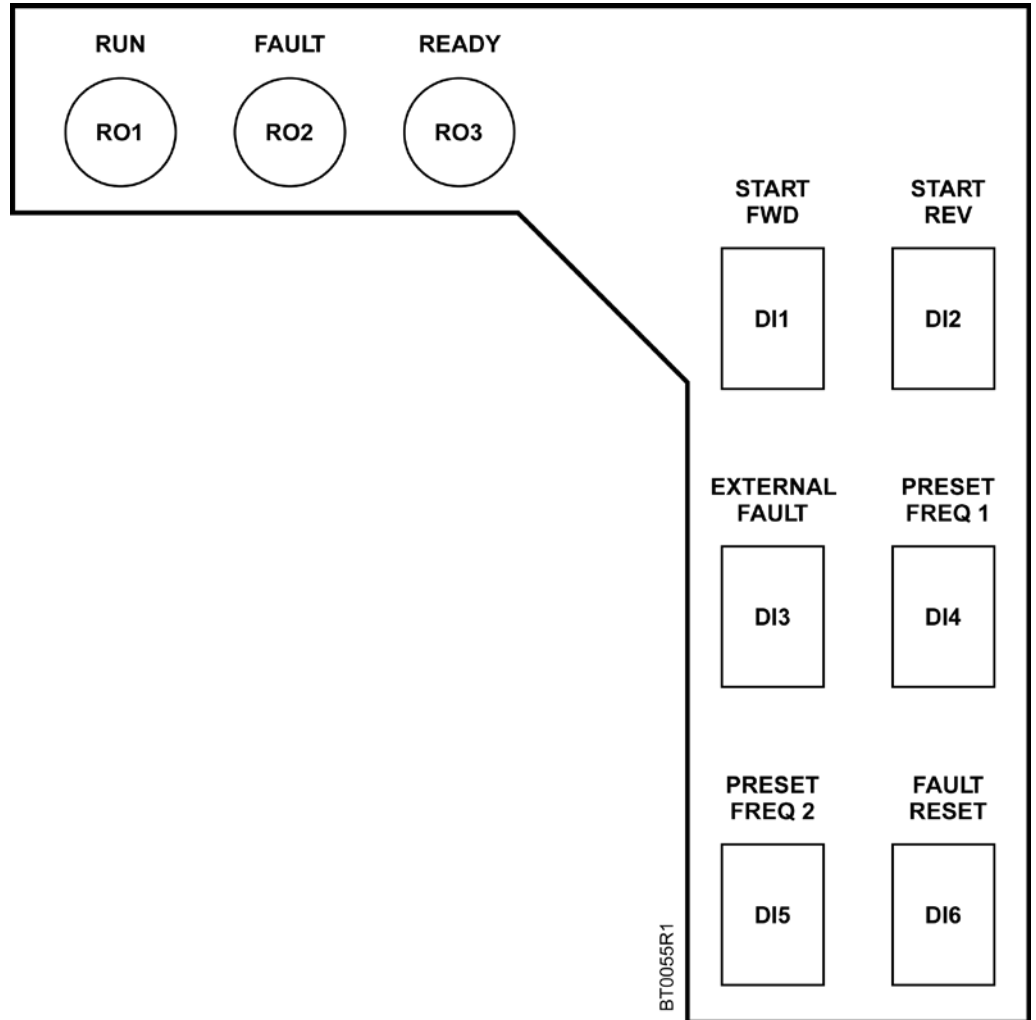

Figure 13: VFD Only Default Overlay.

Electronic Bypass

This unit can be used to demonstrate the electronic bypass feature operation. When used in this manner, the M3 contactor switch must be turned on, and the Mode Switch must be in the **BYPASS** position for proper operation.

The electronic bypass uses the following I/O default values (after bypass wizard use):

Standard I/O Default Value	Description
DI1	Start Forward
DI2	Remote Safety 1
DI3	Remote Safety 2
DI4	Interlock (Feedback) *
DI5	Overload

Standard I/O Default Value	Description
DI6	Essential Services *
AI1	0 to 10 Vdc
AI2	4 to 20 mA
RO1	Run
RO2	Fault
RO3	Ready
AO1	Output Frequency
* If option is enabled.	

BT300-OPT-B1-V Default Value	Description
DIO1	User Defined
DIO2	User Defined
DIO3	User Defined
DIO4	User Defined
DIO5	User Defined
DIO6	User Defined

BT300-OPT-B5-V Default Value	Description
RO1	Bypass (M1)
RO2	Output (M2)
RO3	Interlock (Command)

It is required to have contact closure on any digital input that is defined as a Remote Safety.

If a contact closure occurs on the digital input defined for Overload, all drive operations cease and the motor does not run.



Contact closure is required on any digital input that is defined as a Remote Safety.

If a contact closure occurs on the digital input defined for Overload, all Drive operations cease and the motor does not run.

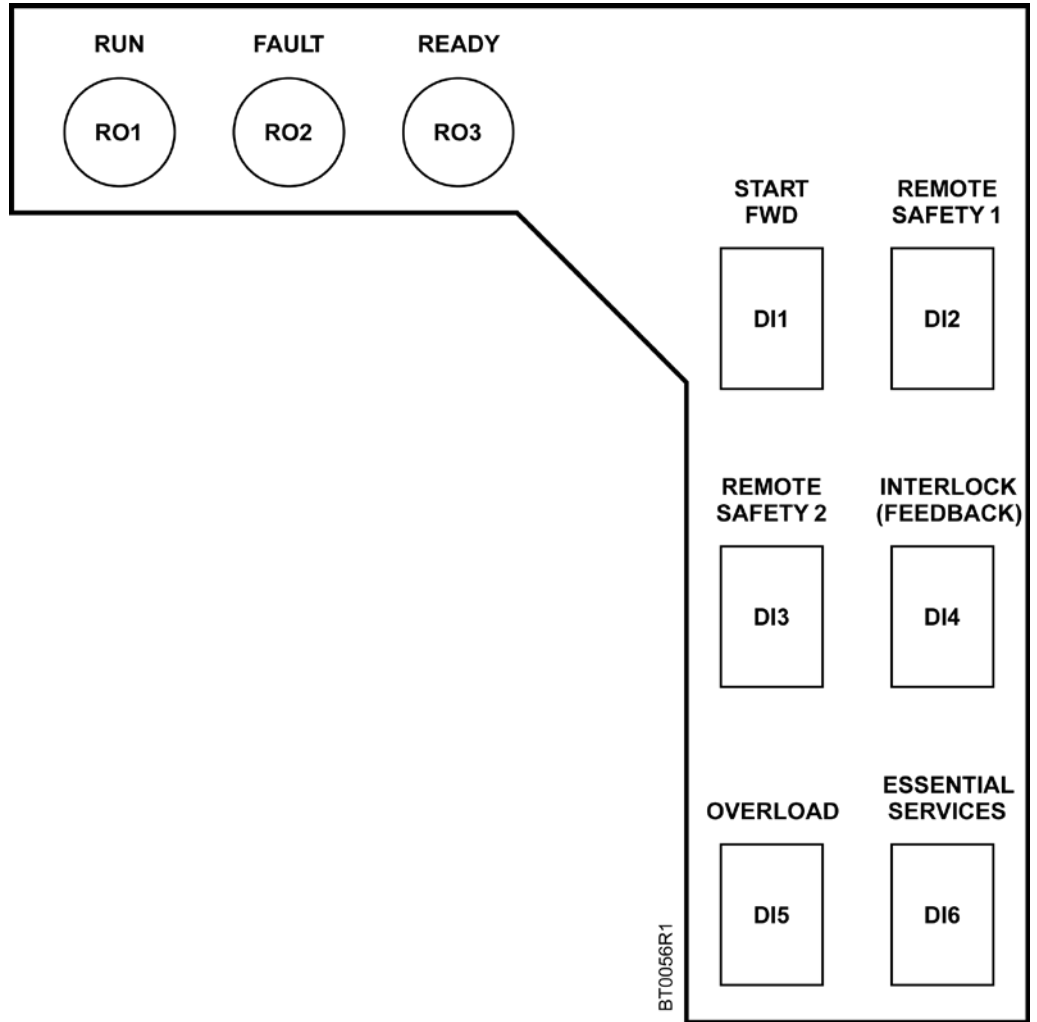

Figure 14: Bypass Overlay 1.

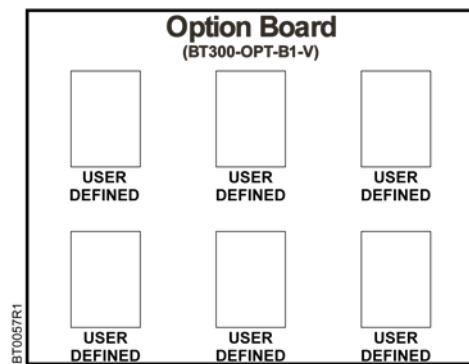

Figure 15: Bypass Overlay 2.

Bypass Operation



Drive Mode - Auto

Auto mode is the default mode of operation.

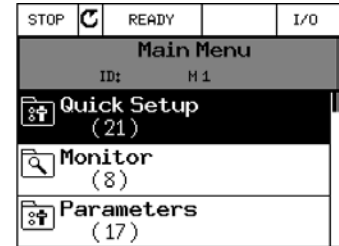

- This mode is used when the drive will control the motor, and the drive is used with an automation system.
- In Auto mode, the Bypass (M1) contactor is opened and the Output (M2) contactor is closed.

1. At the drive keypad, press the **Hand/Auto** button



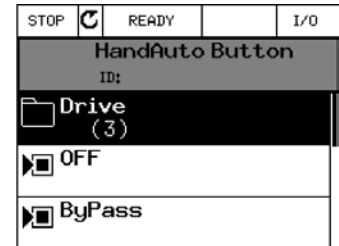

2. Use the **Up** and/or **Down Arrow** buttons   to highlight **Drive**, then press **OK** .



3. Use the **Up** and/or **Down Arrow** buttons   to highlight **Auto**, then press **OK** .



4. Use the **Up** and/or **Down Arrow** buttons   to highlight **Activate**, then press **OK** .

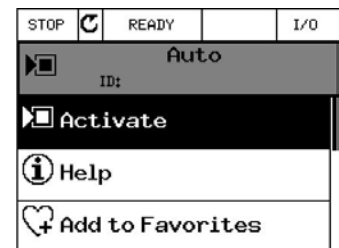

The unit is now operating in the Drive mode using I/O or Fieldbus control. The display will return to the default display.

Drive Mode - Hand

Hand mode overrides the automation system and runs the drive in Keypad mode.

- The User has full control to start/stop the motor, and change the speed reference directly from the keypad.
- In Hand mode, the Bypass (M1) contactor is opened and the Output (M2) contactor is closed.

1. At the drive keypad, press the **Hand/Auto** button

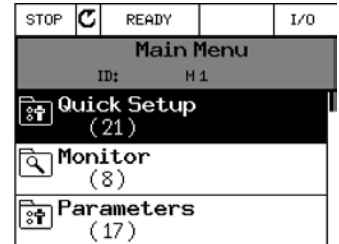

2. Use the **Up** and/or **Down Arrow** buttons to highlight **Drive**, then press **OK** .

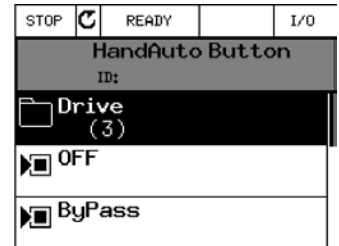

3. Use the **Up** and/or **Down Arrow** buttons to highlight **Hand**, then press **OK** .

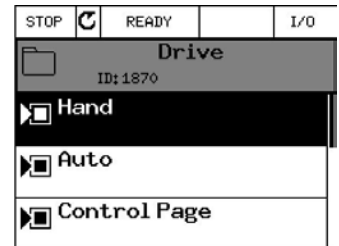

4. Use the **Up** and/or **Down Arrow** buttons to highlight **Activate**, then press **OK** .

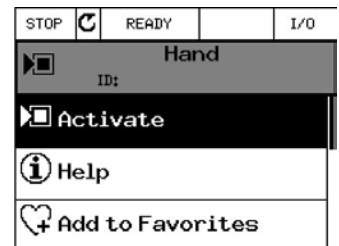

The unit is now operating in Hand mode. The following table outlines the buttons you can use to control the drive.

Button Icon	Button Name	Description
	Start	Start the Drive.
	Stop	Stop the Drive.
	Up and Down Arrows	Set the desired frequency (changes are immediate).

Button Icon	Button Name	Description
	OK	Once the frequency is set to the desired value, press OK to lock the setting.

OFF Mode

OFF mode overrides the automation system and does not allow the motor to run. For example, if you want to change filters in an air handling unit and want to turn the unit off for entry into the system.

In OFF mode, both the Bypass (M1) and the Output (M2) contactors are open to prevent power from getting to the motor.

- At the drive keypad, press the **Hand/Auto** button

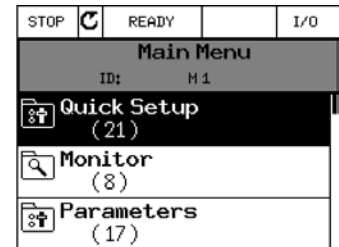

- Use the **Up** and/or **Down Arrow** buttons 

to highlight **OFF**, then press **OK**  ..

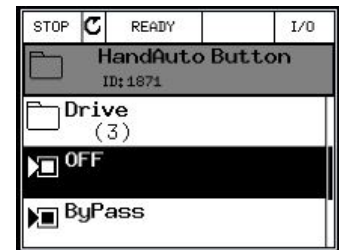

- Use the **Up** and/or **Down Arrow** buttons 

to highlight **Activate**, then press **OK** .



The unit is now off. It is not being controlled by the Drive or the Bypass. The motor will not spin, and the display will return to the default display.

Bypass Mode

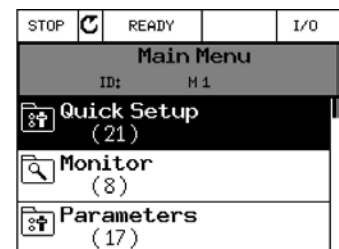

Bypass mode is used to override the automation system, and have the motor run directly from the voltage at full speed.

- At the drive keypad, press the **Hand/Auto** button

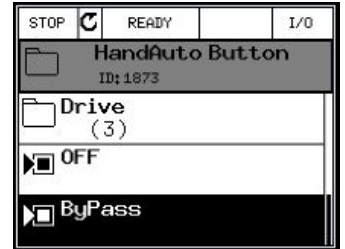

2. Use the **Up** and/or **Down Arrow** buttons  
to highlight **Bypass**, then press **OK** .



3. Use the **Up** and/or **Down Arrow** buttons  
to highlight **Activate**, then press **OK** .

The unit is now operating in the Bypass mode. Line supply power is directly supplied to the motor. No speed control is available in this mode. The display returns to the default display.

Diagnostic Board

Diagnostic Board

The diagnostic board provides a centralized location for diagnostics troubleshooting. The test points on this board make it easier to troubleshoot the bypass components. On the BT300 Demonstration Panel, the bypass override jumper and override safety jumpers have been wired to an SPST toggle switch for convenience. These are mounted to the left of the diagnostics board.

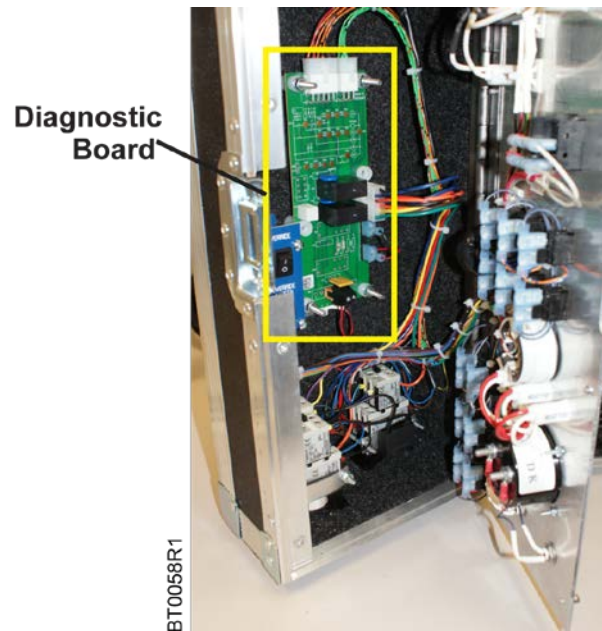

Figure 16: Diagnostic Board.

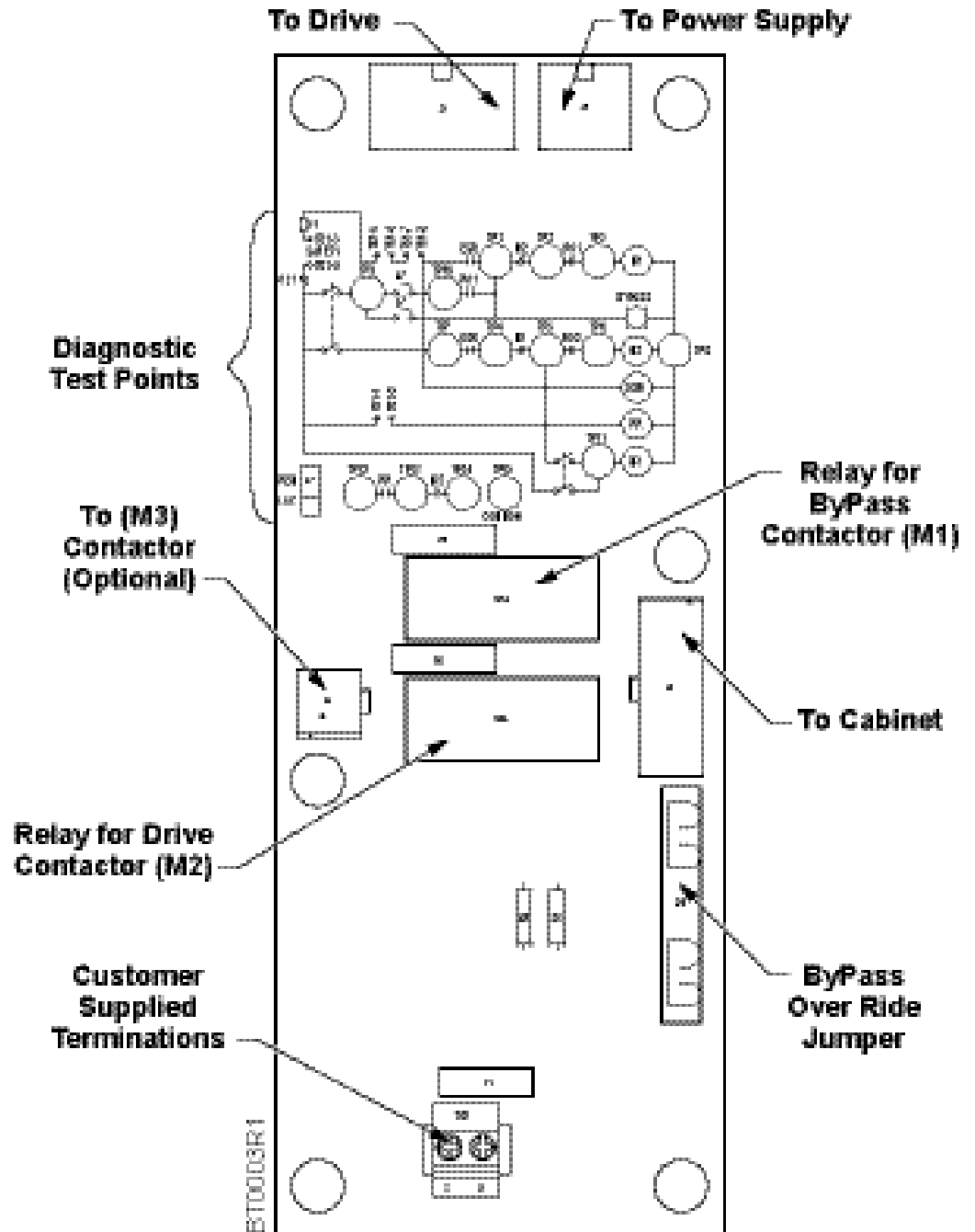

Figure 17: Electronic Bypass Diagnostic Board.

Test Points

The diagnostic test points on this board make it easier to troubleshoot the Bypass components. This same board is used in both the Conventional Bypass and the Electronic Bypass. Some test points are not relevant in the Electronic Bypass variant; however, the test points are still present.

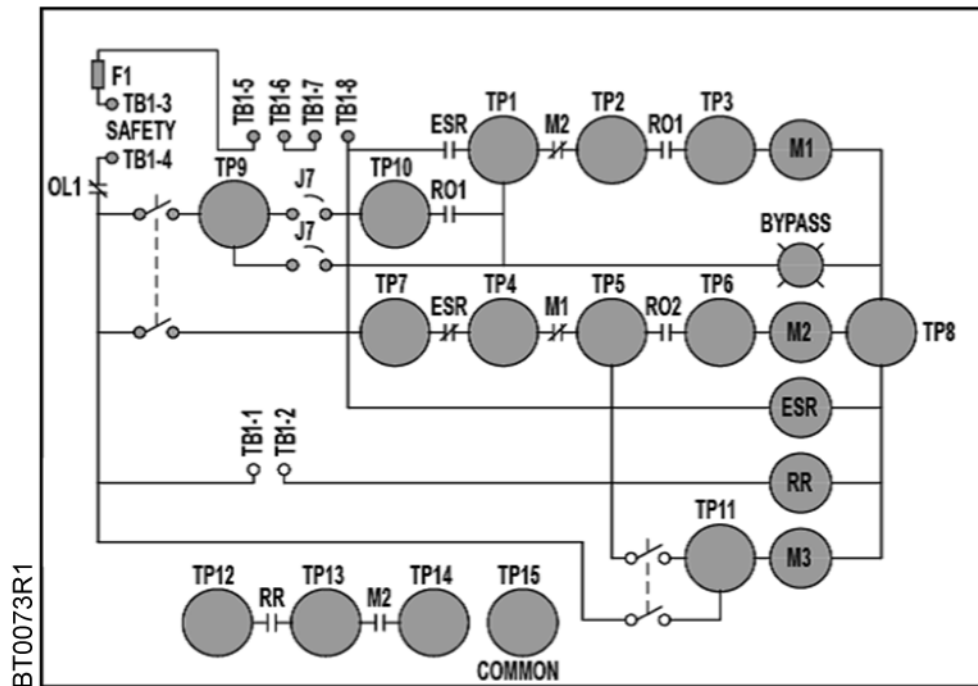

Figure 18: Diagnostic Test Points.

Test Point	Reference	Expected Voltage			Description
		Drive	Off	Bypass/ Essential Services	
TP1	TP8	115 Vac	115 Vac	115 Vac	Point between OL1 Terminal 96 and M2A-B Terminal 3.
TP2		0 Vac	115 Vac	115 Vac	Point between M2A-B Terminal 2 and Drive OPT-B5 card Terminal 22.
TP3		0 Vac	0 Vac	115 Vac	Drive OPT-B5 card Terminal 23 (M1 coil power).
TP4		115 Vac	115 Vac	115 Vac	Point between OL1 Terminal 96 and M1A-B Terminal 3.
TP5		115 Vac	115 Vac	0 Vac	Point between M1A-B terminal M2 and Drive OPT B5 card Terminal 25.
TP6		115 Vac	0 Vac	0 Vac	Drive OPT-B5 card Terminal 26 (M2 coil power).
TP7		N/A	N/A	N/A	Not used.
TP8		0 Vac	0 Vac	0 Vac	Vac Neutral.

Electronics Override

The diagnostic board provides an electronics override jumper location. A jumper, external switch, or customer-supplied start/stop can be wired to this location. This will override all of the electronic control logic and run the motor in Bypass mode. If a safety is required, it must be wired to the terminal strip on the diagnostic board. In the demo unit, switches have been added for each of these. The board and these switches are located under the standard I/O faceplate.

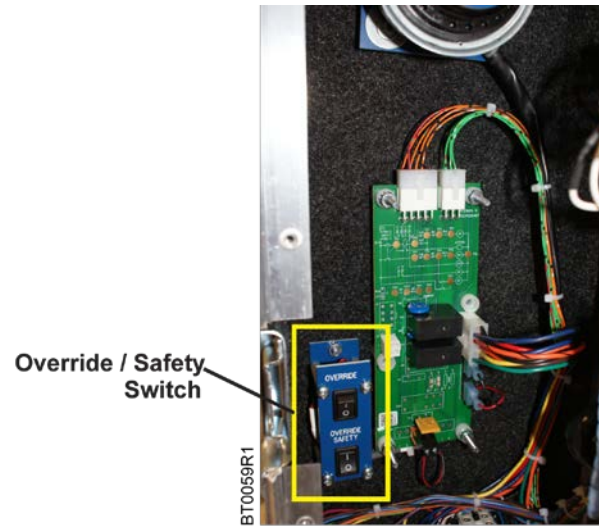

Figure 19: Override/Safety Switches.



Demonstration Steps

VFD Demo Mode

The following steps are used to demonstrate the BT300 VFD (without bypass option). Only the I/O located below the dotted line on the left hand side of the Demonstration Panel will be used (see Figure 7). With one exception, the service switch will still need to be turned on (located above the dotted line on the left side of the Demonstration Panel).

1. Turn on the Input Power switch (see Figure 5).
2. Turn on the Main Power switch (see Figure 6).
3. The Demonstration Panel must be in VFD Mode. Place the mode selection switch (see Figure 6) into the **VFD** (right side) setting.
4. Turn on the Service Switch (see Figure 7).
5. Turn off all Digital Inputs.
6. Rotate the Analog Inputs to the **0** position (counter-clockwise).
7. Return the unit to factory default settings to clear any previous programming. Using the keypad, navigate as follows: **Main Menu > User Settings (M6) > Parameter Backup (6.5) > Restore Factory Defaults (6.5.1) > Activate**

When the Siemens splash screen disappears, begin the demonstration.

1. Basic settings are prompted for as follows:
 - Language – Explain many languages are available, such as English, French, and Spanish.
 - Daylight Savings – Explain daylight savings for US, EU, and so on, can be selected. This is primarily used when the drive will be used to control Time of Day operations (start/stop to a time and day schedule). Most of the time this will really be handled by the BMS system.
 - Time – This is the standard HH:MM layout.
 - Year – This is the standard YYYY layout.
 - Date – **NOTE:** This the European standard of Day.Month
 - Startup Wizard – Verify that **Yes** is blinking (if not, use the **Up** and/or **Down Arrow** buttons  , and press **OK** .
2. Startup settings are prompted for as follows:
 - Fan or Pump – Explain that this will configure settings such as Accel/Decel Times, Flying Start, and so on.
 - The following motor nameplate data will be required:
 - Motor Nominal Voltage
 - Motor Nominal Frequency
 - Motor Nominal Speed
 - Motor Nominal Current

- Motor Cos PHI
 - Motor Nominal Power
 - Minimum Frequency – Minimum speed the motor must be driven to not overheat the motor.
 - Maximum Frequency – Maximum speed the motor can be driven to not overheat the motor.
 - I/O A Control Reference – Where does the speed reference come from?
 - Acceleration Time – How long to take to ramp from minimum to maximum speed.
 - Deceleration Time – How long to take to ramp from maximum to minimum speed.
 - Control Place Auto – Where does the start/stop come from?
 - Automatic Reset – Do you want the unit to automatically reset after a fault occurs?
 - Start Function – Flying start is used with fans due to high inertial loads and Ramping is used with pumps.
 - Bypass Wizard - when prompted, select No and press the button.
3. Display the multi-monitor, navigate to the following: **Main Menu > Multi-Monitor (M2) >**
 4. Use DI1 to issue a Start Forward command (**ON** is Start, **OFF** is Stop).







If a fan application is selected, the fan will start fast, and then return to the potentiometer setting.

5. Use AI1 or AI2 to ramp the drive up and down.
6. Use DI3 to generate an External Trip (**ON** is Trip, **OFF** is OK).
The LED below the keypad will blink red.
7. Use DI6 to acknowledge the External Trip (ON is a Reset, must turn back off).



DI3 must be off to reset the External Trip.

In lieu of using DI6, the **Back/Reset** button can be pressed and held for 2 seconds to acknowledge the fault.

8. Rotate the Analog Inputs to the **0** position (counter-clockwise).
9. Turn off DI1.
10. Press the **Hand/Auto** button , navigate to **Hand** and **Activate**.
The Keypad Control page displays.
11. Use the **Up** and/or **Down** arrows   to change the speed reference.
12. Use the  button to start the drive, and the  button to stop the drive.
13. Stop the drive.



14. Press the **Hand/Auto** button , navigate to **Auto** and **Activate**.
 The drive is now in I/O control again.

Bypass Demo Mode

The following steps are used to demonstrate the BT300 VFD with Electronic Bypass Feature Enabled. All of the I/O (above or below the dotted line) can be used for this demonstration mode

1. Turn on the Input Power switch (see Figure 5).
2. Turn on the Main Power switch (see Figure 6).
3. The Demonstration Panel must be in Bypass Mode. Place the mode selection switch (see Figure 6) into the **Bypass** (left side) setting.
4. Turn on the Service Switch (see Figure 7).
5. Turn off all Digital Inputs.
6. Rotate the Analog Inputs to the **0** position (counter-clockwise).
7. Return the unit to factory default settings to clear any previous programming. Using the keypad, navigate as follows: **Main Menu > User Settings (M6) > Parameter Backup (6.2) > Restore Factory Defaults (6.2.1) > Activate**

When the Siemens splash screen disappears, begin the demonstration.

1. Basic settings are prompted for as follows:
 - Language – Explain many languages are available, such as English, French, and Spanish.
 - Daylight Savings – Explain daylight savings for US, EU, and so on, can be selected. This is primarily used when the drive will be used to control Time of Day operations (start/stop to a time and day schedule). Most of the time this will really be handled by the BMS system.
 - Time – This is the standard HH:MM layout.
 - Year – This is the standard YYYY layout.
 - Date – **NOTE:** This is the European standard of Day.Month.
 - Startup Wizard – Verify that **Yes** is blinking (if not, use the **Up** and/or **Down** arrows  ) , and press **OK**  .
2. Startup settings are prompted for as follows:
 - Fan or Pump – Explain that this will configure settings such as Accel/Decel Times, Flying Start, and so on.
 - The following motor nameplate data will be required:
 - Motor Nominal Voltage
 - Motor Nominal Frequency
 - Motor Nominal Speed
 - Motor Nominal Current
 - Motor Cos PHI
 - Motor Nominal Power

- Minimum Frequency – Minimum speed the motor must be driven to not overheat the motor.
 - Maximum Frequency – Maximum speed the motor can be driven to not overheat the motor.
 - I/O A Control Reference – Where does the speed reference come from?
 - Acceleration Time – How long to take to ramp from minimum to maximum speed.
 - Deceleration Time – How long to take to ramp from maximum to minimum speed.
 - Control Place Auto – Where does the start/stop come from?
 - Automatic Reset – Do you want the unit to automatically reset after a fault occurs?
 - Start Function – Flying start is used with fans due to high inertial loads and Ramping is used with pumps.
 - Bypass Wizard - when prompted, select **Yes** and press **OK** .
3. Follow the Bypass Wizard, enabling the Electronic Bypass. Then, accept all defaults from that point on.





When **Electronic** is selected, the unit will go into fault Turn on DI2 and DI3, then press and hold the **Back/Reset** button for 2 seconds to clear the fault.

4. Display the multi-monitor, and navigate to the following: **Main Menu > Multi-Monitor (M2) >**
5. Use DI1 to issue a Start Forward command (**ON** is Start, **Off** is Stop).



If a fan application is selected, the fan will start fast, and then return to potentiometer setting.

6. Use AI1 or AI2 to ramp the drive up and down.
7. Rotate the Analog Inputs to the **0** position (counter-clockwise).
8. Turn off DI1.
9. Press the **Hand/Auto** button  and navigate to **Bypass > Activate**.
The motor will spin at full speed.
10. Press the **Hand/Auto** button  and navigate to **Off > Activate**.
The motor will coast to a stop.
11. Press the **Hand/Auto** button  and navigate to **Drive > Auto > Activate**.
12. Use DI1 to issue a Start Forward command (ON is Start, Off is Stop).



If a fan application is selected, the fan will start fast, and then return to the potentiometer setting.

13. Use AI1 or AI2 to ramp the drive up and down.
14. With the drive running, turn off the Service Switch (see Figure 7).
An undervoltage fault will occur.



This simulates a failure of the Power Module of the drive.
The keypad is still active.

15. The unit can be placed into Bypass mode by duplicating Step 9..
16. With the demo not running in Bypass, open the door on the left side of the Demonstration Panel (see Figure 16).



⚠ CAUTION

High voltages (110 Vac) exist on some wiring behind this door.

Connections have insulators installed for User safety; however, care should be taken any time the door is open.

17. Turn on the Electronics Override switch (see Figure 18).
The motor will spin full speed, just as if in Bypass mode.
18. Turn off the Electronics Override switch.
19. Close the I/O door.
20. Turn off the Service Switch.

Training Exercises



For Exercises 1 through 3, the Demonstration Panel should be placed in the VFD position. For all remaining exercises, the mode switch should be in the Bypass position.

Exercise 1

This exercise requires the BT300 Demonstration Panel to be factory reset and recommissioned. The standard keypad should be used to complete these steps. The Start-up Wizard will be used for ease of programming. Basic motor settings are required to be entered for this exercise. Shortened acceleration and deceleration times will be used to speed up the response time of the unit.

Startup Scenario:

The unit is controlling a fan on a rooftop unit in Las Vegas. This is a stand-alone drive (no bypass option is installed). A building management system is not available. The Users will start/stop the drive and set the speed reference manually.

Key information:

Supply voltage is 230 Vac

Motor nameplate data

- $V_n = 230 \text{ Vac}$
- $I_n = 0.4 \text{ A}$
- $F_n = 60 \text{ Hz}$
- $\text{Cos } \phi / \text{PF} = 0.7$
- $N_n = 1770 \text{ rpm}$

Ramp Times

- $\text{Accel} = 6 \text{ s}$
- $\text{Decel} = 3 \text{ s}$

Start/Stop Types

- Flying Start
- Coast to Stop

Auto Reset

- Undervoltage Fault
- Wait 2s
- Try 5 times in 80s timeline

Use the keypad to control the Start/Stop and Speed Reference of the Drive. Use the multi-monitor page to view the values during test run. Once complete, save the settings to the keypad.

Exercise 2

Exercise 1 settings must be in place for this exercise to properly work. The NET tool should be used to complete these steps. Control will be changed from keypad to I/O control. The motor is mounted in cool area and pre-heat of the motor windings is required for proper operation.

Startup Scenario:

A building management system will now be connected to the unit in the previous exercise. The BMS will provide a digital signal for start/stop forward, a digital signal for start/stop in reverse, digital signal for pre-heat mode, and a 0 to 10 Vdc signal for speed reference. The damper and end-switch will be wired directly to the drive for interlock control.

Key information:

Start/Stop

- Use 2 digital inputs: Forward, Reverse
- Both with rising edge

Motor Preheat Function

- Activated via Digital Input 4
- Use 0.2A current

Speed Reference

- AI1
- 2 to 10V

Magnetize Motor

- On Start for 3s
- 0.37A DC current

Enable Fan Interlock Function

- Damper activation on Relay Output 3
- End switch feedback on Digital Input 6
- Run Interlock, NOT Interlock for multi-pump

When testing the Interlock function, the Start/Stop will be enabled. Relay output will energize. A manual contact closure on digital input will be required since the physical devices are not present.



When preheat is On, the motor will not spin.

Exercise 3

This exercise requires the BT300 Demonstration Panel to be factory-reset and recommissioned. The standard keypad should be used during this exercise. The system will be using the drives internal PID controller.

Startup Scenario:

The unit will be controlling a fan on an air handling unit. This is a stand-alone drive (no bypass is installed). A BMS will provide a digital signal for start/stop. A preset flow setpoint will be entered via the keypad. A flow sensor will be wired to the drive as feedback for the drive's PID loop.

Key information:

Air Sensor

- Connected to AI2
- 4 to 20 mA
- 10 to 150 l/s

Operation

- Airflow setpoint is 45 l/s
- Standby once under 9hz for 30 seconds
- Wake level under 35 l/s

Exercise 4

This exercise requires the BT300 Demonstration Panel to be factory- reset and recommissioned. The standard keypad should be used during this exercise.

Startup Scenario:

The unit will be controlling a fan on an air handling unit. This is an electronic bypass unit. A BMS will provide a digital signal for start/stop and a 4 to 20 mA signal for speed reference. A low temperature detector and smoke sensor will be wired as safeties to the drive.

Key information:

Start/Stop

- Digital Input

Safeties

- Low Temp Detector
- Smoke Sensor

Speed Reference

- 4 to 20 mA

Electronic Bypass

View Operation

- Auto (via I/O control)
- Hand (user intervention)
- Off
- Bypass

Exercise 5

This exercise builds off of Exercise 4. Additional features of the Electronic Bypass will be used. The standard keypad should be used during this exercise.

Startup Scenario:

The customer has decided to change the sequence, the damper and end-switch will be wired directly to the drive, so that the interlock application can be used on the electronic bypass. An additional safety will be wired to the drive.

Key information:

Damper Control

- Relay Output

End Switch Feedback

- Digital Input

Start/Stop

- Digital Input

Safeties

- Low Temp Detector
- Smoke Sensor
- Vibration Sensor

Speed Reference

- 4 to 20 mA

Electronic Bypass

View Operation

- Auto (via I/O control)
- Bypass

Exercise 6

This exercise requires the BT300 Demonstration Panel to be factory-reset and recommissioned. Additional features of the Electronic Bypass will be used. The standard keypad should be used during this exercise.

Startup Scenario:

The unit is controlling a pump on a cooling tower. This is an electronic bypass installation. A BMS will provide a digital signal for start/stop reference, a digital signal for essential services, and a 0 to 10 Vdc signal for speed reference. Two safeties will be wired to the drive.

Key information:

Essential Services:

- Digital Input

Start/Stop

- Digital Input

Safeties

- Low Temp Detector
- Smoke Sensor
- Vibration Sensor

Speed Reference

- 0 to 10 Vdc

Electronic Bypass

View Operation

- Auto (via I/O control)
- Bypass

Other Functions to Test

There are many other functions that can be tested. Feel free to work with any of the functions that may interest you.

Functions:

Auto Reset

- External Fault
- Use 2-second delay
- Try 5 times in 50 seconds

Bypass

- Essential Services

DC Brake

- Set 1.5A for 5 seconds when stopping.

Energy Optimization

- Monitor
 - Motor Current
 - Motor Speed
 - Motor Torque
 - Motor Voltage
- At 25 Hz speed, turn the function on and off to examine the values of these changing. View the cause and effects.

Fire Mode

Preset Speed

- Preset 1 from Digital Input 4

Prohibited Frequencies

- Slow acceleration
- View the output speed reactions around the prohibited frequency.

Stopping Types

- Ramp vs. Coasting
- View the effects

Switching Frequency

- Min
- Max
- Observe the noise differences

Timer Functions

- See *3.11 Timer Functions*
- Program the example.

Exercise Answers/Information

Key information that pertains to the setup of the exercises will be found in this section. Associated parameters and I/O used will be defined to aid in finding the recommended solution.

Exercise 1

Key information:

Unit is located in Las Vegas

- The Time (2201) setting after factory reset should be set to MST.
- Navigate to I/O and then **Hardware > Real Time Clock > Time (5.5.2)** to verify the time setting.

Motor nameplate data

- $V_n = 230 \text{ Vac}$
 - Set **Motor Nom Voltg (3.1.1.1)** to **230**
- $I_n = 0.4\text{A}$
 - Set **Motor Nom Currnt (3.1.1.4)** to **0.4**
- $F_n = 60\text{Hz}$
 - Set **Motor Nom Freq (3.1.1.2)** to **60**
- $\text{Cos } \phi/\text{PF} = 0.7$
 - Set **Motor Cos Phi (3.1.1.5)** to **0.7**
- $N_n = 1770 \text{ rpm}$
 - Set **Motor Nom Speed (3.1.1.3)** to **1770**
- $\text{HP} = 1$
 - Set **Motor Nom Speed (3.1.1.3)** to **1770**

Ramp Times

- Accel = 6s
 - Set **Accel Time 1 (3.4.2)** to 6
- Decel = 3s
 - Set **Decel Time 1 (3.4.3)** to 3

Start/Stop Types

- Flying Start
 - Set **Start Function (3.2.4)** to **Flying Start**





NOTE: *This is configured using the Startup Wizard.*

- Coast to Stop
 - Set **Stop Function (3.2.5)** to **Coasting**

NOTE: *This is configured using the Startup Wizard.*

Auto Reset

- Enable
 - Set **Automatic Reset (3.10.1)** to **Enabled**
- Undervoltage Fault
 - Set **Undervoltage Flt (3.10.6)** to **Yes**
- Wait 2s
 - Set **Wait Time (3.10.3)** to 2
- Try 5 times in 80s timeline
 - Set **Trial Time (3.10.4)** to 80
 - Set **Number of Trials (3.10.5)** to 5

- To use keypad for control, press the **Hand/Auto** button . Highlight **Hand** and press **OK** . Highlight **Activate** and press **OK** . Speed reference controlled in the upper selection. Start/stop is controlled via the  /  buttons.

Exercise 2

Key information:

Start/Stop

- 2 digital inputs are the default settings of the Drive:
 - Forward = Digital Input 1 by default
Set **Ctrl Signal 1A (3.5.1.1)** to **DigINSlotA.1**
 - Reverse = Digital Input 2 by default
Set **Ctrl Signal 2A (3.5.1.2)** to **DigINSlotA.2**

NOTE: *These are configured using the Startup Wizard.*

Motor Preheat Function

- Activated via digital input 4
 - Set **Preheat Function (3.1.2.5)** to **DIN Control**
 - Set **Preheat ON (3.5.1.14)** to **DIGINSlotA.4**

- Use 0.2A current
 - Set **Preheat Current (3.1.2.7)** TO **0.2**

Speed Reference

- Use AI1
 - Set **I/O A Ctrl Ref (3.3.3)** to **AI1**

NOTE: *This is configured using the Startup Wizard.*

- 2 to 10V Signal
 - Set **AI1 Signal Range (3.5.2.3)** to **2-10V/4-20mA**

NOTE: *This is configured using the Startup Wizard.*

Magnetize Motor

- On Start for 3s
 - Set **StarMagnTime (3.4.7)** to **3**
- 0.3A DC current
 - Set **MagnCurrent (3.4.8)** to **.37**

Enable Fan Interlock Function

- Enable Interlock
 - Set **InterlockStart (3.2.9)** to **Enabled**.
- Damper activation on Relay Output 3
 - Set **RO3 Function (3.5.3.2.7)** to **DamperLogicCtrl**
- End switch feedback on Digital Input 6
 - Set **Run Interlock 1 (3.5.1.12)** to **DIGINSlotA.6**

Exercise 3

Key information:

NOTE: *Use the PID-Mini Wizard to complete the setup for the Air Sensor and the PID settings.*

NOTE: *There are several parameters that are changed via the PID-Mini Wizard. The following are just a few of the parameters that are addressed during the configuration.*

Air Sensor

- Connected to AI2
 - Set **IO A Ctrl Ref (3.3.3)** to **A12**

NOTE: *This is configured using the PID-Mini Wizard.*

- 4 to 20mA
 - Set **AI1 Signal Range (3.5.2.3)** to **2-10V/4-20mA**

NOTE: *This is configured using the PID-Mini Wizard.*

- 10 to 150 l/s
 - Set **ProcessUnitSel. (3.12.1.4)** to **l/s**
 - Set **ProcessUnitMin (3.12.1.5)** to **10**
 - Set **ProcessUnitMax (3.12.1.6)** to **150**

NOTE: *These are configured using the PID-Mini Wizard.*

Operation

- Airflow setpoint is 45 l/s
 - Set **SP1 Source (3.12.2.4)** to **Keypad SP1**
 - Set **Keypad SP1 (3.12.2.1)** to **45**

NOTE: *These are configured using the PID-Mini Wizard.*

- Standby once under 9hz for 30 seconds
 - Set **SP1 Sleep Freq (3.12.2.7)** to **9**
 - Set **SP1 Sleep Delay (3.12.2.8)** to **30**

NOTE: *These are configured using the PID-Mini Wizard.*

- Wake level under 35 l/s
 - Set **SP1 WakeUpLevel (3.12.2.9)** to **35**

NOTE: *This is configured using the PID-Mini Wizard.*

Exercise 4

Key information:

NOTE: *Use the Bypass Wizard to complete the setup for the Electronic Bypass.*

Start/Stop

- Use Digital Input 1
 - Set **Ctrl Signal 1A (3.5.1.1)** to **DigINSLotA.1**

NOTE: *This is configured using the Startup Wizard.*

Safeties

- Low Temp Detector - Use Digital Input 2
 - Set **Remote Safety 1 (3.5.1.44)** to **DigINSlotA.2**

NOTE: *This is configured using the Bypass Wizard.*

- Smoke Sensor - Use Digital Input 3
 - Set **Remote Safety 2 (3.5.1.45)** to **DigINSlotA.3**

NOTE: *This is configured using the Bypass Wizard.*

Speed Reference

- 4 to 20mA on Ai2
 - Set **I/O A Ctrl Ref (3.3.3)** to **AI2**
 - Set **AI2 Signal Range (3.5.2.9)** to **2-10V/4-20mA**

NOTE: *These are configured using the Startup Wizard.*

Electronic Bypass

- Set **ByPass (3.17.4)** to **Electronic**

NOTE: *This is configured using the Startup Wizard.*

Exercise 5

Key information:

NOTE: *Use the Bypass Wizard to complete the setup for the Interlock application.*

Damper Control

- Relay Output
 - Set **RO3 Function (3.5.3.2.7)** to **DamperLogicCtrl**

NOTE: *This is configured using the Bypass Wizard.*

End Switch Feedback

- Digital Input
 - Set **Run Enable (3.5.1.11)** to **DigINSlotA.4**

NOTE: *This is configured using the Bypass Wizard.*

Safeties

- Low Temp Detector
 - Set **Remote Safety 1 (3.5.1.44)** to **DigINSlotA.2**

NOTE: *This is configured using the Bypass Wizard.*

- Smoke Sensor
 - Set **Remote Safety 2 (3.5.1.45)** to **DigINSlotA.3**

NOTE: *This is configured using the Bypass Wizard.*

- Vibration Sensor
 - Set **Remote Safety 3 (3.5.1.46)** to **DigINSlotD.1**

Exercise 6

Key information:

NOTE: *When the Bypass Wizard is run again, all I/O is reset to the defaults; so, if safeties were programmed to different Digital Inputs or disabled completely, they will be re-enabled as default settings.*

Essential Services:

- Digital Input
 - Set **Essential Services (3.5.1.52)** to **DigINSlotA.6**

NOTE: *This is configured using the Bypass Wizard.*

Start/Stop

- Digital Input
 - Set **Ctrl Signal 1A (3.5.1.1)** to **DigINSlotA.1**

NOTE: *This is configured using the Startup Wizard.*

Safeties

- Low Temp Detector
 - Set **Remote Safety 1 (3.5.1.44)** to **DigINSlotA.2**

NOTE: *This is configured using the Bypass Wizard.*

- Vibration Sensor
 - Set **Remote Safety 2 (3.5.1.45)** to **DigINSlotA.3**

NOTE: *This is configured using the Bypass Wizard.*

Speed Reference

- 0 to 10 Vdc

- Set I/O A Ctrl Ref (3.3.3) to AI1
- Set AI1 Signal Range (3.5.2.3) to 0-10V/0-20mA

NOTE: *This is configured using the Bypass Wizard.*

Issued by
Siemens Industry, Inc.
Building Technologies Division
1000 Deerfield Pkwy
Buffalo Grove IL 60089
Tel. +1 847-215-1000

© 2014 Copyright Siemens Industry, Inc.
Technical specifications and availability subject to change without notice.