

## Ball valve actuators

SQL..A00T..



### **Ball valve actuator, for use in on-off/3-position and modulating.**

- Nominal torque 20 Nm, 35 Nm, 50 Nm
- SQL33..A00T..., operating voltage AC 230 V ~; SQL336A00T.. with auxiliary switch signal feedback
- SQL13..A00T..., operating voltage AC 24 V ~ / DC 24 V = ; SQL136A00T.. with auxiliary switch signal feedback
- SQL161A00T..., operating voltage AC 24 V ~ / DC 24 V =
- Mechanical adjustable range 0...90°
- With connection terminals, fit various on-site cables
- Manually adjust wrench and pointer stroke indication
- Flexible adaptive function
- The actuator is directly connected to the valve, no additional accessories are required for easy installation

## Use

Combined with VAF41..series valve in HVAC systems for on-off and modulating control.

## Type summary

Product type	Stock No.	Open-loop control	Operating voltage	Positioning signal input Y	Position indicator	Self-adapting rotation angle ranges	Rotation direction switch	90° running time/s		
SQL331A00T20	S55164-A160	On-off/3-position	AC 230 V ~	-	-	-	-	30 s		
SQL331A00T35	S55164-A161									
SQL331A00T50	S55164-A162									
SQL336A00T20	S55164-A170								AC 24 V ~ DC 24 V =	-
SQL336A00T35	S55164-A171									
SQL336A00T50	S55164-A172									
SQL131A00T20	S55164-A163		Dual auxiliary switch							
SQL131A00T35	S55164-A164									
SQL131A00T50	S55164-A165									
SQL136A00T20	S55164-A173				Dual auxiliary switch					
SQL136A00T35	S55164-A174									
SQL136A00T50	S55164-A175									
SQL161A00T20	S55164-A166	Modulating	DC 0/2...10 V 4/0...20 mA	U = DC 0/2...10 V 4/0...20 mA	√	√				
SQL161A00T35	S55164-A167									
SQL161A00T50	S55164-A168									

## Equipment combinations

Actuator	SQL331A00T20 SQL131A00T20 SQL336A00T20 SQL136A00T20 SQL161A00T20		SQL331A00T35 SQL131A00T35 SQL336A00T35 SQL136A00T35 SQL161A00T35		SQL331A00T50 SQL131A00T50 SQL336A00T50 SQL136A00T50 SQL161A00T50	
	$\Delta p_{max}$	$\Delta p_s$	$\Delta p_{max}$	$\Delta p_s$	$\Delta p_{max}$	$\Delta p_s$
Ball valve	[kPa]					
VAF41.65-63/2	400	400	-	-	-	-
VAF41.80-100/2	400	400	-	-	-	-
VAF41.100-160/2	-	-	400	400	-	-
VAF41.125-250/2	-	-	400	400	-	-
VAF41.150-360/2	-	-	-	-	400	400

### Note:

$\Delta p_{max}$  = Maximum permissible differential pressure across valve's control path, valid for the entire actuating range of the motorized valve.

For low noise operation we recommend a maximum permissible differential pressure of 240 kPa.

$\Delta p_s$  = Maximum permissible differential pressure at which the motorized valve will close securely against the pressure (close off pressure).

## Product documentation

Topic	Title	Document ID
Mounting Instructions	Ball valve	A6V11162533
Mounting Instructions	Actuator	A6V13894210
CE	Ball valve	A5W00307632A
RCM	Ball valve	A5W00307634A
EPD	Ball valve	A5W00291831A

Related documents such as the environmental declarations, declarations of conformity, etc., can be downloaded from the following Internet address:

[www.siemens.com/bt/download](http://www.siemens.com/bt/download)

## Technical design

### LED operating status indication

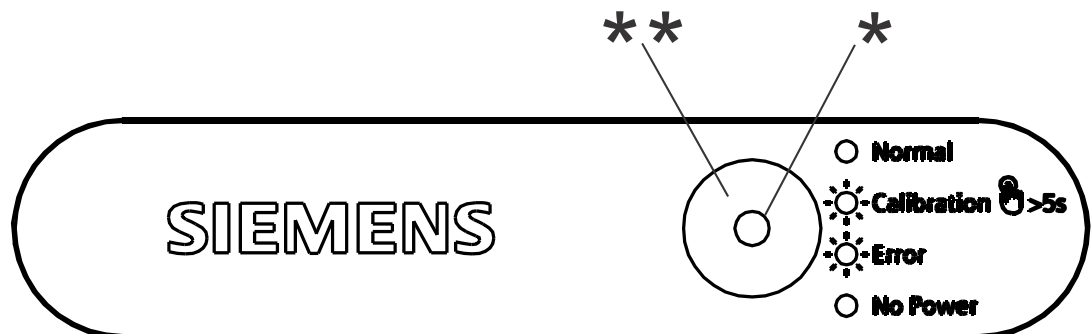

Function/Status	LED light	Instructions, troubleshooting
Normal operation mode	Green ON	Normal operation
Self-adaption mode	Yellow flashing	The light stops flashing after 2 minutes, and the self-adaption is over.
Warning	Red flashing	Fail warning <sup>1)</sup>
Actuator OFF	OFF	-

<sup>1)</sup> Troubleshooting with self-adaption mode, and Power ON/OFF.

\* LED light

\*\* Manual button

## Commissioning

Factory setting	
Manual adaption mode.	
Commissioning	
<ol style="list-style-type: none"> <li>1. Turn ON the power switch.</li> <li>2. Press and hold the round button for 5 seconds. The actuator LED is flashing yellow, and the actuator will switch into self-adaption mode: Firstly run to the "0" direction limit position, and then run to the "1" direction limit position. After yellow LED light flashes in 2 minutes, the self-adaption completes; and adaptation of the actuator with valve is completed.</li> </ol>	If the LED flashes red, it indicates that the self-adaption has detected an error.
Normal operation	
The actuator operates to a position controlled by the control signal Y.	

## DIP switches

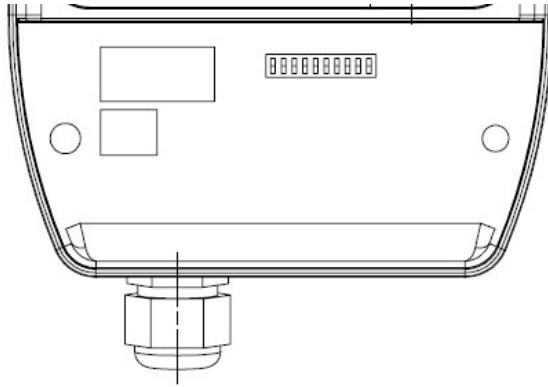

No.	Function	Setting	Function description	Factory setting
S1-1	Control/feedback signal	On	4~20 mA or DC 2~10 V	Off
		Off	0~20 mA or DC 0~10 V	
S1-2	Control signal type	On	Current type	Off
		Off	Voltage type	
S1-3	Input impedance matching	On	Voltage type	On
		Off	Current type	
S1-4	Feedback signal type	On	Current type	Off
		Off	Voltage type	
S1-5	Operation mode	On	The actuator runs in the "1" direction when the control signal increases, and runs in the "0" direction when the control signal decreases.	On
		Off	The actuator runs in the "0" direction when the control signal increases, and runs in the "1" direction when the control signal decreases.	
S1-6	Signal fail mode	On	When the control signal type is set to "voltage type" or "current type," the internals of the actuator automatically provides the minimum control signal.	On
		Off	1) When the control signal type is set to "voltage type," the internals of the actuator automatically provides the maximum control signal. 2) When the control signal type is set to "current type," the internals of the actuator automatically provides the minimum control signal.	
S1-7	Self-adaption mode	On	The actuator is in power ON self-adaption mode.	Off
		Off	The actuator is in manual adaption mode.	
S1-8	-	N/A	-	-
S1-9	-	-	-	-
S1-10	Signal fail position in place	On	When the control signal is disconnected, the actuator remains at the current signal position (only for input signal 4~20 mA).	Off
		Off	The actuator sets up operation according to S1-6.	

**Note:**

SQL161A00T.. modulating

The control feedback signal factory setting is: 0-10 V

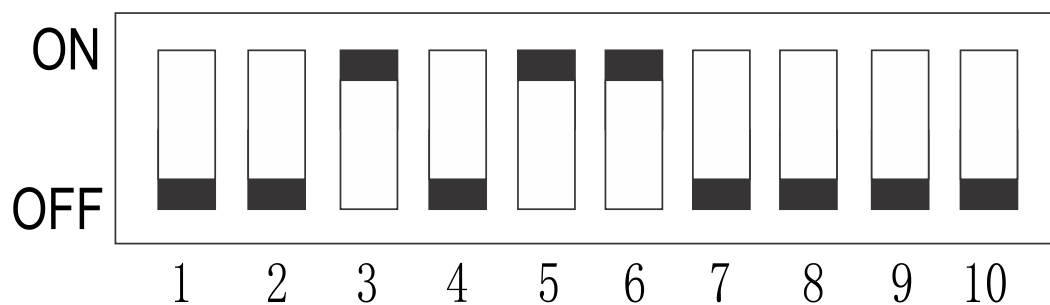

When the control feedback signal is 4-20 mA, the DIP setting is:

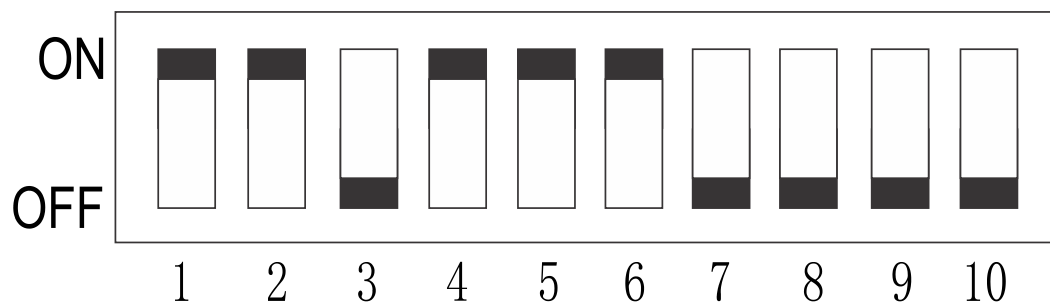

SQL131A00T../SQL331A00T../SQL136A00T../SQL336A00T..DIP switch not applicable

**Notes**

The following sections include important sales or engineering-related information. Some of the information has already been included herein. Unnecessary sections can be deleted.

**Security**

**⚠ CAUTION**



**National safety regulations**

Failure to comply with national safety regulations may result in personal injury and property damage

- Observe national provisions and comply with the appropriate safety regulations.

**Engineering**

For cable connections, see Wiring diagram [▶ 11].

## Mounting

See “Mounting instructions” A6V11162533 and A6V13894210.

Both ball valve and rotary actuator can easily be assembled at the mounting location. Neither special tools nor adjustments are required.

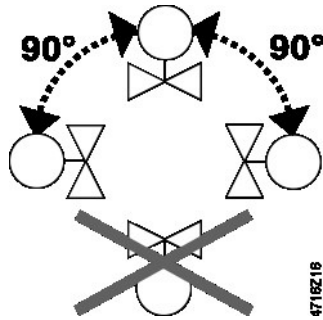

### Protection against weather, humidity and dirt



Protection against direct sunlight and rain

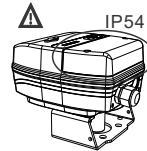

Protection only with closed cover!

## Mounting

### ⚠ WARNING



#### No internal line protection for supply lines to external consumers

Risk of fire and injury due to short-circuits

- Adapt the line diameters as per local regulations to the rated value of the installed fuse.

## Maintenance

The actuators are maintenance-free.

## Disposal



This symbol or any other national label indicate that the product, its packaging, and, where applicable, any batteries may not be disposed of as domestic waste. Delete all personal data and dispose of the item(s) at separate collection and recycling facilities in accordance with local and national legislation.

For additional details, refer to [Siemens information on disposal](#).

Power supply (SQL161A00T.., SQL13..A00T..)		
Operating voltage (SELV/PELV)		AC 24 V ~ - 15 % + 20 % (20.4...28.8 V ~) DC 24 V ≐ - 15 % + 20 % (20.4...28.8 V ≐)
Frequency		50/60 Hz
Power consumption – Operating	SQL161A00T20, SQL13..A00T20	AC 24 V: 30 VA / DC 24 V: 12 VA
	SQL161A00T35, SQL13..A00T35, SQL161A00T50, SQL13..A00T50	AC 24 V: 40 VA / DC 24 V: 20 VA

Power supply (SQL331A00T..)		
Operating voltage (SELV/PELV)		AC 230 V ~ ± 15 % (195.5...264.5 V ~)
Frequency		50/60 Hz
Power consumption – Operating	SQL33..A00T20	40 VA
	SQL33..A00T35	50 VA
	SQL33..A00T50	

Function data			
	SQL..A00T20	SQL..A00T35	SQL..A00T50
Nominal torque	20 Nm	35 Nm	50 Nm
Nominal rotation angle (with position indication)	90°		
Runtime at nominal rotation angle 90°	30 s		

Input		
Positioning signal for SQL13..A00T.. Operating voltage AC 24 V ~ / DC 24 V ≐	(wires G0-Y1) (wires G0-Y2)	Clockwise - The actuator runs to "0" direction, ball valve closing Counterclockwise - The actuator runs to "1" direction, ball valve opening
Positioning signal for SQL33..A00T.. Operating voltage AC 230 V ~	(wires N-Y1) (wires N-Y2)	Clockwise - The actuator runs to "0" direction, ball valve closing Counterclockwise - The actuator runs to "1" direction, ball valve opening
Positioning signal for SQL161A00T.. Input voltage Input current Voltage input resistance Current input resistance Protected against faulty wiring	(wires Y-G0) (wires Y-G0)	DC 0/2...10 V 4/0...20 mA >100 kΩ <200 Ω Max. AC 24 V ~/ DC 24...40 V ≐

Output		
Position indicator Output signal (SQL161A00T..) Output voltage Output current Voltage load impedance Current load impedance Protected against faulty wiring	(wires U-G0)	DC 0/2...10 V 4/0...20 mA >2 kΩ <500 Ω Max. AC 24 V ~ / DC 24...40 V =

Auxiliary switch (SQL336A00T.., SQL136A00T..)	
Switching voltage	AC 24...250 V ~ / DC 12...30 V =
Contact loading	2 A resistive 1 A inductive, min. 10 mA @ AC 1 A resistive, 0.5 A inductive, min. 10 mA @ DC

Connection terminals	
Water joint	PG13.5
Spare connection port	PG13.5

Safety class and protection level	
Protection class AC 24 V ~ / DC 24 V = AC230V ~	EN 60730 Class III Class I
Protection level of housing	IP 54, as per EN 60529 (see Product documentation [▶ 3])

Environmental conditions	
Operation Mounting position Temperature Humidity, non-condensing	Internal, weather-protected -15...+55 °C 5...95 % r.h.
Transportation Temperature Humidity, non-condensing	-25...+70 °C <95 % r.h.
Storage Temperature Humidity, non-condensing	-15...+55 °C 5...95 % r.h.

Standards, directives and certifications	
Product standards	EN 60730 Part 1 - General requirements for electromotive actuators Part 2-14 -Particular requirements for electric actuators
Electromagnetic compatibility (Applied)	For residential, commercial, and industrial environments
EU certification (CE)	A5W00307632A <sup>1)</sup>
RCM certification	A5W00307634A <sup>1)</sup>

Environmental compatibility
The product environmental declaration A5W00291831 <sup>1)</sup> contains data on environmentally compatible product design and assessments (RoHS compliance, materials composition, packaging, environmental benefit, disposal).

Dimensions	
Actuator W x H x D	See Dimensions (mm) [► 14].

Weight		
Excl. packaging	SQL..A00T20	2.38 kg
	SQL..A00T35	2.58 kg
	SQL..A00T50	2.88 kg

<sup>1)</sup> Documentation can be downloaded at: <http://siemens.com/bt/download>.

Internal diagram

SQL331A00T..	SQL131A00T..	SQL161A00T..
On-off/3-position, AC 230 V ~	On-off/3-position, AC 24 V ~ / DC 24 V =	Modulating, AC 24 V ~ / DC 24 V =
<p>AC 230 V ~</p> <p>N</p> <p>M</p> <p>Y1 Y2</p> <p>A6V13769562D02</p>	<p>AC 24 V ~ DC 24 V =</p> <p>G G0</p> <p>M</p> <p>Y1 Y2</p> <p>A6V13769562D01</p>	<p>AC 24 V ~ 0/2~10 V DC 24 V = 0/4~20 mA</p> <p>G Y</p> <p>M</p> <p>100% 0%</p> <p>G0 U</p> <p>A6V13769562D00</p>

SQL336A00T..	SQL136A00T..
On-off/3-position, AC 230 V ~, auxiliary signal feedback	On-off/3-position, AC 24 V~/DC 24 V=, auxiliary signal feedback
<p>AC 230 V ~</p> <p>N</p> <p>M</p> <p>Y1 Y2</p> <p>Q13 Q14 Q23 Q24</p> <p>A6V13894210D00</p>	<p>AC 24 V ~ DC 24 V =</p> <p>G G0</p> <p>M</p> <p>Y1 Y2</p> <p>Q13 Q14 Q23 Q24</p> <p>A6V13894210D01</p>

## External wiring diagram

SQL33..A00T..	SQL13..A00T..	SQL161A00T..
<b>3-position, AC 230 V ~</b>	<b>3-position, AC 24 V ~ / DC 24 V ≍</b>	<b>Modulating, DC 0(2)...10 V /4(0)...20 mA</b>
<p>AC 230 V ~</p> <p>Y1 Y2</p> <p>N</p> <p>AV13769562D07</p>	<p>AC 24 V ~ DC 24 V ≍</p> <p>G</p> <p>G0 Y1 Y2</p> <p>AV13769562D04</p>	<p>AC 24 V ~ DC 24 V ≍</p> <p>G</p> <p>Y U</p> <p>G0</p> <p>AV13769562D06</p>
<b>On-off, SPDT, AC 230 V ~</b>	<b>On-off, SPDT, AC 24 V ~/DC 24 V ≍</b>	
<p>AC 230 V ~</p> <p>Y1 Y2</p> <p>N</p> <p>AV13769562D05</p>	<p>AC 24 V ~ DC 24 V ≍</p> <p>G</p> <p>G0 Y1 Y2</p> <p>AV13769562D03</p>	

## Connection terminals

<b>SQL331A00T..</b>	
AC 230 V, on-off/3-position	
Y2	Positioning signal (Counterclockwise- The actuator runs to "1" direction, ball valve opening)
Y1	Positioning signal (Clockwise- The actuator runs to "0" direction, ball valve closing)
N	System neutral
<b>SQL336A00T..</b>	
AC 230 V, on-off/3-position	
Y2	Positioning signal (Counterclockwise- The actuator runs to "1" direction, ball valve opening)
Y1	Positioning signal (Clockwise- The actuator runs to "0" direction, ball valve closing)
N	System neutral
Q13	Auxiliary switch signal feedback contact, close position
Q14	Auxiliary switch signal feedback contact, close position, normal open
Q23	Auxiliary switch signal feedback contact, close position
Q24	Auxiliary switch signal feedback contact, close position, normal open
<b>SQL131A00T..</b>	
AC 24 V, DC 24 V, on-off/3-position	
G	System potential
G0	System neutral
Y1	Positioning signal (Clockwise- The actuator runs to "0" direction, ball valve closing)

Y2	Positioning signal (Counterclockwise- The actuator runs to "1" direction, ball valve opening)
<b>SQL136A00T..</b>	
AC 24 V, DC 24 V, on-off/3-position	
G	System potential
G0	System neutral
Y1	Positioning signal (Clockwise- The actuator runs to "0" direction, ball valve closing)
Y2	Positioning signal (Counterclockwise- The actuator runs to "1" direction, ball valve opening)
Q13	Auxiliary switch signal feedback contact, close position
Q14	Auxiliary switch signal feedback contact, close position, normal open
Q23	Auxiliary switch signal feedback contact, close position
Q24	Auxiliary switch signal feedback contact, close position, normal open
<b>SQL161A00T..</b>	
AC 24 V, DC 24 V, 0(2)...10 V/4(0)...20 mA	
G	System potential
G0	System neutral/Signal neutral
Y	Positioning signal 0(2)...10 V/4(0)...20 mA
U	Positioning indication 0(2)...10 V/4(0)...20 mA

**Dimensions (mm)**

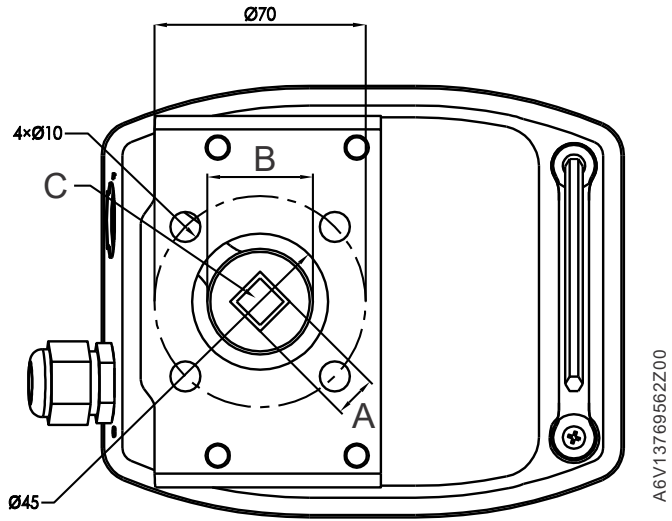

Type	A (mm)	B (mm)	Hole depth C (mm)	Weight (kg)
SQL..A00T20	11	24	20	2.3
SQL..A00T35	11	24		2.5
SQL..A00T50	14	35		2.8

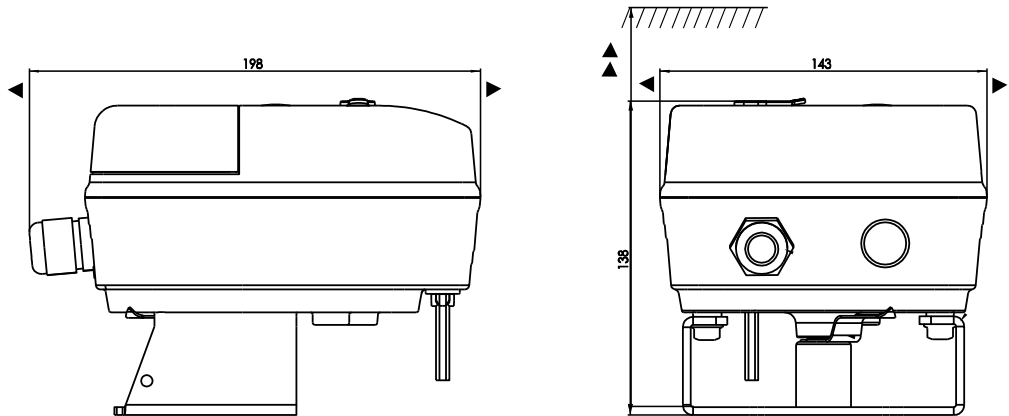

**Spatial scope, distance from wall**

▶	>100	Minimum gap from the ceiling or wall for mounting, connection, operation, and maintenance, etc.
▶▶	>200	

## Revision numbers

Product type	Valid from rev. no.
SQL331A00T20	..B
SQL331A00T35	..B
SQL331A00T50	..B
SQL131A00T20	..B
SQL131A00T35	..B
SQL131A00T50	..B
SQL161A00T20	..B
SQL161A00T35	..B
SQL161A00T50	..B
SQL336A00T20	..A
SQL336A00T35	..A
SQL336A00T50	..A
SQL136A00T20	..A
SQL136A00T35	..A
SQL136A00T50	..A

Issued by  
Beijing Siemens Cerberus Electronics Ltd.  
Smart Infrastructure

No.1, Fengzhi East Road, Xibeiwang  
Haidian District, 100094 BEIJING, China  
+86 10 64768806  
[www.siemens.com/buildingtechnologies](http://www.siemens.com/buildingtechnologies)

© Siemens 2022  
Technical specifications and availability subject to change without notice.

---

Document ID    A6V13769562\_en--\_b  
Edition        2024-05-31