

SIEMENS

BACnet ATEC Controller

VAV - with Electric Heat or Baseboard Radiation, Application 6632

Application Note

Table of Contents

Overview	5
BACnet	7
Hardware Inputs	8
Room Unit Identification	8
Hardware Outputs.....	8
Ordering Notes	8
Sequence of Operation	9
Control Temperature Setpoints	9
CTL STPT Using Standard/Absolute Mode (Digital Room Unit, Revision 26 and later).....	9
CTL STPT Using Warmer/Cooler Mode (Digital Room Unit, Revision 26 and later).....	10
CTL STPT Using Standard/Absolute Mode (Analog or Digital Room Unit)	10
CTL STPT Using Warmer/Cooler Mode (Analog Room Unit Only)	11
Heating/Cooling Switchover.....	11
Heating/Cooling Switchover using Standard/Absolute Mode (Digital Room Unit, Revision 26 and later).....	12
Heating/Cooling Switchover Using Warmer/Cooler Mode (Digital Room Unit, Revision 26 and later).....	12
Heating/Cooling Switchover Using Standard/Absolute Mode (Analog Room Unit)	13
Heating/Cooling Switchover Using Warmer/Cooler Mode (Analog Room Unit)	13
Room Temperature, Room Temperature Offset and CTL TEMP.....	14
Day and Night Modes	14
Night Mode Override Switch	14
Ventilation Demand Minimum.....	15
Night Flow Minimum	15
Control Loops	15
Staged Heating Coil - Terminal Unit	17
Staged Heating Coil - Baseboard Radiation.....	19
Sequencing Logic	19
Electric Heat Interlock.....	21
Calibration.....	22
Room Unit Operation	22
Sensor Select	22
Room CO2.....	23
Room RH.....	23
Room DEW POINT	23
Auto Discovery.....	23
Auto Addressing	24

PPCL STATUS	24
Fail Mode Operation	24
Performing the Automated Fault Detection and Diagnostics	24
Application Notes	27
Wiring Diagram	27
Application 6632 Point Database	29

Overview

In Application 6632, the controller modulates the supply air damper of the terminal box for cooling and controls stages of electric reheat or baseboard radiation for heating. When in heating, the terminal box either maintains minimum airflow or modulates the supply air damper. In order for the terminal box to work properly, the central air-handling unit must provide supply air.

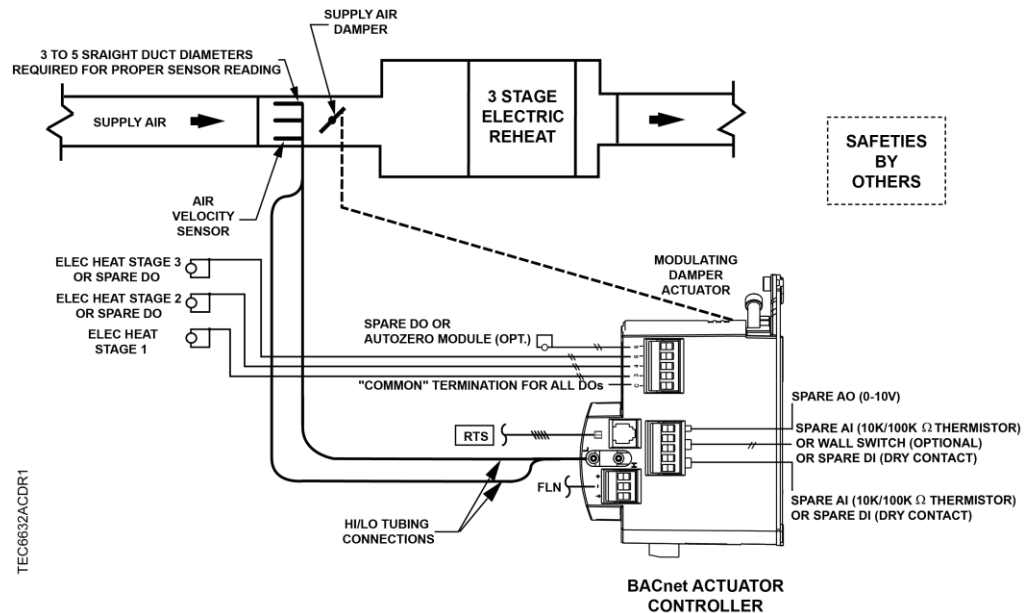

Application 6632 with Electric Heat Control Diagram.

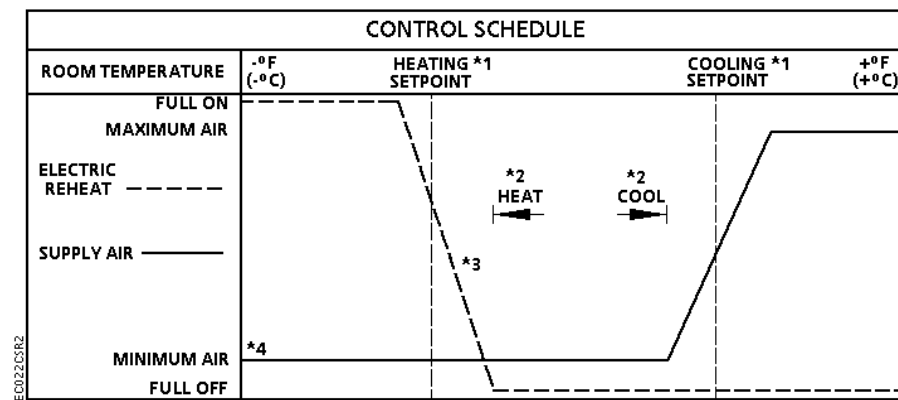

Application 6632 with Electric Heat Control Schedule.



NOTES:

1. See *Control Temperature Setpoints*.
2. See *Heating/Cooling Switchover*.
3. The electric reheat is time modulated. This allows it to be controlled proportionally rather than with deadbands.
4. (Optional) The airflow is shown operating parallel with the electric heat. The airflow can operate at a minimum flow throughout the entire heating mode (default setting). See *Sequencing Logic*.

Hardware Inputs

Analog

- Room temperature sensor
- *(Optional)* Room temperature setpoint dial
- Spare sensor (two temperature) (100K or 10K Ω selectable thermistor) or Digital Input

Digital

- *(Optional)* Night mode override
- *(Optional)* Wall switch



NOTE:

Digital Room Units (Firmware Revision 26 and later) will update their controlled inputs without putting them Out Of Service. However, a command from an external source through the digital room unit will put the associated BACnet Input point Out Of Service.

Room Unit Identification

- For Analog Room Units (Series 1000) – The revision number is visually identified by its case.
- For Digital Room Units (Series 200/2300 Firmware Revision 25 or earlier) – The revision number displays for 5 seconds when the room unit is first powered up. These room units will display `laptop` when a laptop is connected and will no longer update room temperature sensor values.
- For Digital Room Units (Series 2200/2300 Firmware Revision 26 and later) – The revision number displays for 5 seconds when the room unit is first powered up or when a laptop is disconnected. These room units will continue to display and update the room temperature sensor values when a laptop is connected.

Hardware Outputs

Analog

- Spare Analog Output (0-10V)

Digital

- Damper actuator (internal)
- *(Optional)* Autozero Module
- *(Optional)* Autozero Module or spare DO 6
- Stage 1 electric heat or 2-position heating valve (or spare DO 3)
- *(Optional)* Stage 2 electric heat (or spare DO 4)
- *(Optional)* Stage 3 electric heat (or spare DO 5)

Ordering Notes

550-430PA	BACnet Actuating Terminal Equipment Controller (ATEC) 44 lb-in. (5 Nm)
550-431PA	BACnet Actuating Terminal Equipment Controller (ATEC) 88 lb-in (10 Nm)

Sequence of Operation

Control Temperature Setpoints

CTL STPT is Overridden

If CTL STPT is overridden, that value is used regardless of any other settings. This disables the setpoint deadband feature.

CTL STPT in Night Mode

The controller is in Night mode if DAY.NGT = NGT and NGT OVRD = NGT.

When the controller is in Night mode, CTL STPT holds the value of NGT CLG STPT or NGT HTG STPT depending on the value of HEAT.COOL. When the controller is in Night mode, the value of RM STPT DIAL is ignored.

CTL STPT in Day Mode

The controller is in Day mode if DAY.NGT = DAY or NGT OVRD = DAY.

Without setpoint dial:

When the controller is in Day mode and STPT DIAL = NO, CTL STPT holds the value of DAY CLG STPT or DAY HTG STPT, depending on the value of HEAT.COOL.

With setpoint dial:

When the controller is in Day mode and STPT DIAL = YES, CTL STPT holds a value based on RM STPT DIAL, depending on your room unit model/revision.

The following sections describe the value of CTL STPT based on room unit type and configuration:

- CTL STPT using Standard/Absolute Mode (Digital Room Unit, Revision 26 and later)
- CTL STPT using Warmer/Cooler Mode (Digital Room Unit, Revision 26 and later)
- CTL STPT using Standard/Absolute Mode (Analog or Digital Room Unit)
- CTL STPT using Warmer/Cooler Mode (Analog Room Unit Only)



NOTE:

If RM STPT DIAL is failed, it maintains the last known value.

CTL STPT Using Standard/Absolute Mode (Digital Room Unit, Revision 26 and later)

Digital Room Unit (2200/2300 Series Firmware Revision 26 and later)

For all new digital room units, the value displayed and reported by the room unit is linked to the current heat/cool mode. When the mode changes, the value is automatically updated based on the new heat/cool mode.

When STPT SPAN is set to 0, the room setpoint adjustment on the digital room unit functions in a standard mode. The range of the adjustment is based on RM STPT MIN and RM STPT MAX.

CTL STPT is set equal to RM STPT DIAL. The values for RM STPT MIN and RM STPT MAX are applied to limit RM STPT DIAL before it is copied into CTL STPT.

CTL STPT Using Warmer/Cooler Mode (Digital Room Unit, Revision 26 and later)

Digital Room Unit (2200/2300 Series Firmware Revision 26 and later)



NOTE:

The warmer-cooler function is only available with BACnet PTEC controllers (standard 66xx apps).

When STPT SPAN is set to a value > 0, the room setpoint adjustment on the digital room unit functions in a warmer/cooler mode. The range of the adjustment is calculated based on the current DAY CLG STPT or DAY HGT STPT and the STPT SPAN value. This will allow the Room Setpoint Dial to be incremented up or down from these setpoints by STPT SPAN.

CTL STPT is set equal to RM STPT DIAL. The values for RM STPT MIN and RM STPT MAX is applied to limit RM STPT DIAL before it is copied into CTL STPT.

When SPTP SPAN > 0, the minimum and maximum values for RM STPT DIAL are calculated as follows:

- Minimum lowest adjusted setpoint value is equal to DAY CLG STPT or DAY HTG STPT - STPT SPAN
- Maximum highest adjusted setpoint value is equal to DAY CLG STPT or DAY HTG STPT + STPT SPAN

Example in Cooling Mode

If the STPT SPAN is set to 2.0 degrees, and the DAY CLG STPT is 76°F, you can move the room unit setting up or down to adjust the RM STPT DIAL from 74°F to 78°F.

CTL STPT Using Standard/Absolute Mode (Analog or Digital Room Unit)

Analog (Series 1000) or Digital Room Units (Firmware Revision 25 or earlier)



NOTE:

2200/2300 digital room units with Firmware Revision 25 or earlier are only compatible with standard room unit functionality (no warmer/cooler).

When STPT SPAN is set to 0, CLT STPT is set based on the value of the setpoint dial and the setpoint deadband.

The setpoint deadband is the difference between the cooling and heating day setpoints (DAY CLG STPT DAY – HTG STPT). The setpoint deadband can be disabled by setting DAY HTG STPT equal to DAY CLG STPT. When DAY HTG STPT does not equal DAY CLG STPT, a setpoint deadband (or zero energy band) is used.

The following values are used in the calculation of CTL STPT:

- *Deadband* is the value of the difference between DAY CLG STPT and DAY HTG STPT and is used to establish the current heating and cooling setpoints.
- $Deadband = (DAY\ CLG\ STPT - DAY\ HTG\ STPT)$

CTL STPT is calculated as follows:

With Deadband disabled:

CTL STPT = RM STPT DIAL

With Deadband enabled in Heat Mode:

$$\text{CTL STPT} = \text{RM STPT DIAL} - 0.5 * \text{Deadband}$$

With Deadband enabled in Cool Mode:

$$\text{CTL STPT} = \text{RM STPT DIAL} + 0.5 * \text{Deadband}$$

CTL STPT is limited between the value of RM STPT MIN and RM STPT MAX

CTL STPT Using Warmer/Cooler Mode (Analog Room Unit Only)

Analog Room Unit (Series 1000)



NOTE:

The warmer-cooler function for analog room units (Series 1000) use the warmer/cooler scale of units with a warmer/cooler housing.

When SPTP SPAN > 0, the minimum and maximum values for RM STPT DIAL are calculated as follows:

- Minimum lowest adjusted setpoint value is equal to DAY CLG STPT or DAY HTG STPT - STPT SPAN
- Maximum highest adjusted setpoint value is equal to DAY CLG STPT or DAY HTG STPT + STPT SPAN

The full range of the analog room unit slider are mapped to a range of minimum setpoint value to maximum setpoint value.

CTL STPT is set equal to RM STPT DIAL. The values for RM STPT MIN and RM STPT MAX are applied to limit RM STPT DIAL before it is copied into CTL STPT.

Example in Cooling Mode

If the STPT SPAN is set to 2.0 degrees, and the DAY CLG STPT is 76°F, the room unit slider will adjust the cooling setpoint from 74°F to 78°F.

Heating/Cooling Switchover

If the following conditions are met for the length of time set in SWITCH TIME, the controller switches from heating to cooling mode by setting HEAT.COOL to COOL.

- HTG LOOPOUT < SWITCH LIMIT
- CTL TEMP > CTL STPT by at least the value set in SWITCH DBAND
- CTL TEMP > the appropriate cooling setpoint minus SWITCH DBAND

If the following conditions are met for the length of time set in SWITCH TIME, the controller switches from cooling to heating mode by setting HEAT.COOL to HEAT.

- CLG LOOPOUT < SWITCH LIMIT
- CTL TEMP < CTL STPT by at least the value set in SWITCH DBAND
- CTL TEMP < the appropriate heating setpoint minus SWITCH DBAND

When the STPT DIAL = NO, the heating/cooling switchover values are determined by DAY HTG STPT and DAY CLG STPT.

When the STPT DIAL = YES, the following sections describe the values used for the heating/cooling switchover points based on room unit type and configuration.

See the appropriate sections:

- Heating/Cooling Switchover Using Standard/Absolute Mode (Digital Room Unit, Revision 26 and later) [→ 12]
- Heating/Cooling Switchover Using Warmer/Cooler Mode (Digital Room Unit, Revision 26 and later) [→ 12]
- Heating/Cooling Switchover Using Standard/Absolute Mode (Analog Room Unit) [→ 13]
- Heating/Cooling Switchover Using Warmer/Cooler Mode (Analog Room Unit) [→ 13]

Heating/Cooling Switchover using Standard/Absolute Mode (Digital Room Unit, Revision 26 and later)

Recommended Configuration: Digital Room Units (2200/2300 Series Firmware Revision 26 and later)

For new digital room units, the graphic or actual value displayed and reported by the room unit is linked to the current heat/cool mode. When the mode changes, the value is automatically updated based on the new heat/cool mode.

- When the controller is in cooling mode, the heating switchover setpoint is as follows:
Heating switchover point is equal to $RM\ STPT\ DIAL - DAY\ CLG\ STPT + DAY\ HTG\ STPT$
- When the controller is in heating mode, the cooling switchover setpoint is as follows:
Cooling switchover point is equal to $RM\ STPT\ DIAL - DAY\ HTG\ STPT + DAY\ CLG\ STPT$

Example

DAY CLG STPT = 74 and DAY HTG STPT = 70

In Cooling mode, when you adjust the setpoint value on the room unit to 76, the heating switchover point will equal 72 - SWITCH DBAND.

Heating switchover point: $76 - 74 + 70 = 72 - SWITCH\ DBAND$

When the room temperature drops below heating switchover point and the switchover conditions are met, the controller switches to heating mode, the new value for the setpoint displays and RM STPT DIAL is 72 degrees.

Heating/Cooling Switchover Using Warmer/Cooler Mode (Digital Room Unit, Revision 26 and later)

Digital Room Unit (2200/2300 Series Firmware Revision 26 and later)

For new digital room units, the graphic or actual value displayed and reported by the room unit is linked to the current heat/cool mode. When the mode changes, the value is automatically updated based on the new heat/cool mode.

The RM STPT DIAL displays the current temperature setpoint based on a plus or minus position or increment that you enter at the room unit.

When SPTP SPAN > 0, the minimum and maximum values for RM STPT DIAL are calculated as follows:

- Minimum lowest adjusted setpoint value is equal to DAY CLG STPT or DAY HTG STPT - STPT SPAN
- Maximum highest adjusted setpoint value is equal to DAY CLG STPT or DAY HTG STPT + STPT SPAN

The heat/cool switchover mechanism is the same as in standard/absolute mode.

- When the controller is in cooling mode, the heating switchover setpoint is as follows:
Heating switchover point is equal to RM STPT DIAL – DAY CLG STPT + DAY HTG STPT
- When the controller is in heating mode, the cooling switchover setpoint is as follows:
Cooling switchover point is equal to RM STPT DIAL – DAY HTG STPT + DAY CLG STPT

Heating/Cooling Switchover Using Standard/Absolute Mode (Analog Room Unit)

Analog (Series 1000) or Digital Room Units (Firmware Revision 25 or earlier)

The difference between day heating and day cooling setpoint establishes the separation for heat/cool switchover points (deadband = DAY CLG STPT – DAY HTG STPT).

- When the controller is in Cooling mode, the heating switchover setpoint is as follows:
Heating switchover point is equal to RM STPT DIAL – 0.5 * the deadband
- When the controller is in Heating mode, the cooling switchover setpoint is as follows:
Cooling switchover point is equal to RM STPT DIAL + 0.5 * the deadband

Heating/Cooling Switchover Using Warmer/Cooler Mode (Analog Room Unit)

Analog Room Unit (Series 1000)

The RM STPT DIAL displays the current temperature setpoint based on a plus or minus position or increment that you enter at the room unit.

The amount of offset that can be entered with the analog room unit is limited to a value of minus STPT SPAN to plus STPT SPAN.

- When the controller is in Cooling mode, the heating switchover setpoint is as follows:
Heating switchover point is equal to DAY CLG STPT, plus the amount of offset entered
- When the controller is in Heating mode, the cooling switchover setpoint is as follows:
Cooling switchover point is equal to DAY HTG STPT, plus the amount of offset entered

Room Temperature, Room Temperature Offset and CTL TEMP

ROOM TEMP is the temperature that is being sensed by the room temperature sensor (RTS).

RMTMP OFFSET (or TEMP OFFSET) is a user-adjustable offset that compensates for deviations between the value of ROOM TEMP and the actual room temperature.

CTL TEMP is the room temperature that is used for control purposes. In other words, the application is trying to maintain CTL TEMP at the control setpoint.

When CTL TEMP is not overridden, CTL TEMP and ROOM TEMP are related by the following equation:

$$\text{CTL TEMP} = \text{ROOM TEMP} + \text{RMTMP OFFSET (or TEMP OFFSET)}$$

If CTL TEMP is not overridden then,

- The current value of ROOM TEMP (normal or overridden) determines the value of CTL TEMP.
- If ROOM TEMP has a status of Failed, then the last known good value of ROOM TEMP determines the value of CTL TEMP.

Day and Night Modes

The day/night status of the space is determined by the status of DAY.NGT. The control of this point differs depending on whether the controller is monitoring the status of a wall switch or if the controller is connected to a field panel.

When WALL SWITCH = NO, the controller does not monitor the status of the wall switch, even if one is connected to it. In this case, if the controller is operating stand-alone, then the controller stays in day mode all the time. If the controller is operating with centralized control (that is, it is connected to a field panel), then the field panel can send an operator or PPCL command to override the status of DAY.NGT.

When a wall switch is physically connected to the termination strip on the controller at AI/DI 4 (see the *Control Diagram* in the Overview section), and WALL SWITCH = YES, the controller monitors the status of AI/DI 4. When the status of AI/DI 4 is ON (the switch is closed), then DAY.NGT is set to DAY indicating that the controller is in Day mode. When the status of AI/DI 4 is OFF (the switch is open), then DAY.NGT is set to NIGHT indicating that the controller is in Night mode.

Night Mode Override Switch

If an override switch is present on the room temperature sensor and a value (in hours) other than zero has been entered into OVRD TIME, pressing the override switch resets the controller to DAY operational mode for the time period that is set in OVRD TIME.

The status of NGT OVRD changes to DAY. After the override time elapses, the controller returns to night mode and the status of NGT OVRD changes back to NIGHT.

The override switch on the room sensor only affects the controller when it is in Night mode.

Ventilation Demand Minimum

The additional flow setpoint (VENT DMD MIN) is provided to allow setting and adjustment of the ventilation air required during occupied modes. VENT DMD MIN flow setpoint is used in conjunction with the existing cooling and heating flow minimum setpoints but only during the occupied modes.

VENT DMD MIN can be set above, equal to, or below CLG FLOW MIN or HTG FLOW MIN setpoints and the controlling minimum is the greater of the two. This allows you to set the cooling flow minimum to be set to zero and use the vent demand to control cooling and heating ventilation requirements.

VENT DMD MIN can be controlled (reset) externally, or by PPCL in the controller, for ventilation demands as based on CO2 or other indoor air quality requirements. Minimum airflow is the greater of cooling flow minimum or heating flow minimum setpoints and the current ventilation demand flow setpoint. The control maximum flow setpoints are not affected by VENT DMD MIN.

Night Flow Minimum

Some applications do not provide a distinction between day/occupied and night/unoccupied modes for the minimum airflow setpoints. For day/occupied operation, the cooling minimum flow setpoint is designed to be the airflow for minimum cooling and ventilation. For night/unoccupied times, the associated air handling unit was typically not running and therefore no distinction was necessary.

Using the additional flow setpoint, NGT FLOW MIN, in place of cooling flow minimum, addresses this condition. Since the flow at night/unoccupied times does not require the ventilation needs for personnel, it can be set below other minimums or at zero. The configured maximum cooling flow setpoint is still used when the zone temperature exceeds the night cooling setpoint.

Control Loops

The controller is controlled by three Proportional, Integral, and Derivative (PID) control loops; two temperature loops and a flow loop.

The two temperature loops are a cooling loop and a heating loop. The active temperature loop maintains room temperature at the value in CTL STPT. See *Control Temperature Setpoints*.

Cooling Loop – The cooling loop generates cooling loopout which is then used to generate FLOW STPT. FLOW STPT is the result of scaling the cooling loopout to the appropriate range of values determined by flow minimum (CLG FLOW MIN) and flow maximum (CLG FLOW MAX).

The following figure describes how the flow setpoint is calculated:

$$\text{FLOW STPT} = [\text{CLG LOOPOUT} \times (100\% - \% \text{ minimum setpoint})] + \% \text{ minimum setpoint}$$

Where percent minimum setpoint is:

$$\% \text{ minimum setpoint} = (\text{CLG FLOW MIN} / \text{CLG FLOW MAX}) \times 100\%$$

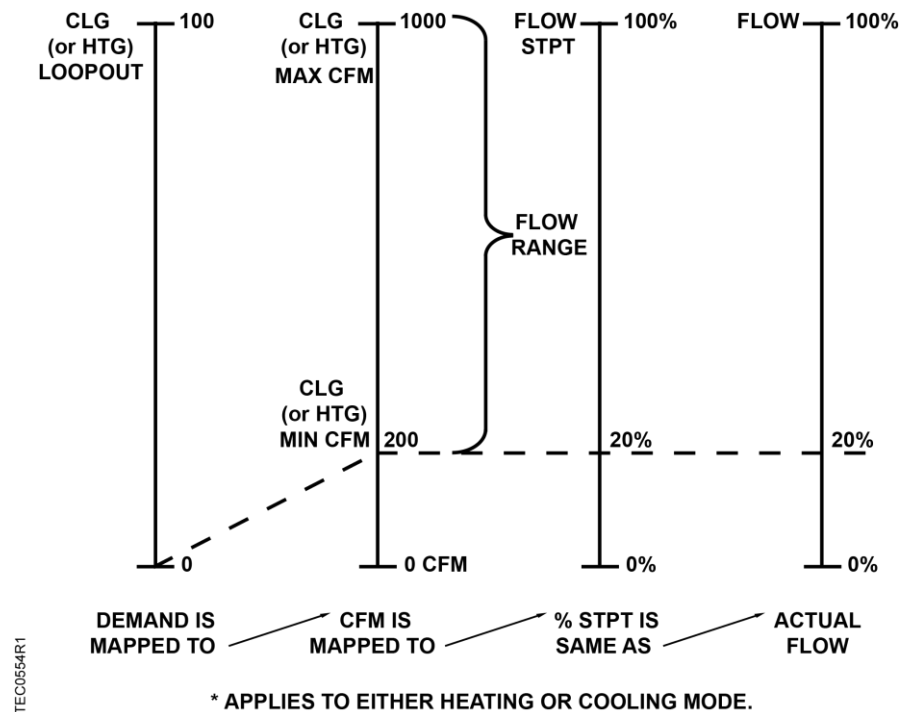

FLOW STPT and FLOW % are relative to MIN and MAX STPTS of corresponding heating or cooling mode.

Example

If CLG FLOW MIN = 200 cfm, and CLG FLOW MAX = 1000 cfm, the minimum flow setpoint is $(200 \text{ cfm}/1000 \text{ cfm}) \times 100\% \text{ flow} = 20\%$.

When CLG LOOPOUT is 0%, FLOW STPT = 20% flow.
 $[0\% \times (100\% - 20\%)] + 20\% = 20\%$

This ensures that the airflow out of the terminal box is no less than CLG FLOW MIN.

When CLG LOOPOUT is 50%, FLOW STPT = 60% flow.
 $[50\% \times (100\% - 20\%)] + 20\% = 60\%$

When CLG LOOPOUT is 100%, FLOW STPT = 100% flow.
 $[100\% \times (100\% - 20\%)] + 20\% = 100\%$

Heating Loop – If the controller is in heating mode, the operation of the flow loop is flexible. It can be set up to do one of the following:

- Option 1: Constantly maintain airflow out of the terminal box equal to CTL FLOW MIN.
- Option 2: Operate in sequence with the reheat.
- Option 3: Operate parallel with the reheat.
- Option 4: Overlap its operation with the operation of the electric reheat.

If Option 1 is chosen, HTG LOOPOUT controls the electric reheat in order to maintain the room temperature. If Options 2, 3, or 4 is chosen, HTG LOOPOUT controls both the flow loop setpoint (FLOW STPT) and the electric reheat in order to maintain the room temperature. See Sequencing Logic [→ 19] for more information.

HTG LOOPOUT adjusts the value of FLOW STPT differently depending on which flow loop setup is chosen. However, the following rule applies no matter what setup is chosen.

In heating mode, FLOW STPT is never set below $(\text{CTL FLOW MIN}/\text{HTG FLOW MAX}) \times 100\% \text{ flow}$ or above 100% flow.

In heating mode, CTL FLOW MIN is equal to HTG FLOW MIN.

Flow Loop – The flow loop maintains FLOW STPT by modulating the supply air damper, DMPR COMD. The flow loop maintains the airflow between CTL FLOW MIN and CTL FLOW MAX.

DAY/OCCUPIED MODE

When the controller is in day cooling mode:

- CTL FLOW MIN = larger of CLG FLOW MIN and VENT DMD MIN, and CTL FLOW MAX = CLG FLOW MAX.

When the controller is in day heating mode:

- CTL FLOW MIN = larger of HTG FLOW MIN and VENT DMD MIN, and CTL FLOW MAX = HTG FLOW MAX.

NIGHT/UNOCCUPIED MODE

When the controller is in night cooling mode:

- CTL FLOW MIN = NGT FLOW MIN, and CTL FLOW MAX = CLG FLOW MAX.

When the controller is in night heating mode:

- CTL FLOW MIN = NGT FLOW MIN, and CTL FLOW MAX = HTG FLOW MAX.

To enhance stable flow control, an advanced algorithm is used to calculate a controllable setpoint as the value approaches zero cfm (lps).

You can set CLG FLOW MIN equal to, but not greater than, CLG FLOW MAX. If the minimum and maximum values are set equal, the flow loop becomes a constant volume loop and loses its ability to control temperature.

FLOW is the input value for the flow loop. It is calculated as a percentage based on where AIR VOLUME is between 0 cfm and CTL FLOW MAX. This percentage is referred to as % flow.

- If AIR VOLUME = 0 cfm, FLOW is 0% flow.
- If AIR VOLUME = CTL FLOW MAX, FLOW is 100% flow.

The low limit of FLOW STPT is the percentage that corresponds to the volume given in CTL FLOW MIN. This percentage can be calculated as:

$$(CTL\ FLOW\ MIN/CTL\ FLOW\ MAX) \times 100\% \text{ flow}$$

The flow loop ensures that the supply air will not be less than CTL FLOW MIN.

Example

If CTL FLOW MIN = 250 cfm, and CTL FLOW MAX = 1000 cfm,
the low limit of FLOW STPT = (250 cfm/1000 cfm) × 100% flow
= 0.25 × 100% flow
= 25% flow.

Since 25% of 1000 cfm = 250 cfm, the minimum airflow out of the terminal box will be 250 cfm.

Staged Heating Coil - Terminal Unit



⚠ CAUTION

Verify that the equipment is supplied with safeties by others.

Ensure there is airflow across the heating coils when they are to be energized.

The heating loop controls up to three stages of electric reheat to warm up the room. The electric reheat is time modulated using a duty cycle as shown in the Table *Staged Heating*.

When the heating coil is located in the terminal unit, supply airflow is required to allow heat transfer from the coil to the room. EHEAT FLOW provides a means to ensure that there is sufficient airflow present before activating any heating stage.

If the flow setpoints for HTG MIN FLOW and HTG MAX FLOW results in a flow that is less than as set in EHEAT FLOW, the electric stages of heat will not be energized regardless of the heating demand. (For example, if HTG MAX FLOW is 1000 cfm and HTG MIN FLOW is 200 cfm, setting EHEAT FLOW to any percentage less than 20% will prevent activation of any heating stage.)

Whenever the stages of electric heat are energized, there must be sufficient airflow across the coils when they are located in the terminal unit. This can be from either the supply airflow (when the heating coils are located in the discharge of the terminal unit) or from the parallel terminal fan (required when the heating coils are in the return/plenum air path). See the section on Sequencing Logic [→ 19] (and Parallel Fan Operation) for options on controlling the heating coils with the terminal fan.

When the controller is in cooling mode, the electric heat is OFF at all times.

Example

When energized, the heating coils responds to the heating demand based on the configuration and duty cycle time.

If the duty cycle is 10 minutes (STAGE TIME = 10 minutes), and the heating loop is calling for 60% of heating (HTG LOOPOUT = 60%) for every 10-minute period, the stages of electric auxiliary heat cycle are as follows:

Staged Heating						
	Stage 1: minutes		Stage 2: minutes		Stage 3: minutes	
	ON	OFF	ON	OFF	ON	OFF
With 1 stage of electric heat	6	4	-	-	-	-
With 2 stages of electric heat	10	0	2	8	-	-
With 3 stages of electric heat	10	0	8	2	0	10

AVERAGE HEAT OUT

When the controller is in heating mode, AVG HEAT OUT indicates the percentage of the heating loop that is used for control and cycles the heating stages, independent of the number of stages enabled. The selected range for the heating stages (REHEAT START and REHEAT END) is applied to the HTG LOOPOUT to determine the AVG HEAT OUT.

For example, if REHEAT START = 0, and REHEAT END = 50%, then:

When HTG LOOPOUT = 0%, AVG HEAT OUT = 0%;

HTG LOOPOUT = 25%, AVG HEAT OUT = 50%

HTG LOOPOUT = 50% (or higher), AVG HEAT OUT = 100%

Staged Heating Coil - Baseboard Radiation

The application can be set up to control a 2-position heating coil or a stage of electric heat that is located outside of the air terminal unit. The staged heat is time modulated using a duty cycle as shown in the following example.

When the heating coil is external to the terminal unit (for example, baseboard radiation, perimeter heating coil or stage), airflow from the terminal unit is not required for the heat transfer to the room.

In this configuration, the setpoint for HTG FLOW MIN can be set (per job specification) for the required ventilation air. To prevent excessive cold air during heating, the maximum heating flow should also be set to this value (for example, HTG FLOW MAX = HTG FLOW MIN).

To ensure that the external heating can be activated by heating demand and not dependent on airflow, set the flow interlock, EHEAT FLOW, to a percentage value less than the HTG FLOW MIN. (For example, if HTG FLOW MIN = 200 and HTG FLOW MAX = 1000, set EHEAT FLOW to a percentage less than 20%, such as 15%, or, to allow it to operate with minimum interlock, set = 0%).

If the controller is in cooling mode, the heating stages will be off.

Sequencing Logic



NOTE:

Setting FLOW START = 0 and FLOW END = 100, provides modulating supply airflow during heating mode (HTG FLOW MIN to HTG FLOW MAX).

In heating mode, this application includes logic that allows the flow loop to operate in sequence, parallel, or overlapping with the heating device. Selected portions of the output of the heating loop, HTG LOOPOUT, will drive both the flow loop and the heating from 0 to 100%. See the *Examples* section.

- There is one stage of electric heat (STAGE COUNT = 1).
- The cycle time of the electric heat is 10 minutes (STAGE TIME = 10). (When this is done, FLOW STPT will equal 0 when HTG LOOPOUT = 0).

Examples

Example 1 (Airflow Sequenced First)

Assume that your system has electric heat that is to operate in sequence with the flow loop. If:

- FLOW START = 0%
- FLOW END = 50%
- REHEAT START = 50%
- REHEAT END = 100%

then,

- When HTG LOOPOUT = 0%, FLOW STPT will equal 0% flow.
- When HTG LOOPOUT = 25%, FLOW STPT will equal 50% flow.
- When HTG LOOPOUT ≥ 50%, FLOW STPT will equal 100% flow.
- When HTG LOOPOUT ≤ 50%, the electric heat will be off all the time.
- When HTG LOOPOUT = 75%, for every 10-minute period the electric heat will be on for 5 minutes and off for 5 minutes.
- When HTG LOOPOUT = 100%, the electric heat will be on all the time.

Example 2 (Airflow and Heat Sequenced Together)

Assume that your system has electric heat that is to operate in parallel with the flow loop. If:

- FLOW START = 0%
- FLOW END = 100%
- REHEAT START = 0%
- REHEAT END = 100%

then,

- When HTG LOOPOUT = 0%, FLOW STPT will equal 0% flow.
- When HTG LOOPOUT = 50%, FLOW STPT will equal 50% flow.
- When HTG LOOPOUT = 100%, FLOW STPT will equal 100% flow.
- When HTG LOOPOUT = 0%, the electric heat will be off all the time.
- When HTG LOOPOUT = 50%, for every 10-minute period the electric heat will be on for 5 minutes and off for 5 minutes.
- When HTG LOOPOUT = 100%, the electric heat will be on all the time.

Example 3 (Airflow Sequenced First with Overlap for Heating)

Assume that your system has electric heat that is to operate overlapping with the flow loop. If:

- FLOW START = 0%
- FLOW END = 75%
- REHEAT START = 25%
- REHEAT END = 100%

then,

- When HTG LOOPOUT = 0%, FLOW STPT will equal 0% flow.
- When HTG LOOPOUT = 37.5%, FLOW STPT will equal 50% flow.
- When HTG LOOPOUT \geq 75%, FLOW STPT will equal 100% flow.
- When HTG LOOPOUT \leq 25%, the electric heat will be off all the time.
- When HTG LOOPOUT = 62.5%, for every 10-minute period the electric heat will be on for 5 minutes and off for 5 minutes.
- When HTG LOOPOUT = 100%, the electric heat will be on all the time.

Another option that the sequencing logic provides is to have the flow loop provide an airflow equal to HTG FLOW MIN throughout the heating mode with all of the temperature control being done by the electric heat. The airflow minimum is maintained by setting the FLOW START and FLOW END to a value of 0%, resulting in the corresponding minimum flow throughout the entire heating mode, regardless of the value of HTG LOOPOUT. Example 4 clarifies this:

Example 4 (Airflow Remains Fixed; Heating Modulates)

If the job requirement specifies that the supply airflow in heating will remain fixed, set HTG FLOW MIN = HTG FLOW MAX so that the fixed value in heating is indicated. An alternative setting, would be to set FLOW START = FLOW MIN = 0, which would fix the flow at HTG FLOW MIN.

Assume that your system has electric heat that provides the temperature control in the heating mode, while the flow loop provides for the minimum air requirements.

- HTG FLOW MIN = 170 cfm
- HTG FLOW MAX = 1000 cfm
- STAGE COUNT = 1
- STAGE TIME = 10 minutes

If:

- FLOW START=0%
- FLOW END=0% (or/and HTG FLOW MIN = HTG FLOW MAX)
- REHEAT START = 0%
- REHEAT END = 100%

then,

- When HTG LOOPOUT = 0%, FLOW STPT will equal $(170 \text{ cfm}/1000 \text{ cfm}) \times 100\%$ flow = 17% flow. This will cause the flow loop to maintain an airflow of 170 cfm out of the terminal box.
- When HTG LOOPOUT = 50%, FLOW STPT will equal 17% flow.
- When HTG LOOPOUT = 100%, FLOW STPT will equal 17% flow.
- When HTG LOOPOUT = 0%, the electric heat will be off all the time.
- When HTG LOOPOUT = 50%, for every 10-minute period the electric heat will be on for 5 minutes and off for 5 minutes.
- When HTG LOOPOUT = 100%, the electric heat will be on all the time.

Electric Heat Interlock

Terminal unit heat stages

The electric heat stages will be enabled as long as $\text{FLOW} > \text{EHEAT FLOW}$. The electric heat stages will not be disabled (turned OFF) until $\text{FLOW} < \text{EHEAT FLOW} - 5\%$. Once disabled, FLOW must become greater than EHEAT FLOW before the electric heat stages will return to normal control.



⚠ CAUTION

Do not set EHEAT FLOW to less than 5%; otherwise, the electric heat interlock will be disabled.

Baseboard heat stage(s)

The electric or 2-position valve heat stages that are located outside the terminal unit do not require supply airflow. When there is only baseboard heating coils, the supply airflow interlock can be effectively disable ($\text{EHEAT FLOW} = 0$).

Calibration

Calibration of the controller's internal air velocity sensor(s) is periodically required to maintain accurate air velocity readings. CAL SETUP is set with the desired calibration option during controller startup.

Depending on the value of CAL SETUP, calibration may be set to take place automatically or manually. If CAL AIR = YES, calibration is in progress.

- For a controller used without an Autozero Module (CAL MODULE = NO), the damper is commanded closed to get a zero airflow reading during calibration.
- For a controller used with an Autozero Module (CAL MODULE = YES), calibration occurs without closing the damper.

At the end of a calibration sequence, CAL AIR automatically returns to NO. A status of NO indicates that the controller is not in a calibration sequence.

Floating Control Actuation Auto-correct

In addition to the existing options for floating control actuator full stroke actions, all floating control actuators are provided with additional logic to fully drive open or closed when commanded to 100% or 0%.

Room Unit Operation

Sensor Select

SENSOR SEL is a configurable, enumerated point (values are additive). This point tells the controller what type of room unit is being used and how to handle loss of communication, for more information see Fail Mode Operation. It also provides the ability to enable the optional RH and CO2 sensors and indicates which thermistor type is connected.

Room Temperature, Setpoint, RH and CO2

- When the digital room unit (Series 2200/2300) is used, SENSOR SEL selects the source for temperature and setpoint and enables a loss of communications indication:
 - 1 = enables supervision (from the room unit) for fail communications for temperature and setpoint.
 - 2 = enables supervision (from the room unit) for fail communications for relative humidity.
 - 4 = enables supervision (from the room unit) for fail communications for CO2.
- When the analog room unit (Series 1000/2000) is used, SENSOR SEL values for temperature/setpoint, relative humidity and CO2 should be left at their default values (0).

Thermistor Inputs

- Default for either input is 10K.
- To enable 100K Ω thermistor on input, see the following table for additive values.

SENSOR SEL Value * (additive)	Description (include values to enable feature)
1	Select Digital Room Unit (for temperature sensing and setpoint dial)
2	Relative Humidity (RH) sensing
4	CO ₂ sensing
8	100K Ω thermistor on AI 3 (or input is 10K Ω)
16	100K Ω thermistor on AI 4 (or input is 10K Ω)

Example 1: Digital Room Unit with temperature, RH, CO₂ and 10K thermistor.
1+2+4+0 = 7

Example 2: Analog Room unit with 100K thermistor. 0+0+0+8 = 8

Room CO₂

RM CO₂ displays the CO₂ value in units of parts-per-million (PPM). RM CO₂ (from the digital 2200/2300 room units) can be used with PPCL in the PTEC/ATEC controller or unbundled for control or monitoring purposes.

Room RH

RM RH displays the relative humidity value in percent. RM RH can be used for PPCL in the PTEC or unbundled for control or monitoring purposes.

RM RH displays the relative humidity value in percent.

Room DEW POINT

The controller provides a calculation for DEW POINT temperature in Fahrenheit degrees (or Celsius degrees) using room temperature (using CLT TEMP) and room humidity (using RM RH). This calculation is valid for ranges of 55°F (12.8°C) to 95°F (35°C) and 20 to 100% relative humidity.

Auto Discovery

Auto Discovery allows you to automatically discover and identify PTEC/ATEC controllers on the BACnet MS/TP Network. There are two basic configurations:

- Devices not configured with an address. (Devices are discovered by their unique serial number.)
- Devices configured with an address and available for modification.

Auto Addressing

Auto Addressing allows you to automatically assign device addresses to a PTEC/ATEC controller on the BACnet MS/TP Network. If a controller is not configured with a MAC address, you have the option to auto-address or manually address the controller. During this time the baud rate is automatically detected by the controller. Controller(s) must be connected on the BACnet/IP network in order for automatic addressing to occur.

PPCL STATUS

PPCL STATUS displays LOADED or EMPTY.

- LOADED = PPCL - programming is present in the controller. A new application number must be assigned (12000 through 12999).
- EMPTY = NO PPCL - programming is present.

The maximum number of PPCL dynamic points is 15.

Fail Mode Operation

If the air velocity sensor fails, the controller uses pressure dependent control. The temperature loop controls the operation of the damper.

If the room temperature sensor fails, the controller operates using the last known temperature value.

Performing the Automated Fault Detection and Diagnostics

VAV ATEC controllers have a built-in checkout procedure that performs a basic fault detection and diagnostic routine. It can be manually initiated at any time after the controller has been installed. This procedure tests all of the necessary I/O and ensures the controller can operate within the set airflow range, between CLG FLOW MIN and CLG FLOW MAX.

To perform the checkout procedure, set CHK OUT to **YES**. When the procedure has completed, CHK OUT returns to NO and the results display in CHK STATUS, Table *Possible Failure Value and Description*.

Possible Failure Value and Description	
CHK STATUS Values	Description
-1	Checkout procedure has not been run since last controller initialization.
0	No errors found.
1	RTS failed.
2	Room Setpoint dial failed (If STPT DIAL = YES).
4	AVS failed.
8	Controller could not reach CLG FLOW MIN or below.
16	Controller could not reach CLG FLOW MAX or above.
32	Controller did not read low (zero) flow when damper closed.

**NOTE:**

Multiple failures are added together and displayed as one value. For example, if the RTS failed (1) and the controller could not reach CLG FLOW MAX (16), CHK STATUS displays 17.

Failure codes indicate the following possible problems.

Room temperature sensor failed—CHK STATUS = 1

1. The cable for the room temperature sensor may be unplugged or loose. Check both ends to ensure that the cable is securely seated.
2. Connect directly to the controller through the room temperature sensor connection on the VAV Actuator and check whether communication is possible. If so, the problem lies in the room temperature sensor or its cable. If not, the problem is with the controller.
3. Contact your local Siemens Industry representative.

Room setpoint dial failed—CHK STATUS = 2

1. The cable for the room temperature sensor may be unplugged or loose. Check both ends to ensure that the cable is securely seated.
2. The controller may be incorrectly set to use a setpoint dial with a sensor that does not have the dial. If the sensor has no dial, change STPT DIAL from **YES** to **NO**.
3. Connect directly to the controller through the room temperature sensor connection on the VAV Actuator and check whether communication is possible. If so, the problem lies in the room temperature sensor or its cable. If not, the problem is with the controller.
4. Contact your local Siemens Industry representative.

Air velocity sensor failed—CHK STATUS = 4

1. The sensor tubing may be blocked, leaking, or disconnected. Check for pinched, disconnected, or cracked sensor tubing. Correct as needed.
2. The tubing connections for the air velocity sensor may be reversed. Re-pipe if HI and LO connections are incorrect.
3. The sensor or the VAV Actuator may be faulty.

Controller could not reach CLG FLOW MIN or below—CHK STATUS = 8

1. The actuator may be loose on the shaft. Check that the set screw is fully tightened against the damper shaft. Follow these torque guidelines:
 - 70 ± 5 inch pounds—solid metal
 - 37 ± 2 inch pounds—plastic, graphite, composite, or hollow metal (Hollow metal shafts require an insert to prevent shaft damage.)
2. The tubing for the air velocity sensor may be pinched, disconnected, or cracked. Check the tubing and correct as needed.

3. The tubing connections for the air velocity sensor may be reversed. Re-pipe if HI and LO connections are incorrect.
4. Box sizing information may be incorrect. Check the values of the following points and correct as needed:
 - DUCT AREA
 - FLOW COEFF
 - CLG FLOW MIN
 - CLG FLOW MAX
5. Motor setup information may be incorrect. Check the values of the following points and correct as needed:
 - MTR SETUP
 - MTR1 TIMING
 - DMPR ROT ANG
6. The box may not have been balanced correctly. Contact your local Siemens Industry representative.
7. The air velocity sensor may need calibration. Set CAL AIR to **YES** to run the calibration sequence. When CAL AIR returns to NO, indicating that the sequence is finished, run the checkout procedure again to see whether the problem has been corrected.

Controller could not reach CLG FLOW MAX or above—CHK STATUS = 16

1. Check for the problems described immediately above for CLG FLOW MIN.
2. The box may be starved for air, because either the central air-handling unit is off or there is low duct static.

Controller did not read low (zero) flow when damper closed—CHK STATUS = 32

1. Check for the problems described above for CLG FLOW MIN.
2. The damper shaft may not be secured correctly to the actuator so that when the actuator is fully closed, the damper does not completely shut off airflow.
3. Airflow calibration (at zero) may need to be performed ensuring the damper is fully closed and/or the air handling unit is off.

Application Notes

- If temperature swings in the room are excessive or there is trouble maintaining the setpoint, the cooling loop must be tuned. If FLOW is oscillating while FLOW STPT is constant, the flow loop requires tuning.
- The controller, as shipped from the factory, keeps all associated equipment OFF.
- Spare DOs can be used as auxiliary points that are controlled by the field panel after being defined in the field panel's database. DO 5 and DO 6 may be used as auxiliary motor points. If using a pair of spare DOs to control a motor, you must unbundle the corresponding motor command point.
- Spare DOs can be used as auxiliary points that are controlled by the field panel after being defined in the field panel's database. DO 3 and DO 4 or DO 5 and DO 6 may be used as auxiliary motor points. If using a pair of spare DOs to control a motor, you must unbundle the corresponding motor command point.

For more information, contact your local Siemens Industry representative.

Wiring Diagram



NOTE:

The controller's DOs control 24 Vac loads only. The maximum rating is 12 VA for each DO. An external interposing relay is required for any of the following:

- VA requirements higher than the maximum
- 110 or 220 Vac requirements
- DC power requirements
- Separate transformers used to power the load
(for example, part number 540-147, Terminal Equipment Controller Relay Module)

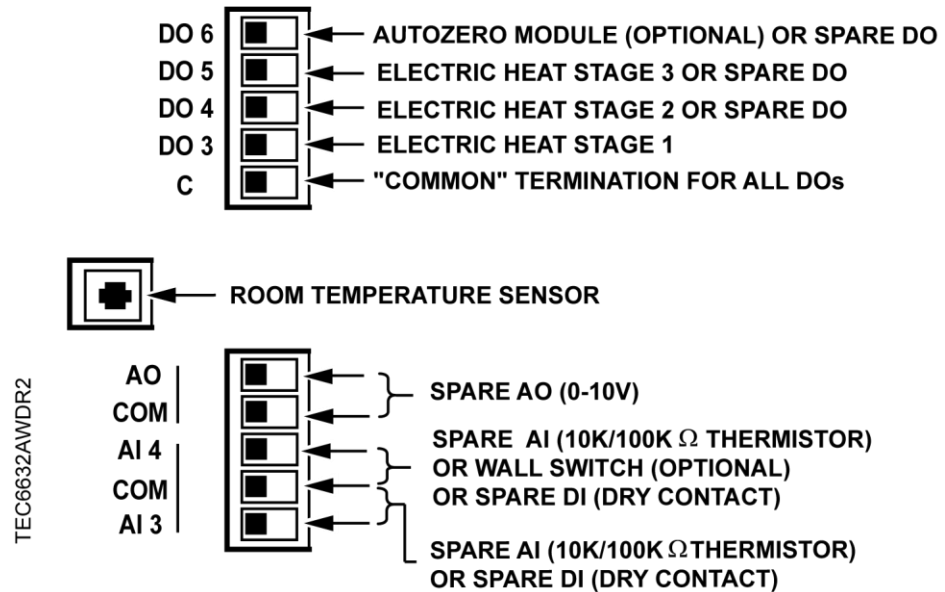

Application 6632 VAV with Electric Heat Wiring Diagram.

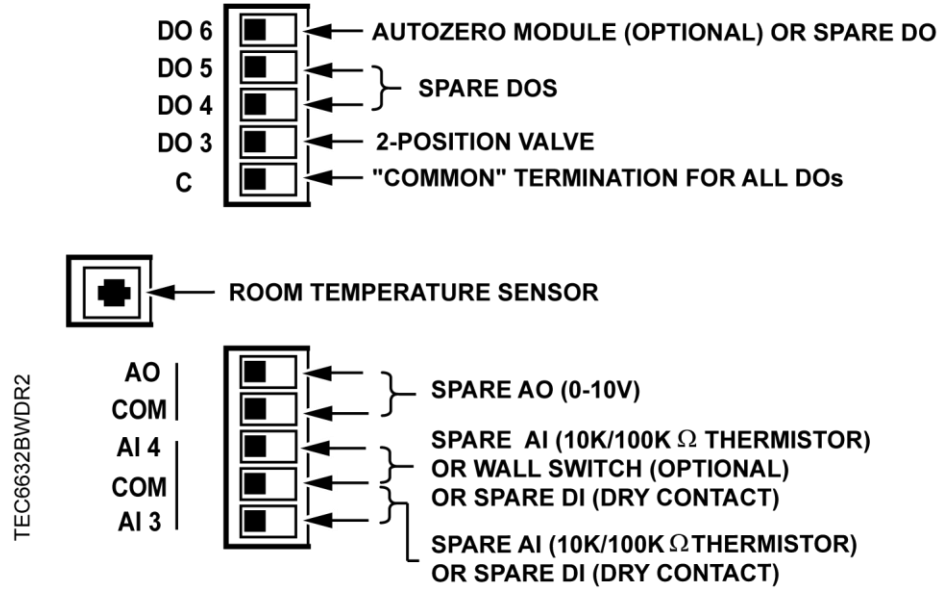

Application 6632 VAV with Baseboard Radiation Wiring Diagram.

Application 6632 Point Database

Object Type ¹⁾	Object Instance (Point Number)	Object Name (Descriptor)	Factory Default (SI Units) ²⁾	Eng Units (SI Units)	Range	Active Text	Inactive Text
AO	1	CTLR ADDRESS	255	--	0-255	--	--
AO	2	APPLICATION	6684	--	0-32767	--	--
AO	3	RMTMP OFFSET	0.0 (0.0)	DEG F (DEG C)	-31.75-32	--	--
AI	{04}	ROOM TEMP	74.0 (23.44888)	DEG F (DEG C)	48-111.75	--	--
BO	{05}	HEAT.COOL	COOL	--	Binary	HEAT	COOL
AO	6	DAY CLG STPT	74.0 (23.44888)	DEG F (DEG C)	48-111.75	--	--
AO	7	DAY HTG STPT	70.0 (21.20888)	DEG F (DEG C)	48-111.75	--	--
AO	8	NGT CLG STPT	82.0 (27.92888)	DEG F (DEG C)	48-111.75	--	--
AO	9	NGT HTG STPT	65.0 (18.40888)	DEG F (DEG C)	48-111.75	--	--
AO	{10}	DEW POINT	-40.0 (-40.0)	DEG F (DEG C)	-40-1598.35	--	--
AO	11	RM STPT MIN	55.0 (12.80888)	DEG F (DEG C)	48-111.75	--	--
AO	12	RM STPT MAX	90.0 (32.40888)	DEG F (DEG C)	48-111.75	--	--
AI	{13}	RM STPT DIAL	74.0 (23.44888)	DEG F (DEG C)	48-111.75	--	--
BO	14	STPT DIAL	NO	--	Binary	YES	NO
AI	{15}	AUX TEMP AI3	74.0 (23.495556)	DEG F (DEG C)	37.5-165	--	--
AO	16	FLOW START	0	PCT	0-102	--	--
AO	17	FLOW END	0	PCT	0-102	--	--
BO	18	WALL SWITCH	NO	--	Binary	YES	NO
BI	{19}	DI OVRD SW	OFF	--	Binary	ON	OFF
AO	20	OVRD TIME	0	HRS	0-255	--	--
BO	{21}	NGT OVRD	NIGHT	--	Binary	NIGHT	DAY
AO	22	REHEAT START	0	PCT	0-102	--	--
AO	23	REHEAT END	100	PCT	0-102	--	--
BI	{24}	DI 4	OFF	--	Binary	ON	OFF
BI	{25}	DI 3	OFF	--	Binary	ON	OFF
BO	{29}	DAY.NGT	DAY	--	Binary	NIGHT	DAY

Object Type ¹⁾	Object Instance (Point Number)	Object Name (Descriptor)	Factory Default (SI Units) ²⁾	Eng Units (SI Units)	Range	Active Text	Inactive Text
AO	31	CLG FLOW MIN	220 (103.818)	CFM (LPS)	0-131068	--	--
AO	32	CLG FLOW MAX	2200 (1038.18)	CFM (LPS)	0-131068	--	--
AO	33	HTG FLOW MIN	220 (103.818)	CFM (LPS)	0-131068	--	--
AO	34	HTG FLOW MAX	2200 (1038.18)	CFM (LPS)	0-131068	--	--
AI	{35}	AIR VOLUME	0 (0.0)	CFM (LPS)	0-131068	--	--
AO	36	FLOW COEFF	1	--	0-2.55	--	--
AO	{37}	MTR3 COMD	0	PCT	0-102	--	--
AO	{38}	MTR3 POS	0	PCT	0-102	--	--
AO	39	MTR3 TIMING	130	SEC	0-511	--	--
AO	40	NGT FLOW MIN	0 (0.0)	CFM (LPS)	0-131068	--	--
BO	{41}	DO 1	OFF	--	Binary	ON	OFF
BO	{42}	DO 2	OFF	--	Binary	ON	OFF
BO	{43}	HEAT STAGE 1	OFF	--	Binary	ON	OFF
BO	{44}	HEAT STAGE 2	OFF	--	Binary	ON	OFF
BO	{45}	HEAT STAGE 3	OFF	--	Binary	ON	OFF
BO	{46}	DO 6	OFF	--	Binary	ON	OFF
AO	{47}	VENT DMD MIN	0 (0.0)	CFM (LPS)	0-131068	--	--
AO	{48}	DMPR COMD	0	PCT	0-102	--	--
AO	{49}	DMPR POS	0	PCT	0-102	--	--
AI	{50}	AI 4	74.0 (23.495556)	DEG F (DEG C)	37.5-165	--	--
AO	51	MTR1 TIMING	95	SEC	0-511	--	--
AO	54	STPT SPAN	0.0 (0.0)	DEG F (DEG C)	0-63.75	--	--
AO	56	DMPR ROT ANG	90	--	0-255	--	--
AO	58	MTR SETUP	0	--	0-255	--	--
AO	59	DO DIR. REV	0	--	0-255	--	--
AO	60	EHEAT FLOW	20	PCT	0-102	--	--
AO	63	CLG P GAIN	20.0 (36.0)	--	0-63.75	--	--
AO	64	CLG I GAIN	0.01 (0.018)	--	0-1.023	--	--
AO	65	CLG D GAIN	0 (0.0)	--	0-510	--	--
BO	{66}	CHK OUT	NO	--	Binary	YES	NO
AO	67	HTG P GAIN	10.0 (18.0)	--	0-63.75	--	--
AO	68	HTG I GAIN	0.01 (0.018)	--	0-1.023	--	--

Object Type ¹⁾	Object Instance (Point Number)	Object Name (Descriptor)	Factory Default (SI Units) ²⁾	Eng Units (SI Units)	Range	Active Text	Inactive Text
AO	69	HTG D GAIN	0 (0.0)	--	0-510	--	--
AO	{70}	CHK STATUS	-1	--	-1-32766	--	--
AO	71	FLOW P GAIN	0	--	0-51.15	--	--
AO	72	FLOW I GAIN	0.01	--	0-1.023	--	--
AO	73	FLOW D GAIN	0	--	0-510	--	--
AO	74	FLOW BIAS	50	PCT	0-102	--	--
AO	{75}	FLOW	0	PCT	0-1023.75	--	--
AO	{76}	CTL FLOW MIN	220 (103.818)	CFM (LPS)	0-131068	--	--
AO	{77}	CTL FLOW MAX	2200 (1038.18)	CFM (LPS)	0-131068	--	--
AO	{78}	CTL TEMP	74.0 (23.44888)	DEG F (DEG C)	48-111.75	--	--
AO	{79}	CLG LOOPOUT	0	PCT	0-102	--	--
AO	{80}	HTG LOOPOUT	0	PCT	0-102	--	--
AO	{81}	AVG HEAT OUT	0	PCT	0-409.2	--	--
AO	82	STAGE MAX	90	PCT	0-102	--	--
AO	83	STAGE MIN	10	PCT	0-102	--	--
AO	{84}	AOV 1	0	VOLTS	0-10.23	--	--
AO	85	SWITCH LIMIT	5.2	PCT	0-102	--	--
AO	86	SWITCH TIME	10	MIN	0-255	--	--
BO	87	CAL MODULE	NO	--	Binary	YES	NO
AO	88	STAGE COUNT	1	--	0-255	--	--
AO	89	STAGE TIME	10	MIN	0-255	--	--
AO	90	SWITCH DBAND	1.0 (0.56)	DEG F (DEG C)	0-63.75	--	--
AO	{92}	CTL STPT	74.0 (23.44888)	DEG F (DEG C)	48-111.75	--	--
AO	{93}	FLOW STPT	0	PCT	0-255.75	--	--
BO	{94}	CAL AIR	NO	--	Binary	YES	NO
AO	95	CAL SETUP	4	--	0-255	--	--
AO	96	CAL TIMER	12	HRS	0-255	--	--
AO	97	DUCT AREA	1.0 (0.09292)	SQ. FT (SQ M)	0-6.375	--	--
AO	98	LOOP TIME	5	SEC	0-255	--	--
AO	{99}	ERROR STATUS	0	--	0-255	--	--
AO	124	SENSOR SEL	0	--	0-255	--	--
AI	{125}	RM CO2	1000	PPM	0-8191	--	--

Object Type ¹⁾	Object Instance (Point Number)	Object Name (Descriptor)	Factory Default (SI Units) ²⁾	Eng Units (SI Units)	Range	Active Text	Inactive Text
AI	{126}	RM RH	50	PCT	0-102	--	--
BO	{127}	PPCL STATE	EMPTY	--	Binary	LOADED	EMPTY

¹⁾ Object Types are; Analog Input (AI), Analog Output (AO), Binary Input (BI) and Binary Output (BO).

²⁾ A single value in a column means that the value is the same in English units and in SI units.

³⁾ Point numbers that appear in brackets { } may be unbundled at the field panel.

Issued by
Siemens Industry, Inc.
Building Technologies Division
1000 Deerfield Pkwy
Buffalo Grove IL 60089
Tel. +1 847-215-1000

© Siemens Industry, Inc., 2017
Technical specifications and availability subject to change without notice.