

# SIEMENS



## BACnet PTEC Controller

Terminal Box (VAV) - Electric  
Reheat or Baseboard Radiation,  
Application 6602

Application Note



# Table of Contents

<b>Overview .....</b>	<b>5</b>
BACnet .....	8
Hardware Inputs .....	8
Room Unit Identification .....	9
Hardware Outputs.....	9
Ordering Notes .....	9
<b>Sequence of Operation .....</b>	<b>10</b>
Control Temperature Setpoints .....	10
CTL STPT Using Standard/Absolute Mode (Digital Room Unit, Revision 26 and later) .....	10
CTL STPT Using Warmer/Cooler Mode (Digital Room Unit, Revision 26 and later) .....	11
CTL STPT Using Standard/Absolute Mode (Analog or Digital Room Unit) .....	11
CTL STPT Using Warmer/Cooler Mode (Analog Room Unit Only) .....	12
Heating/Cooling Switchover.....	12
Heating/Cooling Switchover using Standard/Absolute Mode (Digital Room Unit, Revision 26 and later) .....	13
Heating/Cooling Switchover Using Warmer/Cooler Mode (Digital Room Unit, Revision 26 and later) .....	13
Heating/Cooling Switchover Using Standard/Absolute Mode (Analog Room Unit).....	14
Heating/Cooling Switchover Using Warmer/Cooler Mode (Analog Room Unit)	14
Room Temperature, Room Temperature Offset and CTL TEMP .....	14
Day and Night Modes .....	15
Night Mode Override Switch .....	15
Ventilation Demand Minimum.....	15
Night Flow Minimum .....	16
Modulating Damper During Heating Mode (Optional) .....	16
Control Loops .....	16
Staged Heating Coil - Terminal Unit .....	18
Staged Heating Coil - Baseboard Radiation.....	19
Sequencing Logic .....	19
Electric Heat Interlock.....	21
Calibration.....	21
Room Unit Operation .....	22
Sensor Select .....	22
Room CO2.....	23
Room RH.....	23
Room DEW POINT .....	23
Auto Discovery.....	23

Auto Addressing.....	23
PPCL STATUS .....	24
Fail Mode Operation .....	24
Application Notes .....	24
Wiring Diagram .....	24
<b>Application 6602 Point Database .....</b>	<b>28</b>

# Overview



**NOTE:**

For information on applications with Firmware Revision Bx40 or earlier, see InfoLink and/or Asset Portal for documentation.

In Application 6602, the controller modulates the supply air damper of the terminal box for cooling and controls stages of electric reheat or baseboard radiation for heating. When in heating, the terminal box either maintains minimum airflow or modulates the supply air damper. In order for the terminal box to work properly, the central air-handling unit must provide supply air.

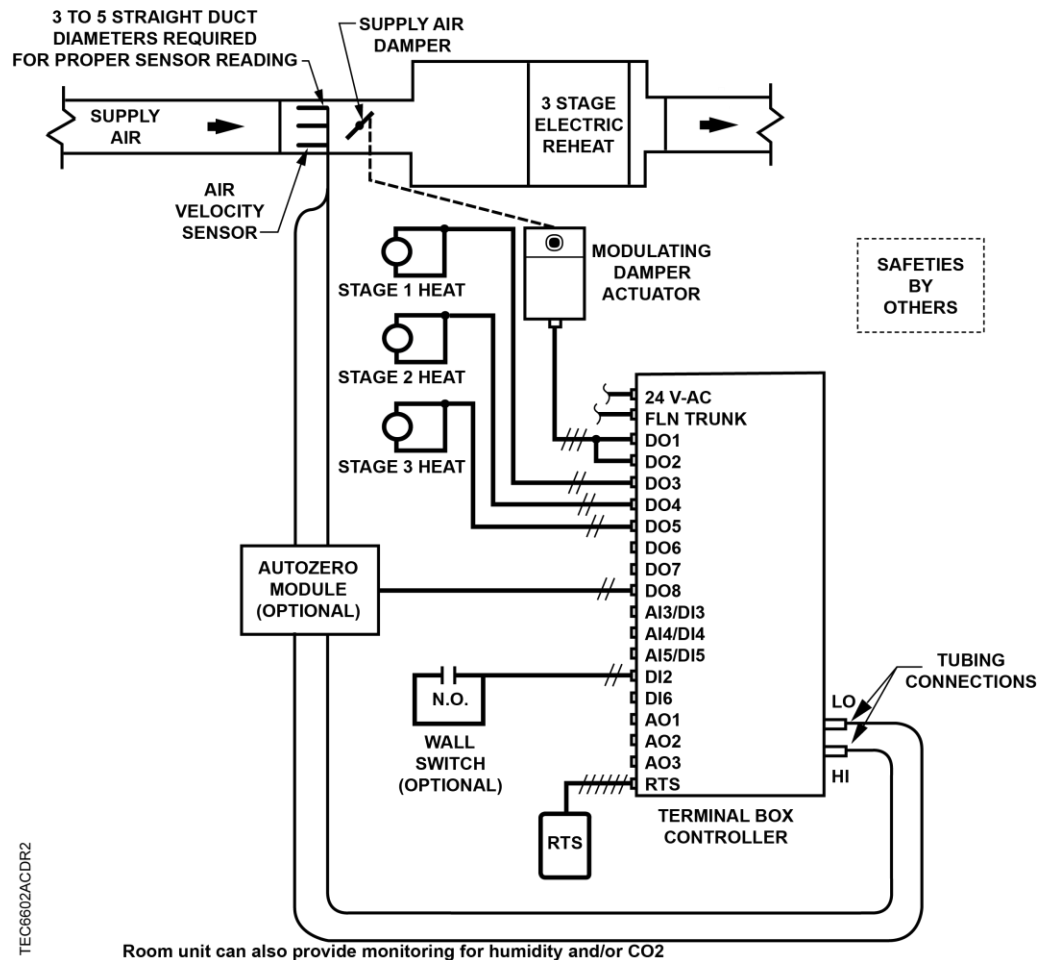

Application 6602 - VAV with 3-Stage Electric Heat Control Diagram.

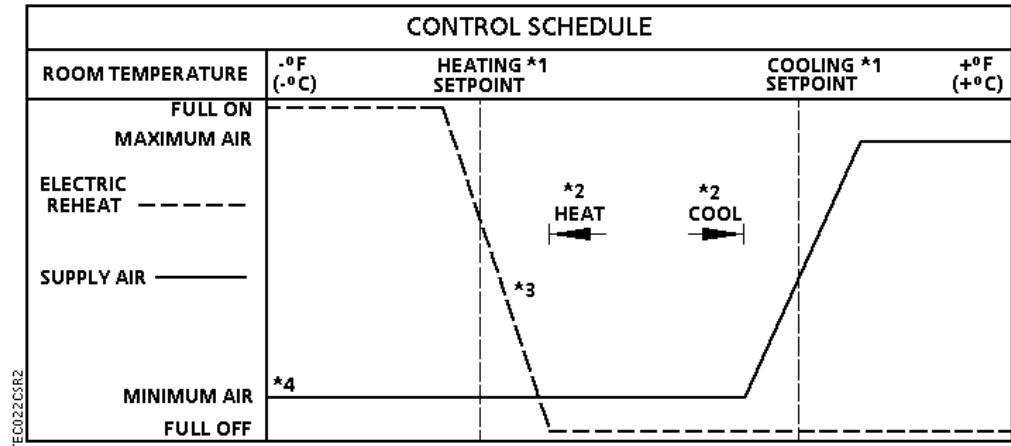

Application 6602 Control Schedule.

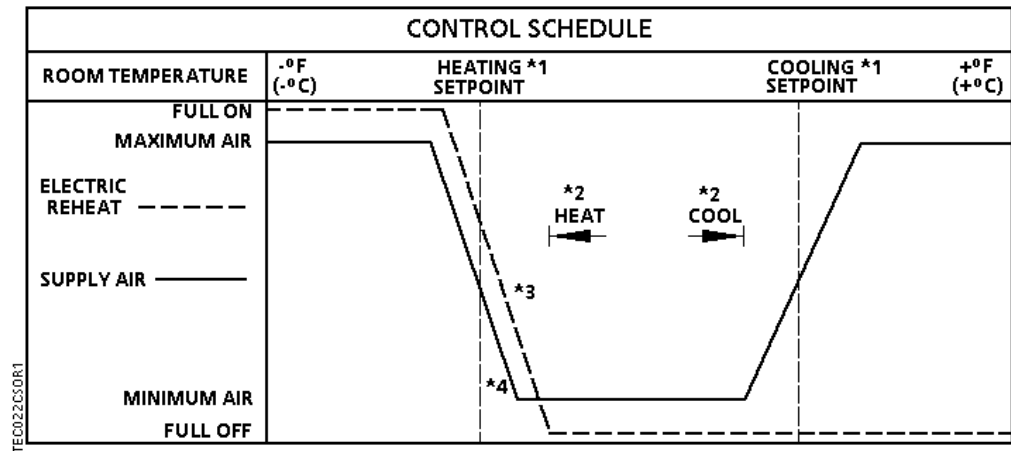

Application 6602 Heating Mode Control Schedule.



**NOTES:**

1. See *Control Temperature Setpoints*.
2. See *Heating/Cooling Switchover*.
3. The electric reheat is time modulated. This allows it to be controlled proportionally rather than with deadbands.
4. The airflow is shown modulating in the entire heating mode. (Default settings must be changed.) The airflow can operate sequenced, parallel, or overlapping with the electric reheat (optional). See *Sequencing Logic*.



**NOTE:**

The airflow is shown operating parallel with the electric reheat (optional). See *Sequencing Logic* [→ 19].

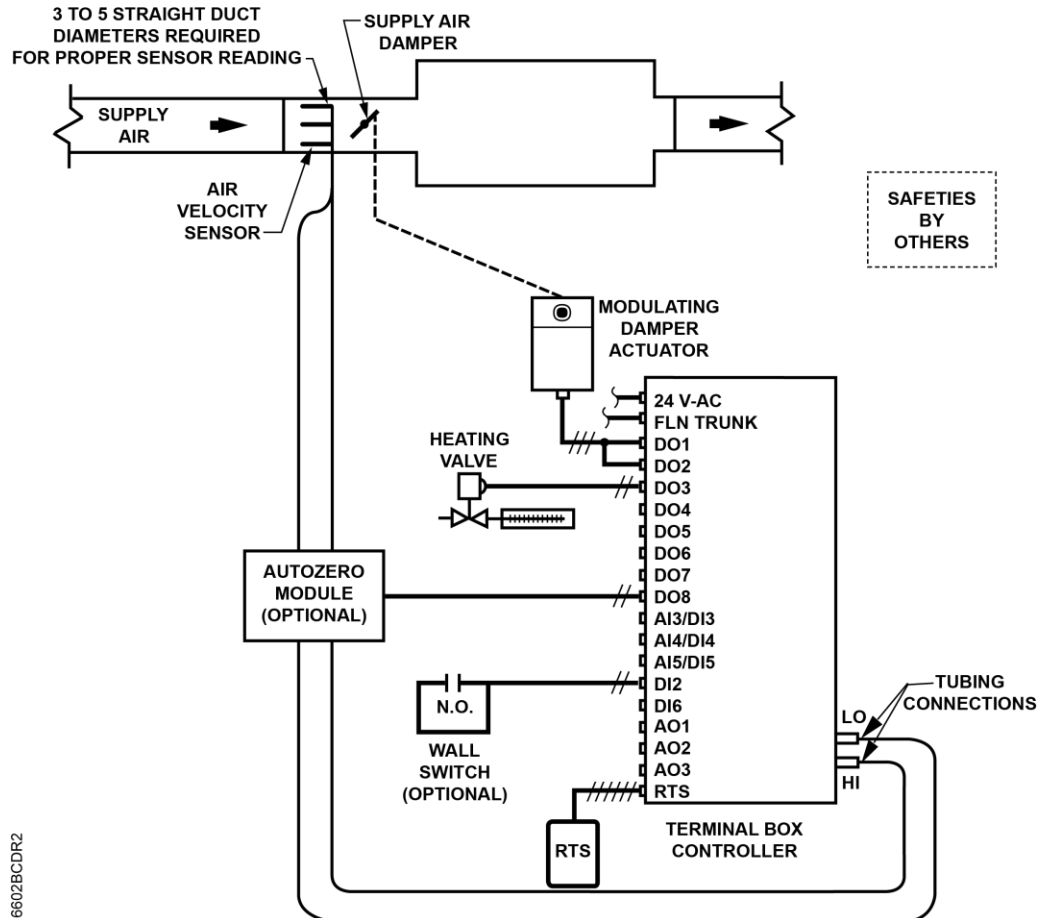

Room unit can also provide monitoring for humidity and/or CO2

Application 6602 - VAV with Baseboard Radiation.

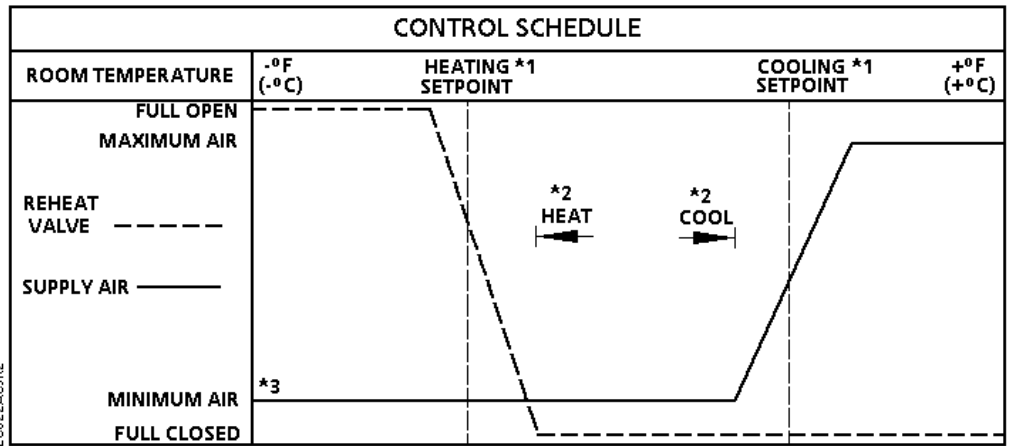

Application 6602 Control Schedule.



**NOTES:**

1. See *Control Temperature Setpoints*.
2. See *Heating/Cooling Switchover*.
3. The 2-position reheat valve is time modulated. This allows it to be controlled proportionally rather than with deadbands.
4. The airflow is shown at minimum flow in the entire heating mode (default setting, with FLOW START and FLOW END = 0). The airflow can operate sequenced, parallel, or overlapping with the electric reheat (optional). See *Sequencing Logic*.

## BACnet

The controller communicates using BACnet MS/TP protocol for open communications on BACnet MS/TP networks.

Product	Supported BIBBs	BIBB Name
BTEC/PTEC	DS-RP-B B	Data Sharing-Read Property-B
	DS-RPM-B	Data Sharing-Read Property Multiple-B
	DS-WP-B	Data Sharing-Write Property-B
	DM-DDB-B	Device Management-Dynamic Device Binding-B
	DM-DOB-B	Device Management-Dynamic Object Binding-B
	DM-DCC-B	Device Management-Device Communication Control-B
	DM-RD-B	Device Management-Reinitialize Device-B
	DM-BR-B	Device Management-Backup and Restore-B
	DM-OCD-B	Device Management-Object Creation and Deletion-B
	CPT	Confirmed Private Transfer (Auto Discovery)
	UPT	Unconfirmed Private Transfer

## Hardware Inputs

### Analog

- Air velocity sensor
- Room temperature sensor
- Room temperature setpoint dial (optional)
- Spare temperature sensor (two) (100K or 10K selectable thermistor)
- Spare analog sensor (0-10Vdc or 4-20mA)

### Digital

- Night/Unoccupied mode override (optional)
- Wall switch (optional)
- Spare DI



**NOTE:**

Digital Room Units (Firmware Revision 26 and later) will update their controlled inputs without putting them Out Of Service. However, a command from an external source through the digital room unit will put the associated BACnet Input point Out Of Service.

## Room Unit Identification

- For Analog Room Units – The revision number is visually identified by its case.
- For Digital Room Units (Firmware Revision 25 or earlier) – The revision number displays for 5 seconds when the room unit is first powered up. These room units will display `laptop` when a laptop is connected and will no longer update room temperature sensor values.
- For Digital Room Units (Firmware Revision 26 and later) – The revision number displays for 5 seconds when the room unit is first powered up or when a laptop is disconnected. These room units will continue to display and update the room temperature sensor values when a laptop is connected.

## Hardware Outputs

### Analog

- Spare AO 1, AO 2, and AO 3 (0-10V)

### Digital

- Damper actuator (DO 1/DO 2)
- Autozero module (optional) (DO 8)
- Stage 1 electric heat or 2-position heating valve (or Spare DO 3)
- Stage 2 electric heat (optional) (or Spare DO 4)
- Stage 3 electric heat (optional) (or Spare DO 5)
- Spare DOs

## Ordering Notes

550-495PA      BACnet PTEC Terminal Box (VAV) Controller

## Sequence of Operation

The following paragraphs present the sequence of operation for Application 6602, VAV with Electric Heat or Baseboard Radiation.

## Control Temperature Setpoints

### CTL STPT is Overridden:

If CTL STPT is overridden, that value is used regardless of any other settings. This disables the setpoint deadband feature.

### CTL STPT in Night Mode:

The controller is in Night Mode if DAY.NGT = NGT and NGT OVRD = NGT.

When the controller is in night mode, CTL STPT holds the value of NGT CLG STPT or NGT HTG STPT depending on the value of HEAT.COOL. When the controller is in night mode, the value of RM STPT DIAL is ignored.

### CTL STPT in Day Mode:

The controller is in Day Mode if DAY.NGT = DAY or NGT OVRD = DAY.

#### Without setpoint dial:

When the controller is in day mode and STPT DIAL = NO, CTL STPT holds the value of DAY CLG STPT or DAY HTG STPT depending on the value of HEAT.COOL.

#### With setpoint dial:

When the controller is in day mode and STPT DIAL = YES, CTL STPT holds a value based on RM STPT DIAL depending on your room unit model/revision.

The following sections describe the value of CTL STPT based on room unit type and configuration:

- CTL STPT using Standard/Absolute Mode (Digital Room Unit, Revision 26 and later)
- CTL STPT using Warmer/Cooler Mode (Digital Room Unit, Revision 26 and later)
- CTL STPT using Standard/Absolute Mode (Analog or Digital Room Unit)
- CTL STPT using Warmer/Cooler Mode (Analog Room Unit Only)



---

#### NOTE:

If RM STPT DIAL is failed, it maintains the last known value.

---

## CTL STPT Using Standard/Absolute Mode (Digital Room Unit, Revision 26 and later)

### Digital Room Unit (2200/2300 Series Firmware Revision 26 and later)

For all new digital room units, the value displayed and reported by the room unit is linked to the current heat/cool mode. When the mode changes, the value is automatically updated based on the new heat/cool mode.

When STPT SPAN is set to 0, the room setpoint adjustment on the digital room unit will function in a standard mode. The range of the adjustment will be based on RM STPT MIN and RM STPT MAX.

CTL STPT is set equal to RM STPT DIAL. The values for RM STPT MIN and RM STPT MAX will be applied to limit RM STPT DIAL before it is copied into CTL STPT.

## CTL STPT Using Warmer/Cooler Mode (Digital Room Unit, Revision 26 and later)

### Digital Room Unit (2200/2300 Series Firmware Revision 26 and later)



**NOTE:**

The warmer-cooler function is only available with BACnet PTEC controllers (standard 66xx apps).

When STPT SPAN is set to a value > 0, the room setpoint adjustment on the digital room unit will function in a warmer/cooler mode. The range of the adjustment will be calculated based on the current DAY CLG STPT or DAY HGT STPT and the STPT SPAN value. This will allow the Room Setpoint Dial to be incremented up or down from these setpoints by STPT SPAN.

CTL STPT is set equal to RM STPT DIAL. The values for RM STPT MIN and RM STPT MAX will be applied to limit RM STPT DIAL before it is copied into CTL STPT.

When SPTP SPAN > 0, the minimum and maximum values for RM STPT DIAL are calculated as follows:

- Minimum lowest adjusted setpoint value is equal to DAY CLG STPT or DAY HTG STPT - STPT SPAN
- Maximum highest adjusted setpoint value is equal to DAY CLG STPT or DAY HTG STPT + STPT SPAN

**Example in Cooling Mode**

If the STPT SPAN is set to 2.0 degrees, and the DAY CLG STPT is 76°F, you can step up or down the room unit to adjust the RM STPT DIAL from 74°F to 78°F.

## CTL STPT Using Standard/Absolute Mode (Analog or Digital Room Unit)

### Analog (Series 1000) or Digital Room Units (Firmware Revision 25 or earlier)



**NOTE:**

2200/2300 digital room units with Firmware Revision 25 or earlier are only compatible with standard room unit functionality (no warmer/cooler).

When STPT SPAN is set to 0, CLT STPT is set based on the value of the setpoint dial and the setpoint deadband.

The setpoint deadband is the difference between the cooling and heating day setpoints (DAY CLG STPT DAY – HTG STPT). The setpoint deadband can be disabled by setting DAY HTG STPT equal to DAY CLG STPT. When DAY HTG STPT does not equal DAY CLG STPT, a setpoint deadband (or zero energy band) is used.

The following values are used in the calculation of CTL STPT:

- *Deadband* is the value of the difference between DAY CLG STPT and DAY HTG STPT and is used to establish the current heating and cooling setpoints.
- $Deadband = (DAY\ CLG\ STPT - DAY\ HTG\ STPT)$

CTL STPT is calculated as follows:

**With Deadband disabled:**

$$\text{CTL STPT} = \text{RM STPT DIAL}$$

**With Deadband enabled in Heat Mode:**

$$\text{CTL STPT} = \text{RM STPT DIAL} - 0.5 * \text{Deadband}$$

**With Deadband enabled in Cool Mode:**

$$\text{CTL STPT} = \text{RM STPT DIAL} + 0.5 * \text{Deadband}$$

CTL STPT is limited between the value of RM STPT MIN and RM STPT MAX

## CTL STPT Using Warmer/Cooler Mode (Analog Room Unit Only)

### Analog Room Unit (Series 1000)



**NOTE:**

The warmer-cooler function for analog room units (Series 1000) use the warmer/cooler scale of units with a warmer/cooler housing.

When SPTP SPAN > 0, the minimum and maximum values for RM STPT DIAL are calculated as follows:

- Minimum lowest adjusted setpoint value is equal to DAY CLG STPT or DAY HTG STPT - STPT SPAN
- Maximum highest adjusted setpoint value is equal to DAY CLG STPT or DAY HTG STPT + STPT SPAN

The full range of the analog room unit slider will be mapped to a range of minimum setpoint value to maximum setpoint value.

CTL STPT is set equal to RM STPT DIAL. The values for RM STPT MIN and RM STPT MAX will be applied to limit RM STPT DIAL before it is copied into CTL STPT.

#### Example in Cooling Mode

If the STPT SPAN is set to 2.0 degrees, and the DAY CLG STPT is 76°F, the room unit slider will adjust the cooling setpoint from 74°F to 78°F.

## Heating/Cooling Switchover

If the following conditions are met for the length of time set in SWITCH TIME, the controller switches from heating to cooling mode by setting HEAT.COOL to COOL.

- HTG LOOPOUT < SWITCH LIMIT
- CTL TEMP > CTL STPT by at least the value set in SWITCH DBAND
- CTL TEMP > the appropriate cooling setpoint minus SWITCH DBAND

If the following conditions are met for the length of time set in SWITCH TIME, the controller switches from cooling to heating mode by setting HEAT.COOL to HEAT.

- CLG LOOPOUT < SWITCH LIMIT
- CTL TEMP < CTL STPT by at least the value set in SWITCH DBAND
- CTL TEMP < the appropriate heating setpoint minus SWITCH DBAND

When the STPT DIAL = NO, the heating/cooling switchover values are determined by DAY HTG STPT and DAY CLG STPT.

When the STPT DIAL = YES, the following sections describe the values used for the heating/cooling switchover points based on room unit type and configuration.

See the appropriate sections:

- Heating/Cooling Switchover Using Standard/Absolute Mode (Digital Room Unit, Revision 26 and later) [→ 13]
- Heating/Cooling Switchover Using Warmer/Cooler Mode (Digital Room Unit, Revision 26 and later) [→ 13]
- Heating/Cooling Switchover Using Standard/Absolute Mode (Analog Room Unit) [→ 14]
- Heating/Cooling Switchover Using Warmer/Cooler Mode (Analog Room Unit) [→ 14]

## Heating/Cooling Switchover using Standard/Absolute Mode (Digital Room Unit, Revision 26 and later)

### Recommended Configuration: Digital Room Units (2200/2300 Series Firmware Revision 26 and later)

For new digital room units, the graphic or actual value displayed and reported by the room unit is linked to the current heat/cool mode. When the mode changes, the value is automatically updated based on the new heat/cool mode.

- When the controller is in cooling mode, the heating switchover setpoint is as follows:  
Heating switchover point is equal to  $RM\ STPT\ DIAL - DAY\ CLG\ STPT + DAY\ HTG\ STPT$
- When the controller is in heating mode, the cooling switchover setpoint is as follows:  
Cooling switchover point is equal to  $RM\ STPT\ DIAL - DAY\ HTG\ STPT + DAY\ CLG\ STPT$

#### Example

$DAY\ CLG\ STPT = 74$  and  $DAY\ HTG\ STPT = 70$

In cooling mode, when the user adjusts the setpoint value on the room unit to 76, the heating switchover point will equal 72 - SWITCH DBAND.

Heating switchover point:  $76 - 74 + 70 = 72 - SWITCH\ DBAND$

When the room temperature drops below heating switchover point and the switchover conditions are met, the controller switches to heating mode, the new value for the setpoint displays and RM STPT DIAL is 72 degrees.

## Heating/Cooling Switchover Using Warmer/Cooler Mode (Digital Room Unit, Revision 26 and later)

### Digital Room Unit (2200/2300 Series Firmware Revision 26 and later)

For new digital room units, the graphic or actual value displayed and reported by the room unit is linked to the current heat/cool mode. When the mode changes, the value is automatically updated based on the new heat/cool mode.

The RM STPT DIAL will display the current temperature setpoint based on a plus or minus position or increment entered by the user at the room unit.

When SPTP SPAN > 0, the minimum and maximum values for RM STPT DIAL are calculated as follows:

- Minimum lowest adjusted setpoint value is equal to DAY CLG STPT or DAY HTG STPT - STPT SPAN
- Maximum highest adjusted setpoint value is equal to DAY CLG STPT or DAY HTG STPT + STPT SPAN

The heat/cool switchover mechanism is the same as in standard/absolute mode.

- When the controller is cooling mode, the heating switchover setpoint is as follows:  
Heating switchover point is equal to RM STPT DIAL – DAY CLG STPT + DAY HTG STPT
- When the controller is heating mode, the cooling switchover setpoint is as follows:  
Cooling switchover point is equal to RM STPT DIAL – DAY HTG STPT + DAY CLG STPT

## Heating/Cooling Switchover Using Standard/Absolute Mode (Analog Room Unit)

### Analog (Series 1000) or Digital Room Units (Firmware Revision 25 or earlier)

The difference between day heating and day cooling setpoint establishes the separation for heat/cool switchover points (deadband = DAY CLG STPT – DAY HTG STPT).

- When the controller is in cooling mode, the heating switchover setpoint is as follows:  
Heating switchover point is equal to RM STPT DIAL – 0.5 \* the deadband
- When the controller is in heating mode, the cooling switchover setpoint is as follows:  
Cooling switchover point is equal to RM STPT DIAL + 0.5 \* the deadband

## Heating/Cooling Switchover Using Warmer/Cooler Mode (Analog Room Unit)

### Analog Room Unit (Series 1000)

The RM STPT DIAL will display the current temperature setpoint based on a plus or minus position or increment entered by the user at the room unit.

The amount of offset that can be entered with the analog room unit is limited to a value of minus STPT SPAN to plus STPT SPAN.

- When the controller is in cooling mode, the heating switchover setpoint is as follows:  
Heating switchover point is equal to DAY CLG STPT, plus the amount of offset entered
- When the controller is in heating mode, the cooling switchover setpoint is as follows:  
Cooling switchover point is equal to DAY HTG STPT, plus the amount of offset entered

## Room Temperature, Room Temperature Offset and CTL TEMP

ROOM TEMP is the temperature that is being sensed by the room temperature sensor (RTS).

RMTMP OFFSET (or TEMP OFFSET) is a user-adjustable offset that will compensate for deviations between the value of ROOM TEMP and the actual room temperature.

CTL TEMP is the room temperature that is used for control purposes. In other words, the application is trying to maintain CTL TEMP at the control setpoint.

When CTL TEMP is not overridden, CTL TEMP and ROOM TEMP are related by the following equation:

$$\text{CTL TEMP} = \text{ROOM TEMP} + \text{RMTMP OFFSET (or TEMP OFFSET)}$$

If CTL TEMP is not overridden, then:

- The current value of ROOM TEMP (normal or overridden) is used to determine the value of CTL TEMP.
- If ROOM TEMP has a status of Failed, then last known good value of ROOM TEMP is used to determine the value of CTL TEMP.

If CTL TEMP is overridden then:

- CTL TEMP equals its overridden value and the points ROOM TEMP and TEMP (RMTMP) OFFSET have no effect on the value of CTL TEMP. Where  $\text{CTL TEMP} = \text{ROOM TEMP} + \text{RMTMP OFFSET}$ .

## Day and Night Modes

The day/night status of the space is determined by the status of DAY.NGT. The control of this point differs depending on whether the controller is monitoring the status of a wall switch or if the controller is connected to a field panel.

When a wall switch is physically connected to the termination strip on the controller at DI 2 (see the *Control Diagram* in the Overview section), and WALL SWITCH = YES, the controller monitors the status of DI 2. When the status of DI 2 is ON (the switch is closed), then DAY.NGT will be set to DAY indicating that the controller is in day mode. When the status is OFF (the switch is open), then DAY.NGT will be set to NIGHT indicating that the controller is in night mode.

When WALL SWITCH = NO, the controller does not monitor the status of the wall switch, even if one is connected to it. In this case, if the controller is operating stand-alone, then the controller stays in day mode all the time. If the controller is operating with centralized control (that is, it is connected to a field panel), then the field panel can send an operator or PPCL command to override the status of DAY.NGT.

## Night Mode Override Switch

If an override switch is present on the room temperature sensor and a value (in hours) other than zero has been entered into OVRD TIME, pressing the override switch will reset the controller to DAY operational mode for the time period that is set in OVRD TIME. The status of NGT OVRD changes to DAY. After the override time elapses, the controller returns to night mode and the status of NGT OVRD changes back to NIGHT.

The override switch on the room sensor will only affect the controller when it is in night mode.

## Ventilation Demand Minimum

Some VAV applications provide only two flow setpoints for minimum air flow control: minimum cooling and minimum heating (CLG FLOW MIN, HTG FLOW MIN). These setpoints are initially set during start-up and commissioning for each controller and include the zone ventilating requirements. In most cases, these minimum flow

setpoints (and the maximum flow setpoints) are specified by the design engineer or the owner and are confirmed by the balancer and/or commissioning agent.

This VAV application has the ability to adjust the minimum flow setpoint for varying ventilation needs during occupied times. This may be done internally on controllers with PPCL, or externally via IAQ or DCV programs in a field panel. As the requirement may also exist to keep the cooling and heating flow minimum setpoints as originally specified, a new setpoint, ventilation demand minimum (VENT DMD MIN), is provided (and can be changed or written to as necessary).

The additional flow setpoint (VENT DMD MIN) is provided to allow setting and adjustment of the ventilation air required during occupied modes. VENT DMD MIN flow setpoint is used in conjunction with the existing cooling and heating flow minimum setpoints but only during the occupied modes.

VENT DMD MIN can be set above, equal to, or below CLG FLOW MIN or HTG FLOW MIN setpoints and the controlling minimum would be the larger of the two. This allows the cooling flow min to be set to zero and use the vent demand to control cooling and heating ventilation requirements.

VENT DMD MIN can be controlled (reset) externally, or by PPCL in the controller, for ventilation demands as based on CO2 or other indoor air quality requirements. Minimum air flow will be the larger of cooling flow min or heating flow min setpoints and the current ventilation demand flow setpoint. The control maximum flow setpoints are not affected by VENT DMD MIN.

## Night Flow Minimum

Some applications do not provide a distinction between day/occupied and night/unoccupied modes for the minimum air flow setpoints. For day/occupied operation, the cooling or heating minimum flow setpoints were designed to be the air flow for minimum cooling and ventilation or for air flow across heating coils. At night/unoccupied times the associated air handling unit was typically not running and therefore no distinction was necessary.

## Modulating Damper During Heating Mode (Optional)



### ▲ CAUTION

The heating/cooling switchover mechanism is not affected by the air temperature in the supply duct.

To change the value of HEAT.COOL based on the supply air temperature, you must command HEAT.COOL through PPCL. This is required when the flow loop will be used as a source of cooling in cooling mode and a source of heat in heating mode (see Examples 1 through 3 in *Sequencing Logic*). If the flow loop is used in heating mode just to meet minimum air requirements, the heating/cooling switchover mechanism operates as described in this section to control HEAT.COOL (see Example 4 in *Sequencing Logic*).

## Control Loops

The controller is controlled by three Proportional, Integral, and Derivative (PID) control loops; two temperature loops and a flow loop.

The two temperature loops are a cooling loop and a heating loop. The active temperature loop maintains room temperature at the value in CTL STPT. See *Control Temperature Setpoints*.

**Heating Loop** – If the controller is in heating mode, the operation of the flow loop is flexible. It can be set up to do one of the following:

- Option 1: Constantly maintain airflow out of the terminal box equal to CTL FLOW MIN.
- Option 2: Operate in sequence with the reheat.
- Option 3: Operate parallel with the reheat.
- Option 4: Have its operation overlap with the operation of the electric reheat.

If the option 1 is chosen, HTG LOOPOUT will control the electric reheat in order to maintain the room temperature. If option 2, 3, or 4 is chosen, HTG LOOPOUT will control both the flow loop setpoint (FLOW STPT) and the electric reheat in order to maintain the room temperature. See Sequencing Logic [→ 19] for more information.

HTG LOOPOUT will adjust the value of FLOW STPT differently depending on which flow loop setup is chosen. However, the following rule applies no matter what setup is chosen.

In heating mode, FLOW STPT is never set below (CTL FLOW MIN/HTG FLOW MAX) × 100% flow or above 100% flow.

In heating mode, CTL FLOW MIN is equal to HTG FLOW MIN.

**Flow Loop** – The flow loop maintains FLOW STPT by modulating the supply air damper, DMPR COMD. The flow loop maintains the airflow between CTL FLOW MIN and CTL FLOW MAX.

#### DAY/OCCUPIED MODE

When the controller is in day cooling mode:

- CTL FLOW MIN = larger of CLG FLOW MIN and VENT DMD MIN, and CTL FLOW MAX = CLG FLOW MAX.

When the controller is in day heating mode:

- CTL FLOW MIN = larger of HTG FLOW MIN and VENT DMD MIN, and CTL FLOW MAX = HTG FLOW MAX.

#### NIGHT/UNOCCUPIED MODE

When the controller is in night cooling mode:

- CTL FLOW MIN = NGT FLOW MIN, and CTL FLOW MAX = CLG FLOW MAX.

When the controller is in night heating mode:

- CTL FLOW MIN = NGT FLOW MIN, and CTL FLOW MAX = HTG FLOW MAX.

To enhance stable flow control, an advanced algorithm is used to calculate a controllable setpoint as the value approaches zero cfm (lps).

When the controller is in cooling mode, CTL FLOW MIN = CLG FLOW MIN, and CTL FLOW MAX = CLG FLOW MAX.

When the controller is in heating mode, CTL FLOW MIN = HTG FLOW MIN, and CTL FLOW MAX = HTG FLOW MAX.

## Staged Heating Coil - Terminal Unit



**⚠ CAUTION**

Verify that the equipment is supplied with safeties by others.  
 Ensure there is airflow across the heating coils when they are to be energized.

The heating loop controls up to three stages of electric reheat to warm up the room. The electric reheat is time modulated using a duty cycle as shown in the Table *Staged Heating*.

When the heating coil is located in the terminal unit, supply airflow is required to allow heat transfer from the coil to the room. EHEAT FLOW provides a means to ensure that there is sufficient airflow present before activating any heating stage.

If the flow setpoints for HTG MIN FLOW and HTG MAX FLOW results in a flow that is less than as set in EHEAT FLOW, the electric stages of heat will not be energized regardless of the heating demand. (for example, If HTG MAX FLOW is 1000 cfm and HTG MIN FLOW is 200 cfm, setting EHEAT FLOW to any percentage less than 20% will prevent activation of any heating stage.)

When the controller is in cooling mode, the electric heat is OFF at all times.

### Example

When energized, the heating coils will respond to the heating demand based on the configuration and duty cycle time.

If the duty cycle is 10 minutes (STAGE TIME = 10 minutes), and the heating loop is calling for 60% of heating (HTG LOOPOUT = 60%) for every 10-minute period, the stages of electric auxiliary heat cycle are as follows:

Staged Heating						
	Stage 1: minutes		Stage 2: minutes		Stage 3: minutes	
	ON	OFF	ON	OFF	ON	OFF
With 1 stage of electric heat	6	4	-	-	-	-
With 2 stages of electric heat	10	0	2	8	-	-
With 3 stages of electric heat	10	0	8	2	0	10

### AVERAGE HEAT OUT

When the controller is in heating mode, AVG HEAT OUT indicates the percentage of the heating loop that is used for control and cycles the heating stages, independent of the number of stages enabled. The selected range for the heating stages (REHEAT START and REHEAT END) is applied to the HTG LOOPOUT to determine the AVG HEAT OUT.

For example, if REHEAT START = 0, and REHEAT END = 50%, then:

When HTG LOOPOUT = 0%, AVG HEAT OUT = 0%;

HTG LOOPOUT = 25%, AVG HEAT OUT = 50%

HTG LOOPOUT = 50% (or higher), AVG HEAT OUT = 100%

## Staged Heating Coil - Baseboard Radiation

The application can be set up to control a 2-position heating coil or a stage of electric heat that is located outside of the air terminal unit. The staged heat is time modulated using a duty cycle as shown in the following example.

When the heating coil is external to the terminal unit (for example, baseboard radiation, perimeter heating coil or stage), airflow from the terminal unit is not required for the heat transfer to the room.

In this configuration, the setpoint for HTG FLOW MIN can be set (per job specification) for the required ventilation air. To prevent excessive cold air during heating, the maximum heating flow should also be set to this value (for example, HTG FLOW MAX = HTG FLOW MIN).

To insure that the external heating can be activated by heating demand and not dependent on airflow, set the flow interlock, EHEAT FLOW, to a percentage value less than the HTG FLOW MIN (for example, if HTG FLOW MIN = 200 and HTG FLOW MAX = 1000, set EHEAT FLOW to a percentage less than 20%, such as 15%, or, to allow it to operate with minimum interlock, set = 0 %).

If the controller is in cooling mode, the heating stages will be off.

## Sequencing Logic



### NOTE:

Setting FLOW START = 0 and FLOW END = 100, will provide modulating supply airflow during heating mode (HTG FLOW MIN to HTG FLOW MAX).

In heating mode, this application includes logic that allows the flow loop to operate in sequence, parallel, or overlapping with the heating device. Selected portions of the output of the heating loop, HTG LOOPOUT, will drive both the flow loop and the heating from 0 to 100%. See the *Examples* section.

### Example 1 (Airflow Sequenced First)

Assume that your system has electric heat that is to operate in sequence with the flow loop. If:

- FLOW START = 0%
- FLOW END = 50%
- REHEAT START = 50%
- REHEAT END = 100%

then,

- When HTG LOOPOUT = 0%, FLOW STPT will equal 0% flow.
- When HTG LOOPOUT = 25%, FLOW STPT will equal 50% flow.
- When HTG LOOPOUT ≥ 50%, FLOW STPT will equal 100% flow.
- When HTG LOOPOUT ≤ 50%, the electric heat will be off all the time.
- When HTG LOOPOUT = 75%, for every 10-minute period the electric heat will be on for 5 minutes and off for 5 minutes.
- When HTG LOOPOUT = 100%, the electric heat will be on all the time.

### Example 2 (Airflow and Heat Sequenced Together)

Assume that your system has electric heat that is to operate in parallel with the flow loop. If:

- FLOW START = 0%

- FLOW END = 100%
- REHEAT START = 0%
- REHEAT END = 100%

then,

- When HTG LOOPOUT = 0%, FLOW STPT will equal 0% flow.
- When HTG LOOPOUT = 50%, FLOW STPT will equal 50% flow.
- When HTG LOOPOUT = 100%, FLOW STPT will equal 100% flow.
- When HTG LOOPOUT = 0%, the electric heat will be off all the time.
- When HTG LOOPOUT = 50%, for every 10-minute period the electric heat will be on for 5 minutes and off for 5 minutes.
- When HTG LOOPOUT = 100%, the electric heat will be on all the time.

### Example 3 (Airflow Sequenced First with Overlap for Heating)

Assume that your system has electric heat that is to operate overlapping with the flow loop. If:

- FLOW START = 0%
- FLOW END = 75%
- REHEAT START = 25%
- REHEAT END = 100%

then,

- When HTG LOOPOUT = 0%, FLOW STPT will equal 0% flow.
- When HTG LOOPOUT = 37.5%, FLOW STPT will equal 50% flow.
- When HTG LOOPOUT  $\geq$  75%, FLOW STPT will equal 100% flow.
- When HTG LOOPOUT  $\leq$  25%, the electric heat will be off all the time.
- When HTG LOOPOUT = 62.5%, for every 10-minute period the electric heat will be on for 5 minutes and off for 5 minutes.
- When HTG LOOPOUT = 100%, the electric heat will be on all the time.

Another option that the sequencing logic provides is to have the flow loop provide an airflow equal to HTG FLOW MIN throughout the heating mode with all of the temperature control being done by the electric heat. The airflow minimum will be maintained by setting the FLOW START and FLOW END to a value of 0%, resulting in the corresponding minimum flow throughout the entire heating mode, regardless of the value of HTG LOOPOUT. Example 4 clarifies this:

### Example 4 (Airflow Remains Fixed; Heating Modulates)

If the job requirement specifies that the supply airflow in heating will remain fixed, set HTG FLOW MIN = HTG FLOW MAX so that the fixed value in heating is indicated. An alternative setting, would be to set FLOW START = FLOW MIN = 0, which would fix the flow at HTG FLOW MIN.

Assume that your system has electric heat that provides the temperature control in the heating mode, while the flow loop provides for the minimum air requirements.

- HTG FLOW MIN = 170 cfm
- HTG FLOW MAX = 1000 cfm
- STAGE COUNT = 1
- STAGE TIME = 10 minutes

If:

- FLOW START=0%
- FLOW END=0% (or/and HTG FLOW MIN = HTG FLOW MAX)

- REHEAT START = 0%
  - REHEAT END = 100%
- then,
- When HTG LOOPOUT = 0%, FLOW STPT will equal  $(170 \text{ cfm}/1000 \text{ cfm}) \times 100\%$  flow = 17% flow. This will cause the flow loop to maintain an airflow of 170 cfm out of the terminal box.
  - When HTG LOOPOUT = 50%, FLOW STPT will equal 17% flow.
  - When HTG LOOPOUT = 100%, FLOW STPT will equal 17% flow.
  - When HTG LOOPOUT = 0%, the electric heat will be off all the time.
  - When HTG LOOPOUT = 50%, for every 10-minute period the electric heat will be on for 5 minutes and off for 5 minutes.
  - When HTG LOOPOUT = 100%, the electric heat will be on all the time.

## Electric Heat Interlock

### Terminal unit heat stages:

The electric heat stages will be enabled as long as  $\text{FLOW} > \text{EHEAT FLOW}$ . The electric heat stages will not be disabled (turned OFF) until  $\text{FLOW} < \text{EHEAT FLOW} - 5\%$ . Once disabled, FLOW must become greater than EHEAT FLOW before the electric heat stages will return to normal control.

	<b>⚠ CAUTION</b>
	Do not set EHEAT FLOW to less than 5%; otherwise, the electric heat interlock will be disabled.

### Baseboard heat stage(s):

The electric or 2-position valve heat stages that are located outside the terminal unit do not require supply airflow. When there is only baseboard heating coils, the supply airflow interlock can be effectively disabled ( $\text{EHEAT FLOW} = 0$ ).

## Calibration

Calibration of the controller's internal air velocity sensor(s) is periodically required to maintain accurate air velocity readings. CAL SETUP is set with the desired calibration option during controller startup.

Depending on the value of CAL SETUP, calibration may be set to take place automatically or manually. If CAL AIR = YES, calibration is in progress.

- For a controller used without an Autozero Module (CAL MODULE, = NO), the damper is commanded closed to get a zero airflow reading during calibration.
- For a controller used with an Autozero Module (CAL MODULE = YES), calibration occurs without closing the damper.

	<b>⚠ CAUTION</b>
	On long board controllers, the Autozero Module is connected to DO 8.

At the end of a calibration sequence, CAL AIR automatically returns to NO. A status of NO indicates that the controller is not in a calibration sequence.

The Autozero Module is enabled when it is wired to DO 8 and CAL MODULE is set to YES.

### **Floating Control Actuation Auto-correct**

In addition to the existing options for floating control actuator full stroke actions, all floating control actuators are provided with additional logic to fully drive open or closed when commanded to 100% or 0%.

## **Room Unit Operation**

### **Sensor Select**

SENSOR SEL is a configurable, enumerated point (values are additive). This point tells the controller what type of room unit is being used and how to handle loss of data. It also provides the ability to enable the optional RH and CO2 sensors and which thermistor type is connected.

### **Room Temperature, Setpoint, RH and CO2**

- When the digital room unit (Series 2200/2300) is used, SENSOR SEL selects the source for temperature and setpoint and enables a loss of communications indication:
  - Temperature/Setpoint enable and supervision for fail communications (temperature) with a value of 1.
  - Relative humidity enable and supervision for fail communications with a value of 2.
  - CO2 enable and supervision for fail communications with a value of 4.
- When the analog room unit (Series 1000/2000) is used, default temperature sensing (0) from an analog room unit is enabled (relative humidity and CO2 sensing are not available and should not be selected).

### **Thermistor Inputs**

- Default for either input is 10K.
- To enable 100K thermistor on input, see the following table for additive values of 8 or 16.

## Other Inputs (only available on Digital Room Unit)

- Use the following table to select and enable communications supervision of room temperature/setpoint dial, relative humidity and CO<sub>2</sub> for additive values of 1, 2 and 4.

SENSOR SEL Value * (additive)	Description (include values to enable feature)
1	Select Digital Room Unit (for temperature sensing and setpoint dial)
2	Relative Humidity (RH) sensing
4	CO <sub>2</sub> sensing
8	If short board: 100K $\Omega$ thermistor on AI 3 (else input is 10K $\Omega$ ) If long board: 100K $\Omega$ thermistor on AI 5 (else input is 10K $\Omega$ )
16	Long board only: 100K $\Omega$ thermistor on AI 4 (else input is 10K $\Omega$ )

## Room CO<sub>2</sub>

RM CO<sub>2</sub> displays the CO<sub>2</sub> value in units of parts-per-million (PPM). RM CO<sub>2</sub> (from the digital 2200/2300 room units) can be used with PPCL in the PTEC/A TEC controller or unbundled for control or monitoring purposes.

## Room RH

RM RH displays the relative humidity value in percent. RM RH can be used for PPCL in the PTEC or unbundled for control or monitoring purposes.

RM RH displays the relative humidity value in percent.

## Room DEW POINT

The controller provides a calculation for DEW POINT temperature in Fahrenheit degrees (or Celsius degrees) using room temperature (using CLT TEMP) and room humidity (using RM RH). This calculation is valid for ranges of 55°F (12.8°C) to 95°F (35°C) and 20 to 100% relative humidity.

## Auto Discovery

Auto Discovery allows you to automatically discover and identify PTEC/A TEC controllers on the BACnet MS/TP Network. There are two basic configurations:

- Devices not configured with an address. (Devices are discovered by their unique serial number.)
- Devices configured with an address and available for modification.

## Auto Addressing

Auto Addressing allows you to automatically assign device addresses to a PTEC controller on the BACnet MS/TP Network. If a controller is not configured with a MAC address, you have the option to auto-address or manually address the controller. During this time the baud rate is automatically detected by the controller.

Controller(s) must be connected on the BACnet/IP network in order for automatic addressing to occur.

## PPCL STATUS

PPCL STATUS displays LOADED or EMPTY.

- LOADED = PPCL programming is present in the controller. A new application number must be assigned (12000 through 12999).
- EMPTY = NO PPCL programming is present.

The maximum number of PPCL dynamic points is 15.

## Fail Mode Operation

If the air velocity sensor fails, the controller uses pressure dependent control. The temperature loop controls the operation of the damper.

If the room temperature sensor fails, the controller operates using the last known temperature value.

## Application Notes

- If temperature swings in the room are excessive or there is trouble maintaining the setpoint, the cooling loop needs to be tuned. If FLOW is oscillating while FLOW STPT is constant, the flow loop requires tuning.
- The controller, as shipped from the factory, keeps all associated equipment OFF. See the appropriate *Start-up Procedures* for information on how to release the controller and its equipment to application control.

## Wiring Diagram



---

**NOTE:**

The controller's DOs control 24 Vac loads only. The maximum rating is 12 VA for each DO. An external interposing relay is required for any of the following:

- VA requirements higher than the maximum
  - 110 or 220 Vac requirements
  - DC power requirements
  - Separate transformers used to power the load  
(for example part number 540-147, Terminal Equipment Controller Relay Module)
- 



---

**NOTE:**

Thermistor inputs are 10K (default) or 100K software selectable (AUX TEMP AI X).

---

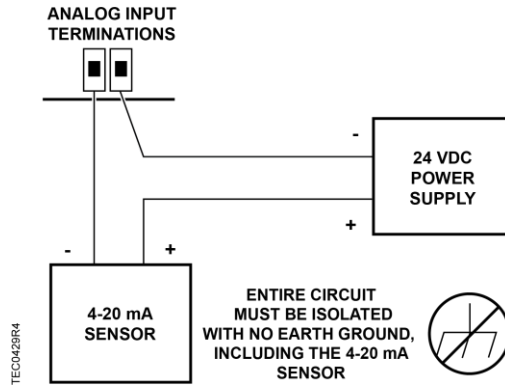

TEC042BR4  
Wiring for AI with a 4 to 20 mA Sensor.



**CAUTION**

Each 4-20 mA sensor requires a SEPARATE dedicated power limited 24 VDC power supply.  
DO NOT use the same transformer to power both the sensor and the controller.



**NOTE:**

If the voltage/current switch is set to current and a 4 to 20 mA sensor is connected to an AI, then special wiring requirements must be followed.

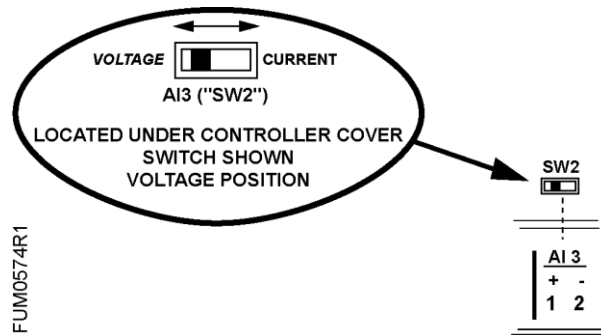

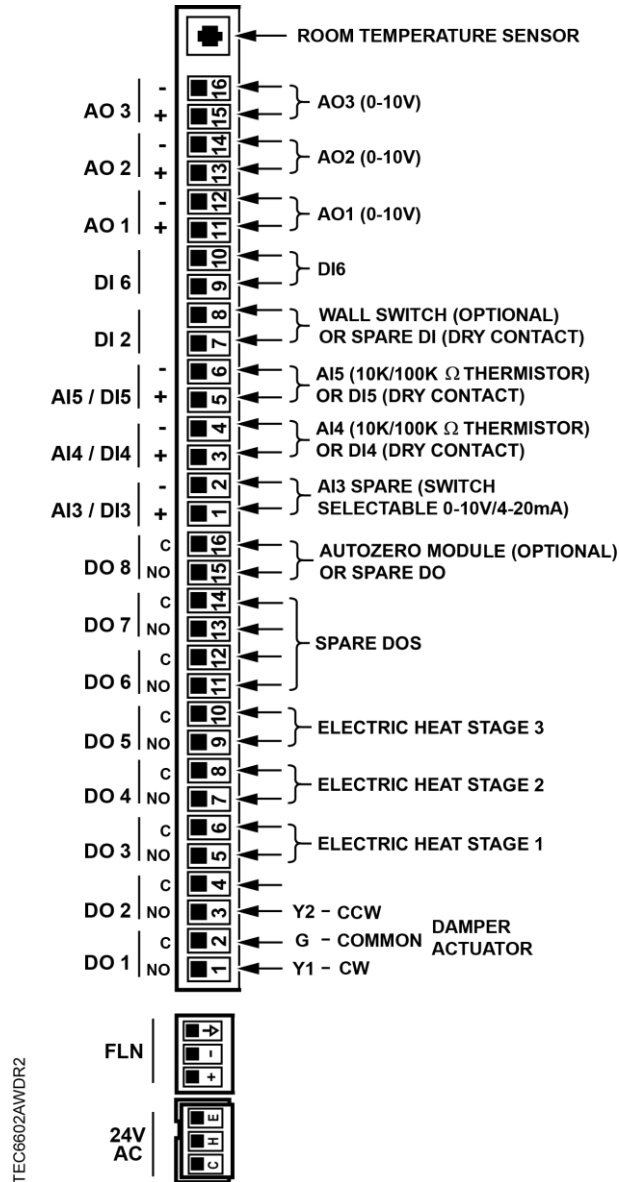

Application 6602 – Variable Air Volume with 3-Stage Electric Heat.

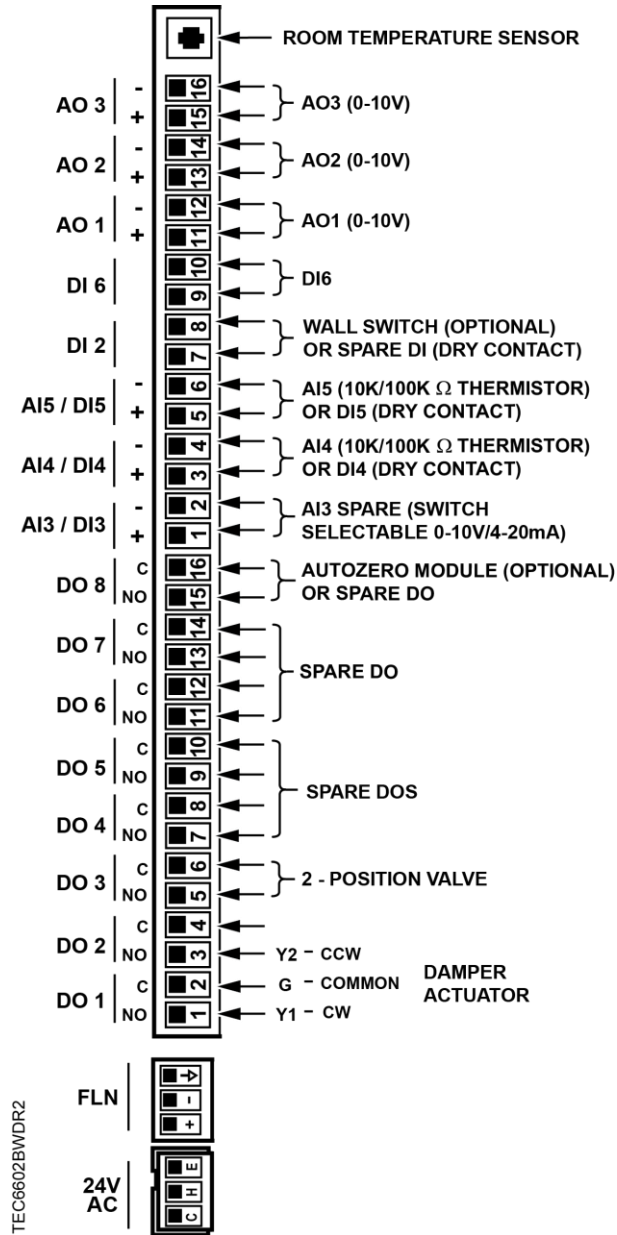

Application 6602 – Variable Air Volume with Baseboard Radiation.

## Application 6602 Point Database

Object Type <sup>1</sup>	Object Instance (Point Number)	Object Name (Descriptor)	Factory Default (SI Units) <sup>2</sup>	Eng Units (SI Units)	Range	Active Text	Inactive Text
AO	1	CTLR ADDRESS	255	--	0-255	--	--
AO	2	APPLICATION	6687	--	0-32767	--	--
AO	3	RMTMP OFFSET	0.0 (0.0)	DEG F (DEG C)	-31.75-32	--	--
AI	{04}	ROOM TEMP	74.0 (23.44888)	DEG F (DEG C)	48-111.75	--	--
BO	{05}	HEAT.COOL	COOL	--	Binary	HEAT	COOL
AO	6	DAY CLG STPT	74.0 (23.44888)	DEG F (DEG C)	48-111.75	--	--
AO	7	DAY HTG STPT	70.0 (21.20888)	DEG F (DEG C)	48-111.75	--	--
AO	8	NGT CLG STPT	82.0 (27.92888)	DEG F (DEG C)	48-111.75	--	--
AO	9	NGT HTG STPT	65.0 (18.40888)	DEG F (DEG C)	48-111.75	--	--
BI	{10}	DI 6	OFF	--	Binary	ON	OFF
AO	11	RM STPT MIN	55.0 (12.80888)	DEG F (DEG C)	48-111.75	--	--
AO	12	RM STPT MAX	90.0 (32.40888)	DEG F (DEG C)	48-111.75	--	--
AI	{13}	RM STPT DIAL	74.0 (23.44888)	DEG F (DEG C)	48-111.75	--	--
BO	14	STPT DIAL	NO	--	Binary	YES	NO
AI	{15}	AUX TEMP AI5	74.0 (23.495556)	DEG F (DEG C)	37.5-165	--	--
AO	16	FLOW START	0	PCT	0-102	--	--
AO	17	FLOW END	0	PCT	0-102	--	--
BO	18	WALL SWITCH	NO	--	Binary	YES	NO
BI	{19}	DI OVRD SW	OFF	--	Binary	ON	OFF
AO	20	OVRD TIME	0	HRS	0-255	--	--
BO	{21}	NGT OVRD	NIGHT	--	Binary	NIGHT	DAY
AO	22	REHEAT START	0	PCT	0-102	--	--
AO	23	REHEAT END	100	PCT	0-102	--	--
BI	{24}	DI 2	OFF	--	Binary	ON	OFF
BI	{25}	DI 5	OFF	--	Binary	ON	OFF
BO	{29}	DAY.NGT	DAY	--	Binary	NIGHT	DAY
AO	31	CLG FLOW MIN	220	CFM ( LPS)	0-131068	--	--

Object Type <sup>1</sup>	Object Instance (Point Number)	Object Name (Descriptor)	Factory Default (SI Units) <sup>2</sup>	Eng Units (SI Units)	Range	Active Text	Inactive Text
			(103.818)				
AO	32	CLG FLOW MAX	2200 (1038.18)	CFM ( LPS)	0-131068	--	--
AO	33	HTG FLOW MIN	220 (103.818)	CFM ( LPS)	0-131068	--	--
AO	34	HTG FLOW MAX	2200 (1038.18)	CFM ( LPS)	0-131068	--	--
AI	{35}	AIR VOLUME	0 (0.0)	CFM ( LPS)	0-131068	--	--
AO	36	FLOW COEFF	1	--	0-2.55	--	--
AO	{37}	MTR3 COMD	0	PCT	0-102	--	--
AO	{38}	MTR3 POS	0	PCT	0-102	--	--
AO	39	MTR3 TIMING	130	SEC	0-511	--	--
BI	{40}	DI 4	OFF	--	Binary	ON	OFF
BO	{41}	DO 1	OFF	--	Binary	ON	OFF
BO	{42}	DO 2	OFF	--	Binary	ON	OFF
BO	{43}	HEAT STAGE 1	OFF	--	Binary	ON	OFF
BO	{44}	HEAT STAGE 2	OFF	--	Binary	ON	OFF
BO	{45}	HEAT STAGE 3	OFF	--	Binary	ON	OFF
BO	{46}	DO 6	OFF	--	Binary	ON	OFF
BI	{47}	DI 3	OFF	--	Binary	ON	OFF
AO	{48}	DMPR COMD	0	PCT	0-102	--	--
AO	{49}	DMPR POS	0	PCT	0-102	--	--
AI	{50}	AI 4	74.0 (23.495556)	DEG F (DEG C)	37.5-165	--	--
AO	51	MTR1 TIMING	95	SEC	0-511	--	--
AI	{54}	AI3	0	PCT	0-102	--	--
AO	56	DMPR ROT ANG	90	--	0-255	--	--
AO	58	MTR SETUP	0	--	0-255	--	--
AO	59	DO DIR. REV	0	--	0-255	--	--
AO	60	EHEAT FLOW	20	PCT	0-102	--	--
AO	63	CLG P GAIN	20.0 (36.0)	--	0-63.75	--	--
AO	64	CLG I GAIN	0.01 (0.018)	--	0-1.023	--	--
AO	65	CLG D GAIN	0 (0.0)	--	0-510	--	--
AO	{66}	AOV 1	0	VOLTS	0-10.23	--	--
AO	67	HTG P GAIN	10.0 (18.0)	--	0-63.75	--	--
AO	68	HTG I GAIN	0.01 (0.018)	--	0-1.023	--	--
AO	69	HTG D GAIN	0 (0.0)	--	0-510	--	--

Object Type <sup>1</sup>	Object Instance (Point Number)	Object Name (Descriptor)	Factory Default (SI Units) <sup>2</sup>	Eng Units (SI Units)	Range	Active Text	Inactive Text
AO	{70}	AOV 2	0	VOLTS	0-10.23	--	--
AO	71	FLOW P GAIN	0	--	0-51.15	--	--
AO	72	FLOW I GAIN	0.01	--	0-1.023	--	--
AO	73	FLOW D GAIN	0	--	0-510	--	--
AO	74	FLOW BIAS	50	PCT	0-102	--	--
AO	{75}	FLOW	0	PCT	0-1023.75	--	--
AO	{76}	CTL FLOW MIN	220 (103.818)	CFM ( LPS)	0-131068	--	--
AO	{77}	CTL FLOW MAX	2200 (1038.18)	CFM ( LPS)	0-131068	--	--
AO	{78}	CTL TEMP	74.0 (23.44888)	DEG F (DEG C)	48-111.75	--	--
AO	{79}	CLG LOOPOUT	0	PCT	0-102	--	--
AO	{80}	HTG LOOPOUT	0	PCT	0-102	--	--
AO	{81}	AVG HEAT OUT	0	PCT	0-409.2	--	--
AO	82	STAGE MAX	90	PCT	0-102	--	--
AO	83	STAGE MIN	10	PCT	0-102	--	--
AO	85	SWITCH LIMIT	5.2	PCT	0-102	--	--
AO	86	SWITCH TIME	10	MIN	0-255	--	--
BO	87	CAL MODULE	NO	--	Binary	YES	NO
AO	88	STAGE COUNT	1	--	0-255	--	--
AO	89	STAGE TIME	10	MIN	0-255	--	--
AO	90	SWITCH DBAND	1.0 (0.56)	DEG F (DEG C)	0-63.75	--	--
AO	{91}	AOV 3	0	VOLTS	0-10.23	--	--
AO	{92}	CTL STPT	74.0 (23.44888)	DEG F (DEG C)	48-111.75	--	--
AO	{93}	FLOW STPT	0	PCT	0-255.75	--	--
BO	{94}	CAL AIR	NO	--	Binary	YES	NO
AO	95	CAL SETUP	4	--	0-255	--	--
AO	96	CAL TIMER	12	HRS	0-255	--	--
AO	97	DUCT AREA	1.0 (0.09292)	SQ. FT (SQ M)	0-6.375	--	--
AO	98	LOOP TIME	5	SEC	0-255	--	--
AO	{99}	ERROR STATUS	0	--	0-255	--	--
BO	{102}	DO 7	OFF	--	Binary	ON	OFF
BO	{103}	DO 8	OFF	--	Binary	ON	OFF
AO	104	NGT FLOW MIN	0 (0.0)	CFM ( LPS)	0-131068	--	--

Object Type <sup>1</sup>	Object Instance (Point Number)	Object Name (Descriptor)	Factory Default (SI Units) <sup>2</sup>	Eng Units (SI Units)	Range	Active Text	Inactive Text
AO	{105}	VENT DMD MIN	220 (103.818)	CFM ( LPS)	0-131068	--	--
AO	106	STPT SPAN	0.0 (0.0)	DEG F (DEG C)	0-63.75	--	--
AI	{121}	DEW POINT	0	DEG F (DEG C)	48-111.75	--	--
AO	124	SENSOR SEL	0	--	0-255	--	--
AI	{125}	RM CO2	1000	PPM	0-8191	--	--
AI	{126}	RM RH	50	PCT	0-102	--	--
BO	{127}	PPCL STATE	EMPTY	--	Binary	LOADED	EMPTY

- 1) Object Types are; Analog Input (AI), Analog Output (AO), Binary Input (BI) and Binary Output (BO).
- 2) A single value in a column means that the value is the same in English units and in SI units.
- 3) Point numbers that appear in brackets { } may be unbundled at the field panel.

Issued by  
Siemens Industry, Inc.  
Building Technologies Division  
1000 Deerfield Pkwy  
Buffalo Grove IL 60089  
Tel. +1 847-215-1000

© 2014 Siemens Industry, Inc.  
Technical specifications and availability subject to change without notice.