

Desigo™ PX

## Extension module

## PXX-PBUS

Integration of existing PT-I/O modules in Desigo  
Used with PXC50...D, PXC100...D or PXC200...D

The PXX-PBUS extension module allows for integrating existing PT-I/O modules in Desigo.

The PXX-PBUS extension module, when combined with a PXC50...D / PXC100...D / PXC200...D automation station and TXS1.12F10 supply module, replaces the UNIGYR and VISONIK process units as well as the PXC64-U, PXC128-U automation stations.

- PT-I/O modules can continue to be used.
- Existing periphery can be assumed without a change.
- Control panel wiring can be assumed and need only be supplemented by new supply modules.

See installation manual PT modules, M8102.

### Type summary

Type	Stock number	Name
PXX-PBUS	S55842-Z107	Extension module

### Equipment combinations

Types	Description	Data sheet
PXC50.D, PXC100.D, PXC200.D	Automation station (BACnet/LonTalk)	CM1N9222
PXC50-E.D, PXC100-E.D, PXC200-E.D	Automation station (BACnet/Ethernet)	CM1N9222
TXS1.12F10	Power supply module (TX-I/O)	CM2N8183
PXA-H1	Cover (option for PXM10, PXM20, PXM20-E)	--

## Function

Existing module carriers with PT-I/O modules can be connected to the PXX-PBUS extension module. All PT-I/O-Module are supported: PTM1... , PTM6.1PSI20-M, PTK1.23V02, PTK1.30V01, PTM50... , PTM52... , PTE-ASED.20, PTE-SED2 (see also PX Hardware overview N9202).

The device serves as P-bus interface for modular automation stations PXC50...D, PXC100...D or PXC200...D in Desigo.

The PT-I/O modules must now be supplied via the TXS1.12F10 supply module. In current installations, module supply was integrated in the UNIGYR/VISONIK process units or the PXC64-U / PXC128-U automation stations.

One TXS1.12F10 supply module is needed for each PBUS strand (at max. 64 load units each).

A separate transformer must be used to supply remote PT-I/O modules.

To connect to the PT-I/O modules, the device contains:

- One 4-pole plug with screw terminals for the P-bus (above).
- One 4-pole plug with screw terminals for the P-bus 2 (below).

## Hardware

Hardware consists of

- a system controller PXC50...D / 100...D / 200...D
- and an extension module PXX-PBUS.

## Topology

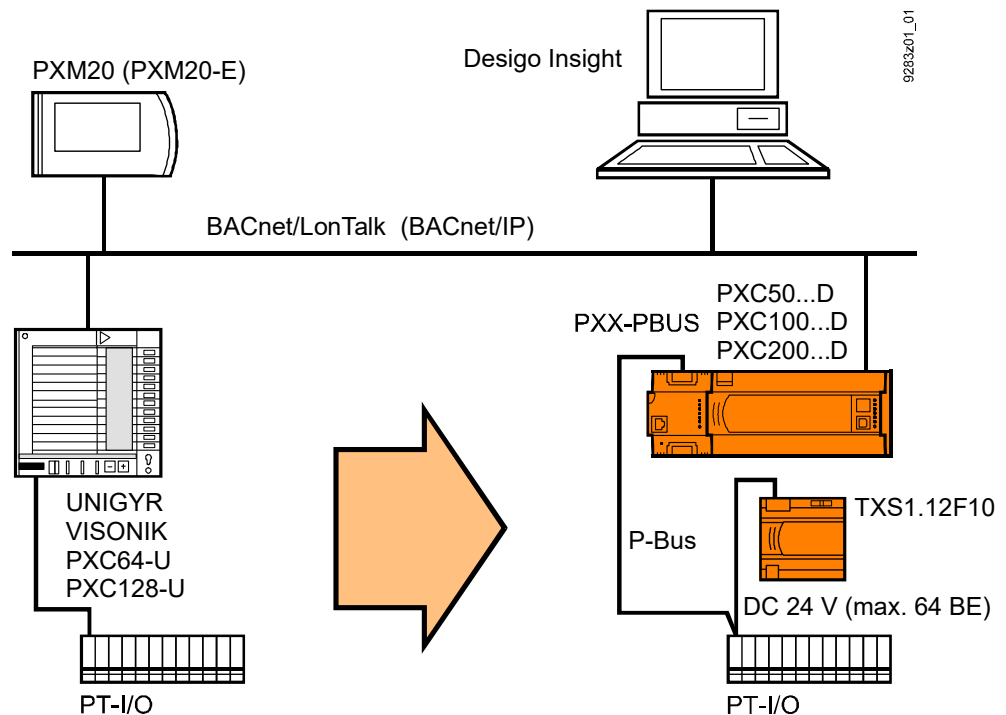

## Mechanical design

The compact build allows for mounting the extension modules in very narrow spaces.

### Housing

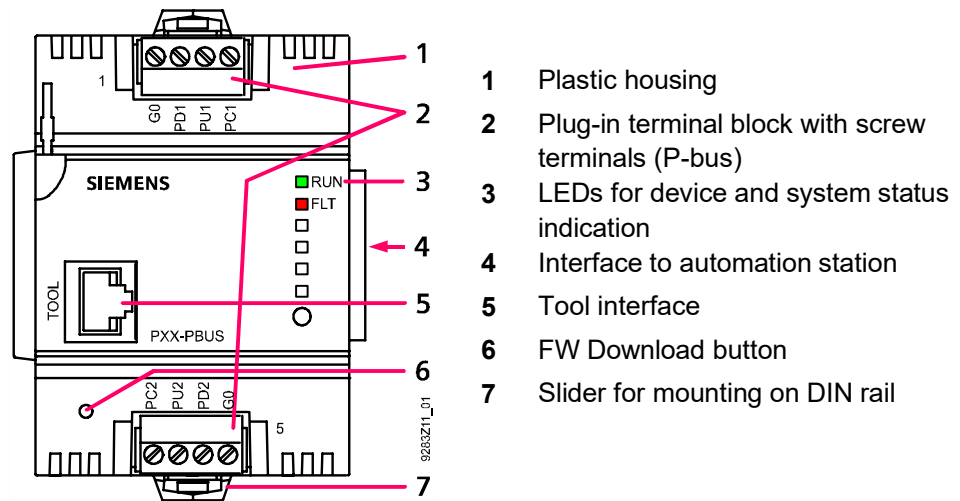

### LED display, buttons

LED	Color	Activity	Meaning / → Corrective action
RUN	Green	Continuously off	No power supply. → Check power supply.
		Continuously on	Power supply ok; firmware functions ok.
FLT	Red	Continuously off	Everything ok.
		Continuously on	Hardware fault detected during self-test. → PXX-PBUS module must be replaced.
		Fast flashing	No valid firmware present. → Reload firmware.
○		FW Download	Press using pointy object.

### Disposal



The devices are considered electronics devices for disposal in terms of European Directive 2012/19/EU (WEEE) and may not be disposed of as domestic waste. Dispose of the devices via the proper channels. Follow all local and currently applicable laws and regulations.

### Mounting

The extension module PXX-PBUS can be snapped onto standard DIN rails.

To connect, push the extension module from left to the PXC50...D / PXC100...D / PXC200...D automation station until the interfaces establish a connection.

**Note** You can insert cover frame PXA-H1 in the control panel front to cover the opening rather than a PXC64-U / PXC128-U automation station. It can be used as a carrier for the PXM10/20, PXM20-E operator unit.

Use cases

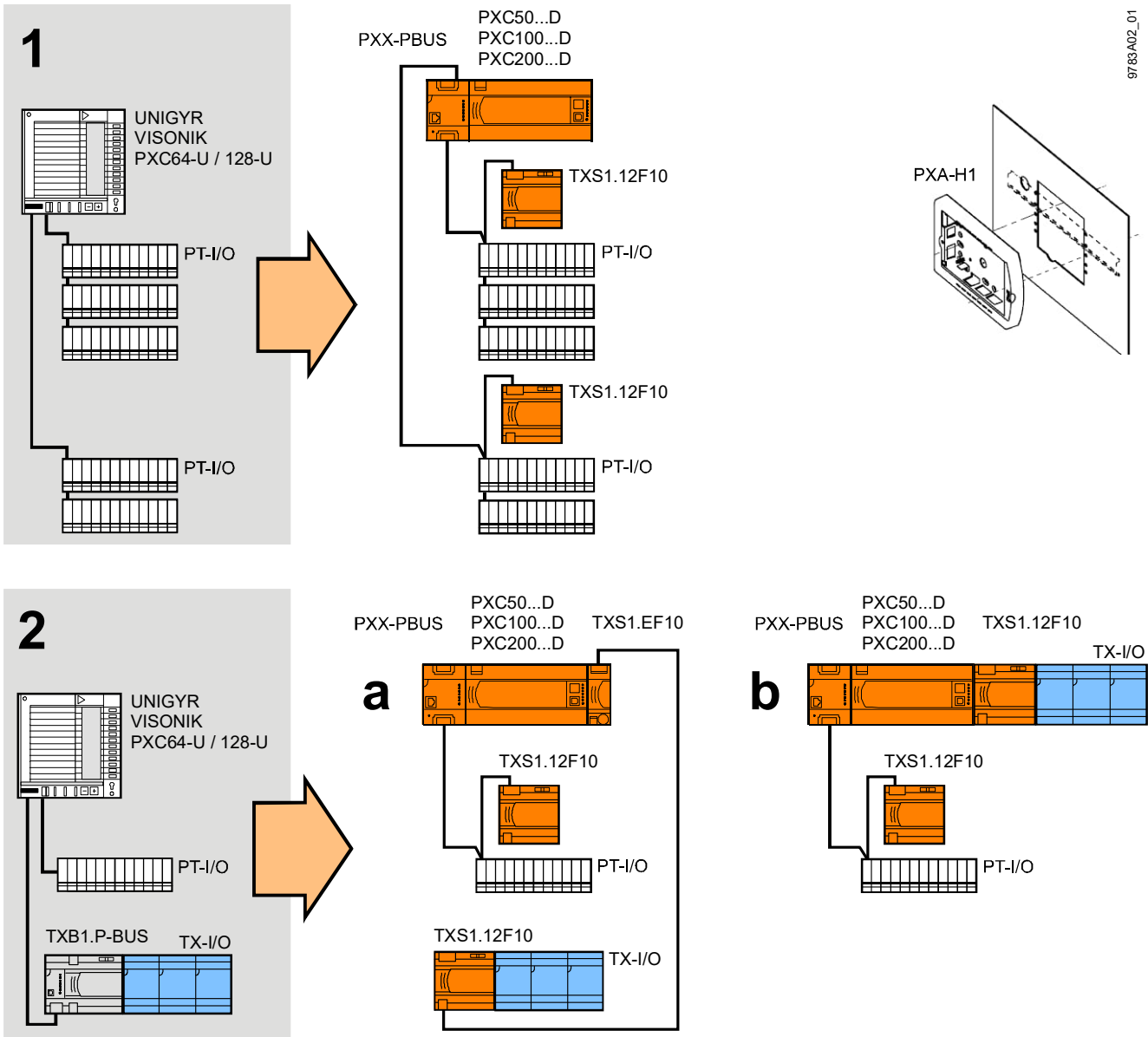

Additional elements

The following additional elements are needed to migrate from a UNIGYR/VISONIK process unit (or from a PXC64-U / PXC128-U automation station) to a PXC....D automation station:

- Supply module TXS1.12F10 as bus supply for the P-bus for each P-bus strand. Max. 64 load units can be supplied (1 LU = 12.5 mA, DC 24 V) \*)
- Existing TX-I/O modules also require a separate supply module TXS1.12F10, as the P-bus-BIM TXB1.P-BUS and its supply function can no longer be used. \*)
- The existing P-bus cabling must be extended by one additional line for G0 (1.5 mm<sup>2</sup> diameter).
- A PXA-H1 frame can be inserted in the control panel door to cover the opening rather than a PXC...-U automation station. It can be used as a carrier for the PXM10, PXM20, PXM20-E operator unit.

**STOP** Note!

\*) The admissibility of the number of load units is checked in the XWP.

**Limits of the PXX-PBUS extension module:**

- DB (Function blocks instances): 1500
- Trends: 100
- Local BACnet references. 100

**To prevent high cycle times of the PXX-PBUS extension module:**

- Only use PXC100-(E).D controllers together with PXX-PBUS; do not use PXC 200 controllers.
- Do not connect PXX-L11 or PXX-L12 or PX Web-modules (WO-W2) together with PXX-PBUS on the same controller.
- Do not use WebServer functionality on PXC, when using PXX-PBUS.
- Do not extend existing applications from PXC128-U or PXC64-U with new functionality.

# Installation

**Binding documentation** The electrical diagram for the specific project is binding for executing the given panel wiring.

**Basic implementation** The diagram below illustrates the wiring for power and bus line based on an example.

**Note** The AC 230 V wiring is not described in detail.

## Wiring example for automation station PXC50...D / PXC100 ....D / 200....D

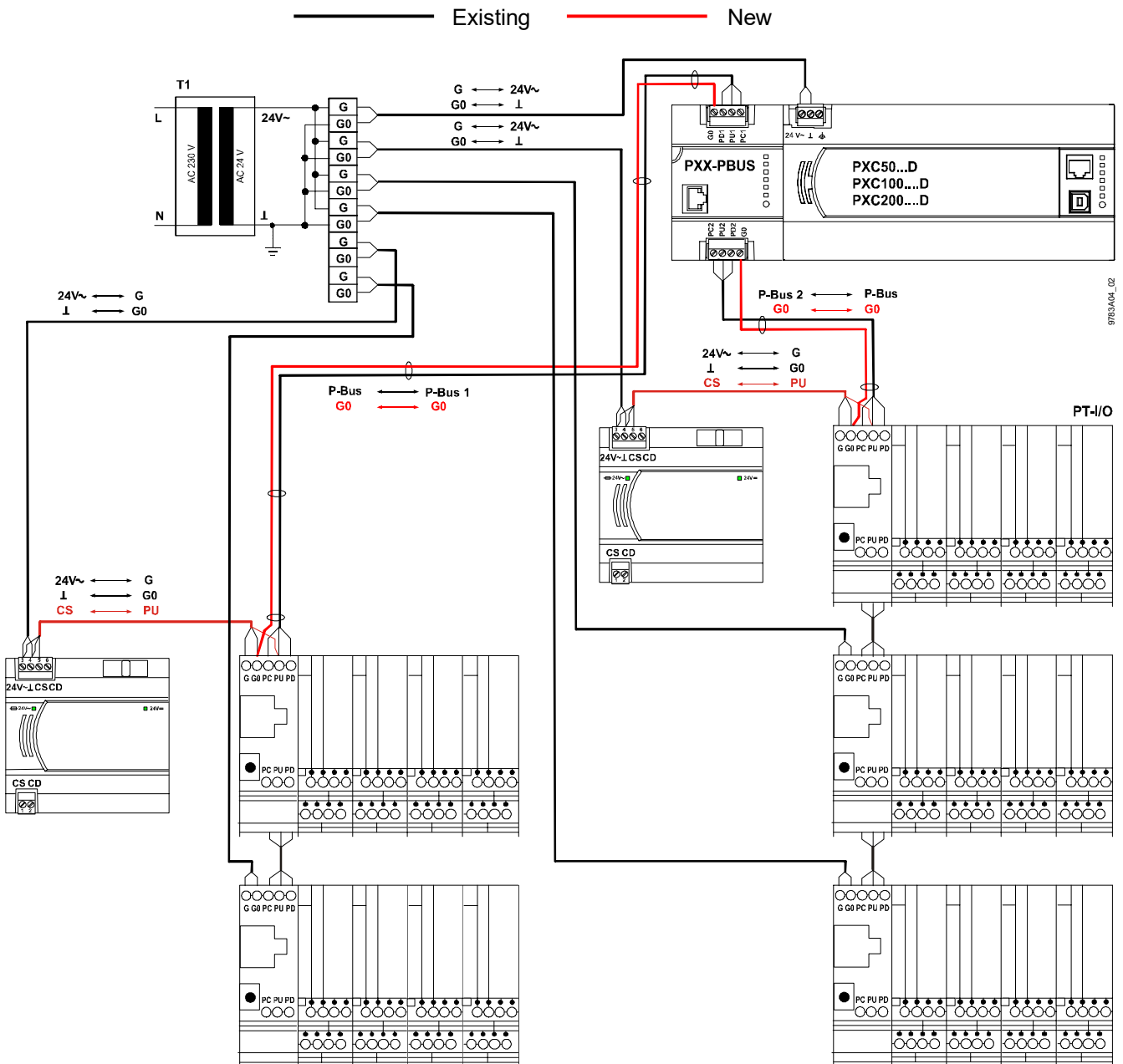

## Technical data

General device data	Power supply module	DC 24 V $\pm$ 20% (SELV) or DC 24 V class 2 (US) 54 mA, 1.4 W from automation station PXC50...D / PXC100...D / PXC200...D
P bus interface	Polling cycle on I/O modules Rate of transmission Signal level Wiring      Cross-section Simple line length (see P-bus, N8022) Line length (remote P-bus) (see P-bus, N8022)	0.3 s 62,5 kBaud DC +23 V and 0 / -5 V Min. 3 x 0.75 mm <sup>2</sup> Max. 50 m per P-bus terminal block Max. 200 m per P-bus terminal block
Connection terminals, pluggable	Design type Copper wire or copper stranded wires with ferrules Cu-strand without wire end sleeve Screwdriver Max. tightening torque	Pluggable screw terminals 1 x 0.6 mm dia. to 2.5mm <sup>2</sup> or 2 x 0.6 mm dia. to 1.0 mm <sup>2</sup> 1 x 0.6 mm dia. to 2.5 mm <sup>2</sup> or 2 x 0.6 mm dia. to 1.5 mm <sup>2</sup> Slot screws Screwdriver, size 1 <i>with shaft dia. <math>\leq</math> 4.5 mm</i> 0.6 Nm
Protection data	Housing protection standard Protection class	IP20 to EN 60529 III to EN 60730-1
Ambient conditions	Normal operation Temperature Humidity Transport Temperature Humidity	Class 3K5 to IEC 721 0 ... 50 °C < 85% r.h. Class 2K3 to IEC 721 - 25 ... 65 °C < 95% r.h.
Standards, directives and approvals	Product standard      EN 60730-1 Electromagnetic compatibility (Applications)	Automatic electrical controls for household and similar use For use in residential, commerce, light-industrial and industrial environments
Environmental compatibility	Product environmental declaration (contains data on RoHS compliance, materials composition, packaging, environmental benefit, disposal)	CM1T9283xx *) UL 916, <a href="http://ul.com/database">http://ul.com/database</a> CM1T9222en_C1 *) Eurasia conformity 47 CFR Part 15 Class B CM1E9283 *)
Dimensions	See "Dimensions"	
Weight	With/without packaging	0.129 kg / 0.140 kg

\*) The documents can be downloaded from <http://siemens.com/bt/download>.

**PXX-PBUS**

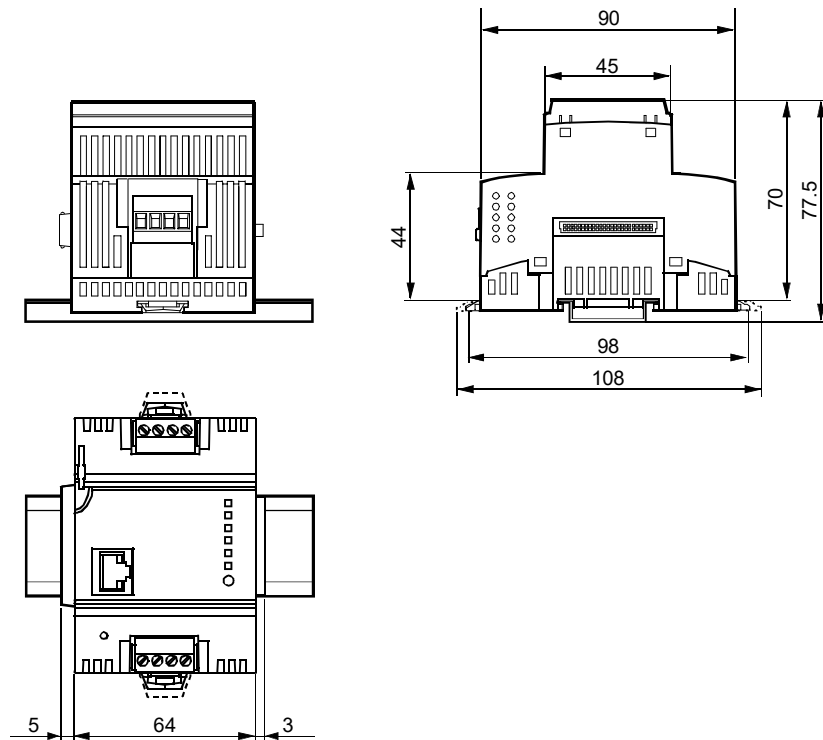

**PXX-PBUS with one automation station  
PXC50...D / PXC100...D /  
PXC200...D**

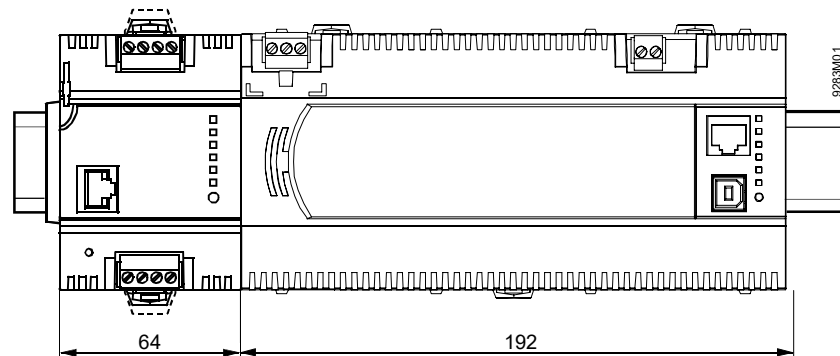

**Power supply module  
TXS1.12F10**

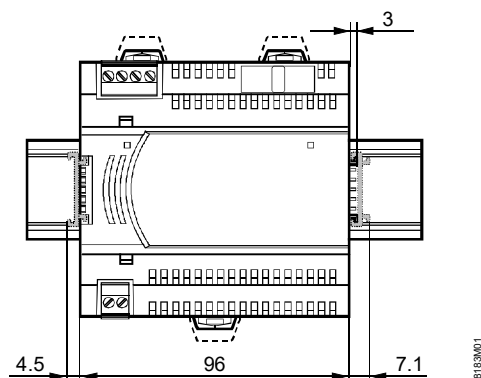

Issued by:  
Siemens Switzerland Ltd  
Smart Infrastructure  
Global Headquarters  
Theilerstrasse 1a  
CH-6300 Zug  
+41 58 724-2424  
[www.siemens.com/buildingtechnologies](http://www.siemens.com/buildingtechnologies)

© Siemens Switzerland Ltd 2012  
Delivery and technical specifications subject to change