

SIEMENS



BACnet PTEC Controller

Terminal Box (VAV) - Cooling Only, Application 6620

Application Note

Table of Contents

Overview	4
BACnet	5
Hardware Inputs	5
Room Unit Identification	6
Hardware Outputs.....	6
Ordering Notes	6
Sequence of Operation	7
Control Temperature Setpoints	7
CTL STPT Using Standard/Absolute Mode (Digital Room Unit, Revision 26 and later)	7
CTL STPT Using Warmer/Cooler Mode (Digital Room Unit, Revision 26 and later)	8
CTL STPT Using Standard/Absolute Mode (Analog or Digital Room Unit)	8
CTL STPT Using Warmer/Cooler Mode (Analog Room Unit Only)	8
Room Temperature, Room Temperature Offset and CTL TEMP.....	9
Day and Night Modes	9
Night Mode Override Switch	10
Control Loops	10
Calibration.....	11
Room Unit Operation	12
Sensor Select	12
Room CO2.....	12
Room RH.....	13
Room DEW POINT	13
Auto Discovery.....	13
Auto Addressing	13
PPCL STATUS	13
Fail Mode Operation	13
Application Notes.....	14
Wiring Diagram	14
Application 6620 Point Database	16

Overview



NOTE:

For information on applications with Firmware Revision Bx40 or earlier, see InfoLink and/or Asset Portal for documentation.

In Application 6620, the controller modulates the supply air damper of the terminal box for cooling. In order for it to work properly, the central air-handling unit must provide cool supply air.

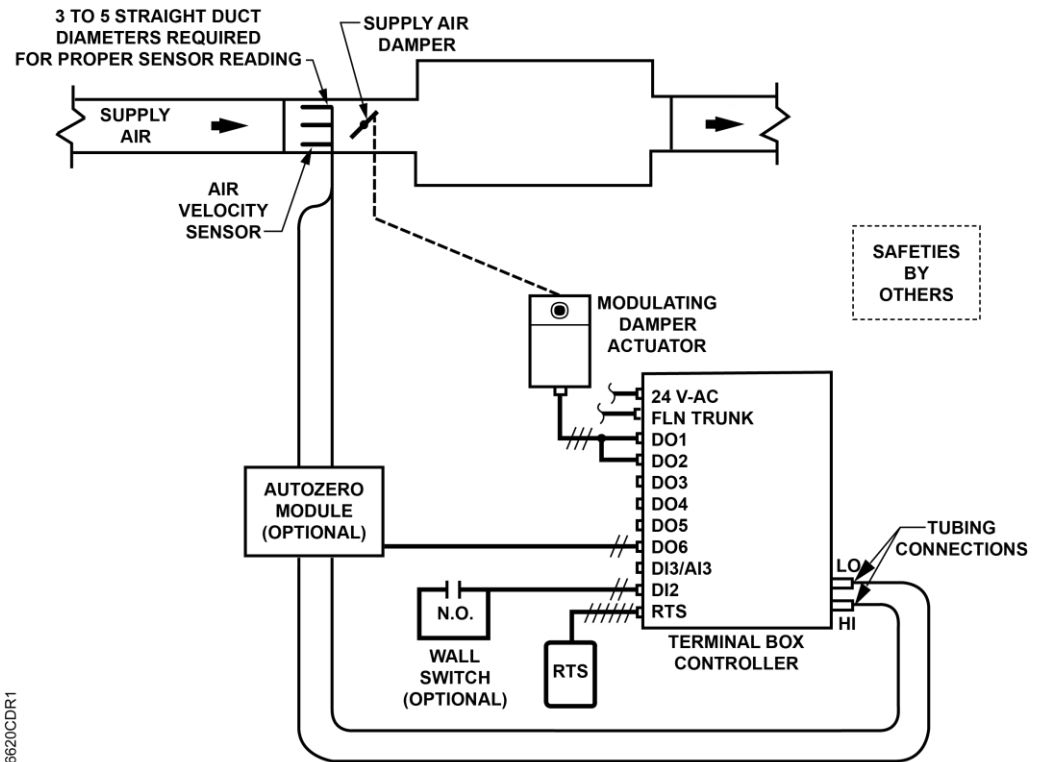

TEC6620CDR1

Room unit can also provide monitoring for humidity and/or CO2

Application 6620 – VAV Cooling Only Control Diagram.

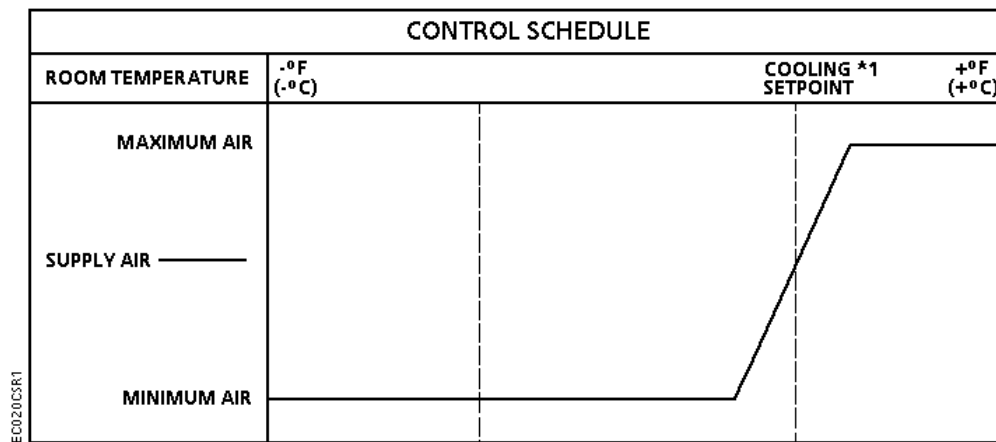

Application 6620 Control Schedule.

BACnet

The controller communicates using BACnet MS/TP protocol for open communications on BACnet MS/TP networks.

Product	Supported BIBBs	BIBB Name
BTEC/PTEC	DS-RP-B B	Data Sharing-Read Property-B
	DS-RPM-B	Data Sharing-Read Property Multiple-B
	DS-WP-B	Data Sharing-Write Property-B
	DM-DDB-B	Device Management-Dynamic Device Binding-B
	DM-DOB-B	Device Management-Dynamic Object Binding-B
	DM-DCC-B	Device Management-Device Communication Control-B
	DM-RD-B	Device Management-Reinitialize Device-B
	DM-BR-B	Device Management-Backup and Restore-B
	DM-OCD-B	Device Management-Object Creation and Deletion-B

Hardware Inputs

Analog

- Air velocity sensor
- Room temperature sensor
- Room temperature setpoint dial (optional)
- Auxiliary temperature sensor (100K or 10K selectable thermistor, optional)
- Duct temperature sensor (optional; PPCL commands can be used to perform a functional switch between heating and cooling supply.)

Digital

- Night/Unoccupied mode override (optional)
- Wall switch (optional)



NOTE:

Digital Room Units (Firmware Revision 26 and later) will update their controlled inputs without putting them Out Of Service. However, a command from an external source through the digital room unit will put the associated BACnet Input point Out Of Service.

Room Unit Identification

- For Analog Room Units – The revision number is visually identified by its case.
- For Digital Room Units (Firmware Revision 25 or earlier) – The revision number displays for 5 seconds when the room unit is first powered up. These room units will display `laptop` when a laptop is connected and will no longer update room temperature sensor values.
- For Digital Room Units (Firmware Revision 26 and later) – The revision number displays for 5 seconds when the room unit is first powered up or when a laptop is disconnected. These room units will continue to display and update the room temperature sensor values when a laptop is connected.

Hardware Outputs

Analog

- None

Digital

- Damper actuator (DO 1/DO 2)
- Autozero module (optional)

Ordering Notes

550-432PA Siemens BACnet PTEC Terminal Box (VAV) Controller

Sequence of Operation

The following paragraphs present the sequence of operation for Application 6620, VAV Cooling Only.

Control Temperature Setpoints

This application has a number of different room temperature setpoints (NGT CLG STPT, RM STPT DIAL, etc.). The application actually controls to CTL STPT. CTL STPT is set to different values depending on its override status, the time of day, and the type of RTS used.

CTL STPT is Overridden:

If CTL STPT is overridden, that value is used regardless of any other settings.

CTL STPT in Night Mode:

The controller is in Night Mode if DAY.NGT = NGT and NGT OVRD = NGT.

When the controller is in night mode, CTL STPT holds the value of NGT CLG STPT. When the controller is in night mode the value of RM STPT DIAL is ignored.

CTL STPT in Day Mode:

The controller is in Day Mode if DAY.NGT = DAY or NGT OVRD = DAY.

Without setpoint dial:

When the controller is in day mode and STPT DIAL = NO, CTL STPT holds the value of DAY CLG STPT.

With setpoint dial:

When the controller is in day mode and STPT DIAL = YES, CTL STPT holds a value based on RM STPT DIAL depending on your room unit model/revision.

The following sections describe the value of CTL STPT based on room unit type and configuration:

- CTL STPT using Standard/Absolute Mode (Digital Room Unit, Revision 26 and later)
- CTL STPT using Warmer/Cooler Mode (Digital Room Unit, Revision 26 and later)
- CTL STPT using Standard/Absolute Mode (Analog or Digital Room Unit)
- CTL STPT using Warmer/Cooler Mode (Analog Room Unit Only)

CTL STPT Using Standard/Absolute Mode (Digital Room Unit, Revision 26 and later)

Digital Room Unit (2200/2300 Series Firmware Revision 26 and later)

For all new digital room units, the value displayed and reported by the room unit is linked to the current cooling mode.

When STPT SPAN is set to 0, the room setpoint adjustment on the digital room unit will function in a standard mode. The range of the adjustment will be based on RM STPT MIN and RM STPT MAX.

CTL STPT is set equal to RM STPT DIAL. The values for RM STPT MIN and RM STPT MAX will be applied to limit RM STPT DIAL before it is copied into CTL STPT.

CTL STPT Using Warmer/Cooler Mode (Digital Room Unit, Revision 26 and later)

Digital Room Unit (2200/2300 Series Firmware Revision 26 and later)



NOTE:

The warmer-cooler function is only available with BACnet PTEC controllers (standard 66xx apps).

When STPT SPAN is set to a value > 0 , the room setpoint adjustment on the digital room unit will function in a warmer/cooler mode. The range of the adjustment will be calculated based on the current DAY CLG STPT and the STPT SPAN value. This will allow the Room Setpoint Dial to be incremented up or down from this setpoint by STPT SPAN.

CTL STPT is set equal to RM STPT DIAL. The values for RM STPT MIN and RM STPT MAX will be applied to limit RM STPT DIAL before it is copied into CTL STPT.

When SPTP SPAN > 0 , the minimum and maximum values for RM STPT DIAL are calculated as follows:

- Minimum lowest adjusted setpoint value is equal to DAY CLG STPT - STPT SPAN
- Maximum highest adjusted setpoint value is equal to DAY CLG STPT + STPT SPAN

CTL STPT Using Standard/Absolute Mode (Analog or Digital Room Unit)

Analog (Series 1000) or Digital Room Units (Firmware Revision 25 or earlier)

When STPT SPAN is set to 0, CLT STPT is set based on the value of the setpoint dial and the setpoint.



NOTE:

2200/2300 digital room units with Firmware Revision 25 or earlier are only compatible with standard room unit functionality (no warmer/cooler).

CTL STPT Using Warmer/Cooler Mode (Analog Room Unit Only)

Analog Room Unit (Series 1000)



NOTE:

The warmer-cooler function for analog room units (Series 1000) use the warmer/cooler scale of units with a warmer/cooler housing.

When SPTP SPAN > 0 , the minimum and maximum values for RM STPT DIAL are calculated as follows:

- Minimum lowest adjusted setpoint value is equal to DAY CLG STPT - STPT SPAN

- Maximum highest adjusted setpoint value is equal to DAY CLG STPT + STPT SPAN

The full range of the analog room unit slider will be mapped to a range of minimum setpoint value to maximum setpoint value.

CTL STPT is set equal to RM STPT DIAL. The values for RM STPT MIN and RM STPT MAX will be applied to limit RM STPT DIAL before it is copied into CTL STPT.

Example in Cooling Mode

If the STPT SPAN is set to 2.0 degrees, and the DAY CLG STPT is 76°F, the room unit slider will adjust the cooling setpoint from 74°F to 78°F.

Room Temperature, Room Temperature Offset and CTL TEMP

ROOM TEMP is the temperature that is being sensed by the room temperature sensor (RTS).

RMTMP OFFSET (or TEMP OFFSET) is a user-adjustable offset that will compensate for deviations between the value of ROOM TEMP and the actual room temperature.

CTL TEMP is the room temperature that is used for control purposes. In other words, what the application is trying to do is to maintain CTL TEMP at the control setpoint.

When CTL TEMP is not overridden, CTL TEMP and ROOM TEMP are related by the following equation:

$$\text{CTL TEMP} = \text{ROOM TEMP} + \text{RMTMP OFFSET (or TEMP OFFSET)}$$

If CTL TEMP is not overridden, then:

- The current value of ROOM TEMP (normal or overridden) is used to determine the value of CTL TEMP.
- If ROOM TEMP has a status of Failed, then last known good value of ROOM TEMP is used to determine the value of CTL TEMP.

Day and Night Modes

The day/night status of the space is determined by the status of DAY.NGT. The control of this point differs depending on whether the controller is monitoring the status of a wall switch or if the controller is connected to a field panel.

When a wall switch is physically connected to the termination strip on the controller at DI 2 (see the *Control Diagram* in the Overview section), and WALL SWITCH = YES, the controller monitors the status of DI 2. When the status of DI 2 is ON (the switch is closed), then DAY.NGT will be set to DAY indicating that the controller is in day mode. When the status is OFF (the switch is open), then DAY.NGT will be set to NIGHT indicating that the controller is in night mode.

When WALL SWITCH = NO, the controller does not monitor the status of the wall switch, even if one is connected to it. In this case, if the controller is operating stand-alone, then the controller stays in day mode all the time. If the controller is operating with centralized control (that is, it is connected to a field panel), then the field panel can send an operator or PPCL command to override the status of DAY.NGT.

Night Mode Override Switch

If an override switch is present on the room temperature sensor and a value (in hours) other than zero has been entered into OVRD TIME, pressing the override switch will reset the controller to DAY operational mode for the time period that is set in OVRD TIME. The status of NGT OVRD changes to DAY. After the override time elapses, the controller returns to night mode and the status of NGT OVRD changes back to NIGHT. The override switch on the room sensor will only affect the controller when it is in night mode.

Control Loops

The terminal box is controlled by two Proportional, Integral, and Derivative (PID) control loops; a temperature loop and a flow loop.

The temperature loop is a cooling loop. The active temperature loop maintains room temperature at the value in CTL STPT. See *Control Temperature Setpoints*.

Temperature Loop – A cooling loop that maintains room temperature at the value in CTL STPT. See *Control Temperature Setpoints*.

The temperature loop generates cooling loopout which is then used to generate FLOW STPT. FLOW STPT is the result of scaling the cooling loopout to the appropriate range of values determined by CLG FLOW MIN and CLG FLOW MAX. In order to scale it, the loopout is multiplied by the range (MAX – MIN) and then added to the minimum setpoint.

When CTL FLOW MIN \neq 0 CFM, FLOWSTPT \neq CLG LOOPOUT. The minimum flow setpoint is $(\text{CTL FLOW MIN} / \text{CLG FLOW MAX}) \times 100\%$ flow. And FLOW STPT is $[\text{CLG LOOPOUT} \times (100\% - \text{minimum setpoint})] + \text{minimum setpoint}$.

Example

If CTL FLOW MIN = 200 cfm, and CLG FLOW MAX = 1000 cfm, the minimum flow setpoint is $(200 \text{ cfm} / 1000 \text{ cfm}) \times 100\% \text{ flow} = 20\%$.

When CLG LOOPOUT is 0%, FLOW STPT = 20% flow.

$[0\% \times (100\% - 20\%)] + 20\% = 20\%$

This ensures that the airflow out of the terminal box is no less than CTL FLOW MIN.

When CLG LOOPOUT is 50%, FLOW STPT = 60% flow.

$[50\% \times (100\% - 20\%)] + 20\% = 60\%$

When CLG LOOPOUT is 100%, FLOW STPT = 100% flow.

$[100\% \times (100\% - 20\%)] + 20\% = 100\%$

Advanced PID algorithm for the temperature control loops is employed to provide stability and to reduce unnecessary changes in the Flow setpoint when the room temperature is at or near the room temperature setpoint.

Flow Loop – The flow loop maintains FLOW STPT by modulating the supply air damper, DMPR COMD. The flow loop maintains the airflow between CTL FLOW MIN and CTL FLOW MAX.

DAY/OCCUPIED MODE

When the controller is in day cooling mode:

- CTL FLOW MIN = larger of CLG FLOW MIN and VENT DMD MIN, and CTL FLOW MAX = CLG FLOW MAX.

NIGHT/UNOCCUPIED MODE

When the controller is in night cooling mode:

- CTL FLOW MIN = NGT FLOW MIN, and CTL FLOW MAX = CLG FLOW MAX.

To enhance stable flow control, an advanced algorithm is used to calculate a controllable setpoint as the value approaches zero cfm (lps).

You can set CLG FLOW MIN equal to, but not greater than, CLG FLOW MAX. If the minimum and maximum values are set equal, the flow loop becomes a constant volume loop and loses its ability to control temperature.

FLOW is the input value for the flow loop. It is calculated as a percentage based on where AIR VOLUME is between 0 cfm and CTL FLOW MAX. This percentage is referred to as % flow.

- If AIR VOLUME = 0 cfm, FLOW is 0% flow.
- If AIR VOLUME = CTL FLOW MAX, FLOW is 100% flow.

The low limit of FLOW STPT will be the percentage that corresponds to the volume given in CTL FLOW MIN. This percentage can be calculated as:

$$(\text{CTL FLOW MIN} / \text{CTL FLOW MAX}) \times 100\% \text{ flow}$$

The flow loop ensures that the supply air will not be less than CTL FLOW MIN.

Example

If CTL FLOW MIN = 250 cfm, and CTL FLOW MAX = 1000 cfm,
the low limit of FLOW STPT = $(250 \text{ cfm} / 1000 \text{ cfm}) \times 100\% \text{ flow}$
= $0.25 \times 100\% \text{ flow}$
= 25% flow.

Since 25% of 1000 cfm = 250 cfm, the minimum airflow out of the terminal box will be 250 cfm.

Calibration

Calibration of the controller's internal air velocity sensor(s) is periodically required to maintain accurate air velocity readings. CAL SETUP is set with the desired calibration option during controller startup.

Depending on the value of CAL SETUP, calibration may be set to take place automatically or manually. If CAL AIR = YES, calibration is in progress.

- For a controller used without an Autozero Module (CAL MODULE, = NO), the damper is commanded closed to get a zero airflow reading during calibration.
- For a controller used with an Autozero Module (CAL MODULE = YES), calibration occurs without closing the damper.

At the end of a calibration sequence, CAL AIR automatically returns to NO. A status of NO indicates that the controller is not in a calibration sequence.

Floating Control Actuation Auto-correct

In addition to the existing options for floating control actuator full stroke actions, all floating control actuators are provided with additional logic to fully drive open or closed when commanded to 100% or 0%.

Room Unit Operation

Sensor Select

SENSOR SEL is a configurable, enumerated point (values are additive). This point tells the controller what type of room unit is being used and how to handle loss of data. It also provides the ability to enable the optional RH and CO₂ sensors and which thermistor type is connected.

Room Temperature, Setpoint, RH and CO₂

- When the digital room unit (Series 2200/2300) is used, SENSOR SEL selects the source for temperature and setpoint and enables a loss of communications indication:
 - Temperature/Setpoint enable and supervision for fail communications (temperature) with a value of 1.
 - Relative humidity enable and supervision for fail communications with a value of 2.
 - CO₂ enable and supervision for fail communications with a value of 4.
- When the analog room unit (Series 1000/2000) is used, default temperature sensing (0) from an analog room unit is enabled (relative humidity and CO₂ sensing are not available and should not be selected).

Thermistor Inputs

- Default for either input is 10K.
- To enable 100K thermistor on input, see the following table for additive values of 8 or 16.

Other Inputs (only available on Digital Room Unit)

- Use the following table to select and enable communications supervision of room temperature/setpoint dial, relative humidity and CO₂ for additive values of 1, 2 and 4.

SENSOR SEL Value * (additive)	Description (include values to enable feature)
1	Select Digital Room Unit (for temperature sensing and setpoint dial)
2	Relative Humidity (RH) sensing
4	CO ₂ sensing
8	If short board: 100K Ω thermistor on AI 3 (else input is 10K Ω) If long board: 100K Ω thermistor on AI 5 (else input is 10K Ω)
16	Long board only: 100K Ω thermistor on AI 4 (else input is 10K Ω)

Room CO₂

RM CO₂ displays the CO₂ value in units of parts-per-million (PPM). RM CO₂ (from the digital 2200/2300 room units) can be used with PPCL in the PTEC controller or unbundled for control or monitoring purposes.

Room RH

RM RH displays the relative humidity value in percent. RM RH can be used for PPCL in the PTEC or unbundled for control or monitoring purposes.

Room DEW POINT

The controller provides a calculation for DEW POINT temperature in Fahrenheit degrees (or Celsius degrees) using room temperature (using CLT TEMP) and room humidity (using RM RH). This calculation is valid for ranges of 55°F (12.8°C) to 95°F (35°C) and 20 to 100% relative humidity.

Auto Discovery

Auto Discovery allows you to automatically discover and identify PTEC controllers on the BACnet MS/TP Network. There are two basic configurations:

- Devices not configured with an address. (Devices are discovered by their unique serial number.)
- Devices configured with an address and available for modification.

Auto Addressing

Auto Addressing allows you to automatically assign device addresses to a PTEC controller on the BACnet MS/TP Network. If a controller is not configured with a MAC address, you have the option to auto-address or manually address the controller. During this time the baud rate is automatically detected by the controller.

Controller(s) must be connected on the BACnet/IP network in order for automatic addressing to occur.

PPCL STATUS

PPCL STATUS displays LOADED or EMPTY.

- LOADED = PPCL programming is present in the controller. A new application number must be assigned (12000 through 12999).
- EMPTY = NO PPCL programming is present.

The maximum number of PPCL dynamic points is 15.

Fail Mode Operation

If the air velocity sensor fails, the controller uses pressure dependent control. The temperature loop controls the operation of the damper.

If the room temperature sensor fails, the controller operates using the last known temperature value.

Application Notes

- If temperature swings in the room are excessive or there is trouble maintaining the setpoint, the cooling loop needs to be tuned. If FLOW is oscillating while FLOW STPT is constant, the flow loop requires tuning.
- The controller, as shipped from the factory, keeps all associated equipment OFF. See the appropriate *Start-up Procedures* for information on how to release the controller and its equipment to application control.
- Spare DOs can be used as auxiliary points that are controlled by the field panel after being defined in the field panel's database. DO 3 and DO 4 or DO 5 and DO 6 may be used as auxiliary motor points. If using a pair of spare DOs to control a motor, you must unbundle the corresponding motor command point.

Wiring Diagram



⚠ CAUTION

The controller's DOs control 24 Vac loads only. The maximum rating is 12 VA for each DO. An external interposing relay is required for any of the following:

- VA requirements higher than the maximum
- 110 or 220 Vac requirements
- DC power requirements
- Separate transformers used to power the load
(for example part number 540-147, Terminal Equipment Controller Relay Module)



NOTE:

Thermistor inputs are 10K (default) or 100K software selectable (AUX TEMP AI X).

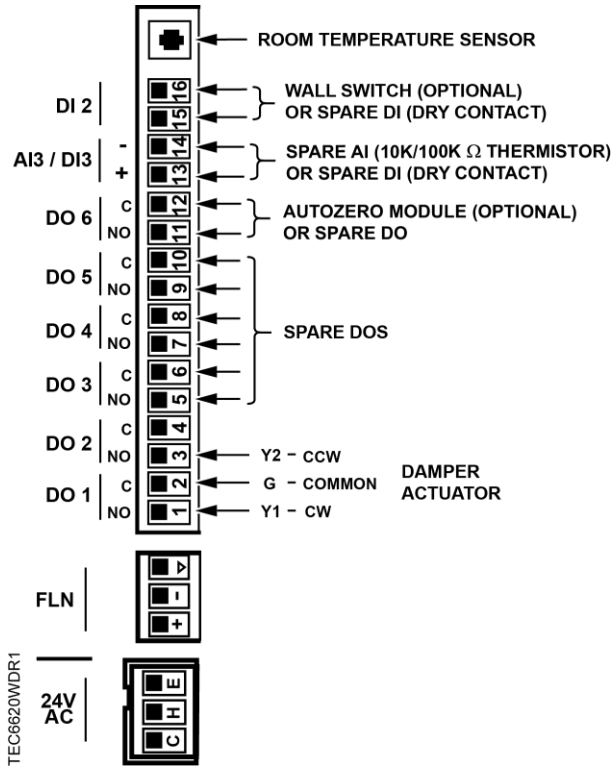

Application 6620 - VAV Cooling Only.

Application 6620 Point Database

Object Type ¹	Object Instance (Point Number)	Object Name (Descriptor)	Factory Default (SI Units) ²	Engr Units (SI Units)	Range	Active Text	Inactive Text
AO	1	CTLR ADDRESS	255	--	0-255	--	--
AO	2	APPLICATION	6688	--	0-32767	--	--
AO	3	RMTMP OFFSET	0.0 (0.0)	DEG F (DEG C)	-31.75-32	--	--
AI	{04}	ROOM TEMP	74.0 (23.44888)	DEG F (DEG C)	48-111.75	--	--
AO	6	DAY CLG STPT	74.0 (23.44888)	DEG F (DEG C)	48-111.75	--	--
AO	8	NGT CLG STPT	82.0 (27.92888)	DEG F (DEG C)	48-111.75	--	--
AO	11	RM STPT MIN	55.0 (12.80888)	DEG F (DEG C)	48-111.75	--	--
AO	12	RM STPT MAX	90.0 (32.40888)	DEG F (DEG C)	48-111.75	--	--
AI	{13}	RM STPT DIAL	74.0 (23.44888)	DEG F (DEG C)	48-111.75	--	--
BO	14	STPT DIAL	NO	--	Binary	YES	NO
AI	{15}	AUX TEMP AI3	74.0 (23.495556)	DEG F (DEG C)	37.5-165	--	--
BO	18	WALL SWITCH	NO	--	Binary	YES	NO
BI	{19}	DI OVRD SW	OFF	--	Binary	ON	OFF
AO	20	OVRD TIME	0	HRS	0-255	--	--
BO	{21}	NGT OVRD	NIGHT	--	Binary	NIGHT	DAY
BI	{24}	DI 2	OFF	--	Binary	ON	OFF
BI	{25}	DI 3	OFF	--	Binary	ON	OFF
BO	{29}	DAY.NGT	DAY	--	Binary	NIGHT	DAY
AO	31	CLG FLOW MIN	220 (103.818)	CFM (LPS)	0-131068	--	--
AO	32	CLG FLOW MAX	2200 (1038.18)	CFM (LPS)	0-131068	--	--
AI	{35}	AIR VOLUME	0 (0.0)	CFM (LPS)	0-131068	--	--
AO	36	FLOW COEFF	1	--	0-2.55	--	--
AO	{37}	MTR3 COMD	0	PCT	0-102	--	--
AO	{38}	MTR3 POS	0	PCT	0-102	--	--
AO	39	MTR3 TIMING	130	SEC	0-511	--	--
BO	{41}	DO 1	OFF	--	Binary	ON	OFF
BO	{42}	DO 2	OFF	--	Binary	ON	OFF

Object Type ¹	Object Instance (Point Number)	Object Name (Descriptor)	Factory Default (SI Units) ²	Engr Units (SI Units)	Range	Active Text	Inactive Text
BO	{43}	DO 3	OFF	--	Binary	ON	OFF
BO	{44}	DO 4	OFF	--	Binary	ON	OFF
BO	{45}	DO 5	OFF	--	Binary	ON	OFF
BO	{46}	DO 6	OFF	--	Binary	ON	OFF
AO	{48}	DMPR COMD	0	PCT	0-102	--	--
AO	{49}	DMPR POS	0	PCT	0-102	--	--
AO	51	MTR1 TIMING	95	SEC	0-511	--	--
AO	{52}	MTR2 COMD	0	PCT	0-102	--	--
AO	{53}	MTR2 POS	0	PCT	0-102	--	--
AO	55	MTR2 TIMING	130	SEC	0-511	--	--
AO	56	DMPR ROT ANG	90	--	0-255	--	--
AO	58	MTR SETUP	0	--	0-255	--	--
AO	59	DO DIR. REV	0	--	0-255	--	--
AO	63	CLG P GAIN	20.0 (36.0)	--	0-63.75	--	--
AO	64	CLG I GAIN	0.01 (0.018)	--	0-1.023	--	--
AO	65	CLG D GAIN	0 (0.0)	--	0-510	--	--
AO	71	FLOW P GAIN	0	--	0-51.15	--	--
AO	72	FLOW I GAIN	0.01	--	0-1.023	--	--
AO	73	FLOW D GAIN	0	--	0-510	--	--
AO	74	FLOW BIAS	50	PCT	0-102	--	--
AO	{75}	FLOW	0	PCT	0-1023.75	--	--
AO	{76}	CTL FLOW MIN	220 (103.818)	CFM (LPS)	0-131068	--	--
AO	{77}	CTL FLOW MAX	2200 (1038.18)	CFM (LPS)	0-131068	--	--
AO	{78}	CTL TEMP	74.0 (23.44888)	DEG F (DEG C)	48-111.75	--	--
AO	{79}	CLG LOOPOUT	0	PCT	0-102	--	--
BO	87	CAL MODULE	NO	--	Binary	YES	NO
AO	{92}	CTL STPT	74.0 (23.44888)	DEG F (DEG C)	48-111.75	--	--
AO	{93}	FLOW STPT	0	PCT	0-255.75	--	--
BO	{94}	CAL AIR	NO	--	Binary	YES	NO
AO	95	CAL SETUP	4	--	0-255	--	--
AO	96	CAL TIMER	12	HRS	0-255	--	--
AO	97	DUCT AREA	1.0 (0.09292)	SQ. FT (SQ M)	0-6.375	--	--
AO	98	LOOP TIME	5	SEC	0-255	--	--

Object Type ¹	Object Instance (Point Number)	Object Name (Descriptor)	Factory Default (SI Units) ²	Engr Units (SI Units)	Range	Active Text	Inactive Text
AO	{99}	ERROR STATUS	0	--	0-255	--	--
AO	104	NGT FLOW MIN	0 (0.0)	CFM (LPS)	0-131068	--	--
AO	{105}	VENT DMD MIN	0 (0.0)	CFM (LPS)	0-131068	--	--
AO	106	STPT SPAN	0.0 (0.0)	DEG F (DEG C)	0-63.75	--	--
AO	{121}	DEW POINT	-40.0 (-40.0)	DEG F (DEG C)	-40-1598.35	--	--
AO	124	SENSOR SEL	0	--	0-255	--	--
AI	{125}	RM CO2	1000	PPM	0-8191	--	--
AI	{126}	RM RH	50	PCT	0-102	--	--
BO	{127}	PPCL STATE	EMPTY	--	Binary	LOADED	EMPTY

- 1) Object Types are; Analog Input (AI), Analog Output (AO), Binary Input (BI) and Binary Output (BO).
- 2) A single value in a column means that the value is the same in English units and in SI units.
- 3) Point numbers that appear in brackets { } may be unbundled at the field panel.