

de	Montageanleitung	6-Weg druckunabhängiger Regelkugelhahn (PICV)
en	Mounting instructions	6-way pressure independent control ball valve (PICV)
fr	Instructions de montage	Vanne de réglage à boisseau sphérique indépendante de la pression (PICV) à 6 voies
sv	Monteringsinstruktion	6-vägs tryckoberoende reglerkulventil (PICV)
nl	Montage-aanwijzing	6-weg drukonafhankelijke regelkogelkraan (PICV)
it	Istruzioni di montaggio	Valvola a sfera die controllo indipendente dall pressione (PICV) a 6 vie
fi	Asennusohje	6-teinen paineesta riippumaton säätöpalloventtiili (PICV)
es	Instrucciones de montaje	Válvula de bola de control independiente de la presión (PICV) de 6 vías
da	Monteringsvejledning	6-vejs trykuafhængig kontrolkulventil (PICV)
pl	Instrukcja montażu	6-drogowy niezależny od ciśnienia zawór regulacyjny kulowy (PICV)
cz	Montážní návod	6cestný tlakově nezávislý regulační kulový ventil (PICV)
el	Οδηγίες εγκατάστασης	6-οδη σφαιρική βαλβίδα ρύθμισης ανεξάρτητη από πίεση (PICV)
ru	Инструкция по установке	6-ходовой независимый от давления регулирующий шаровой клапан (PICV)
tr	Montaj talimatları	6 yollu basınçtan bağımsız kontrollü küresel vana (PICV)
zh	安裝指導	6 通道压力独立控制球阀

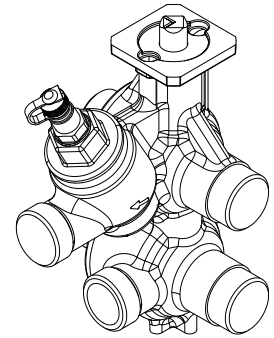

VWPG51..Q

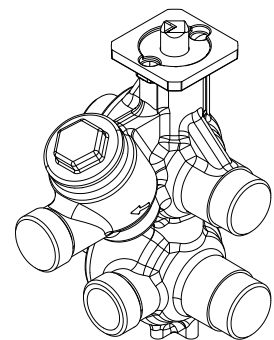

VWPG51..

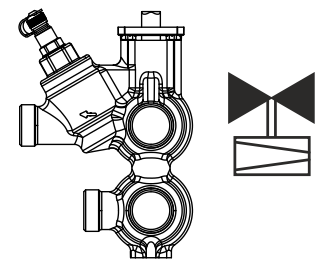
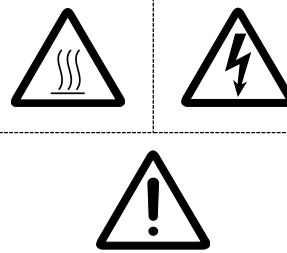
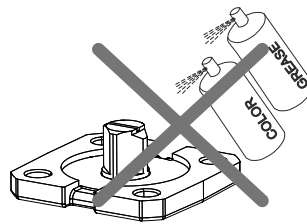
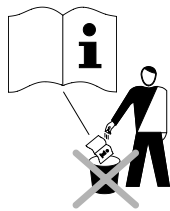

∅ : 0...100 %

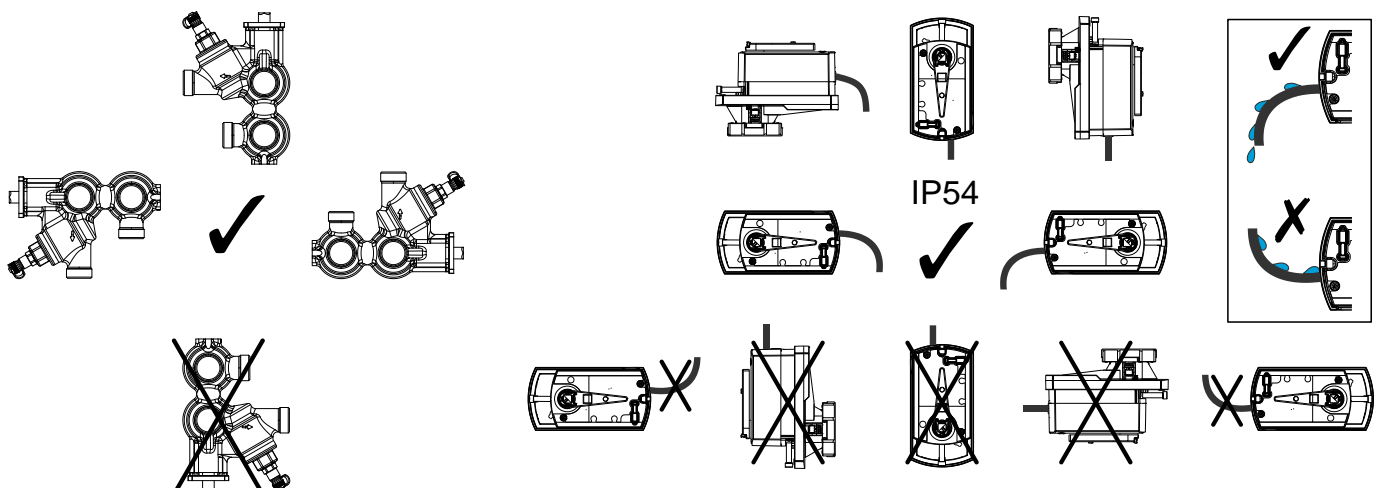

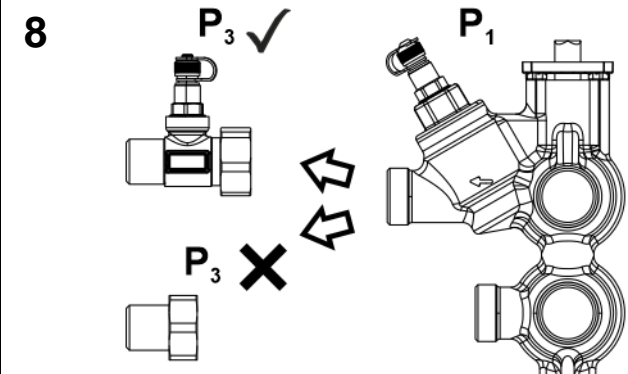
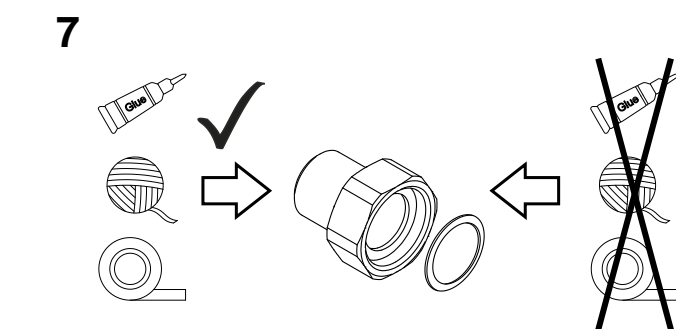
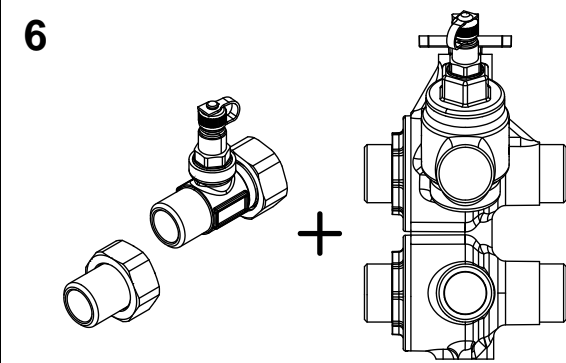
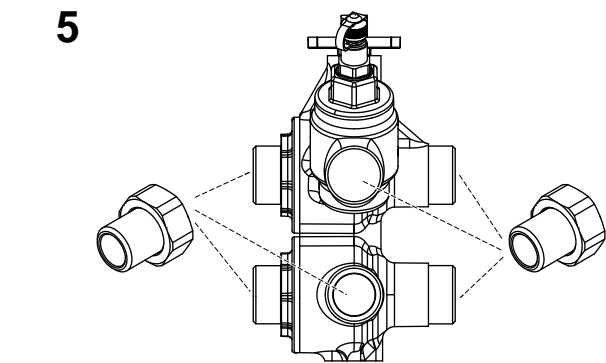
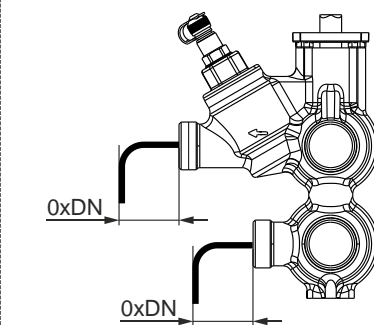
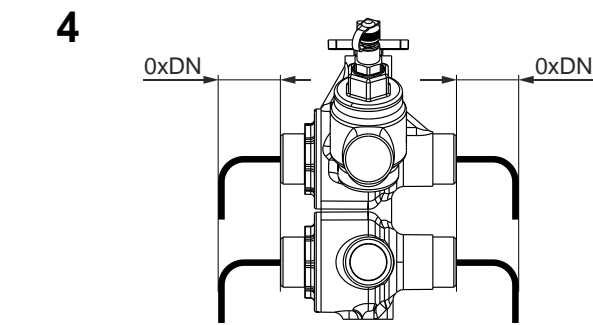
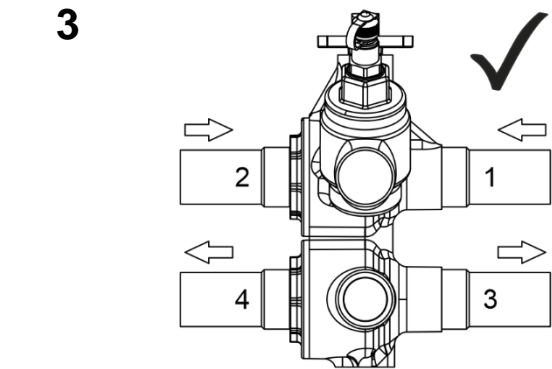
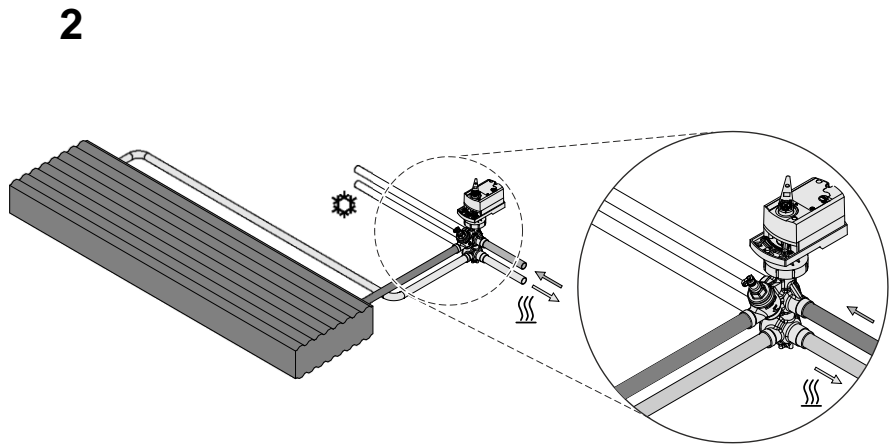
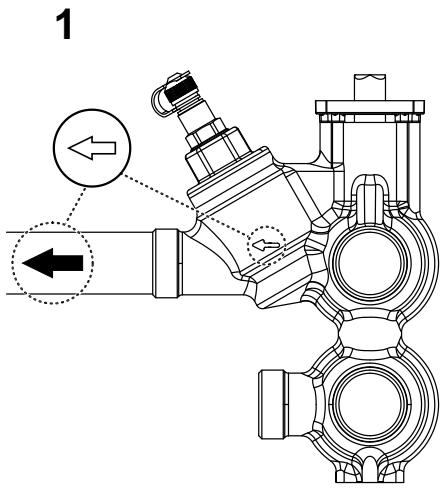

9

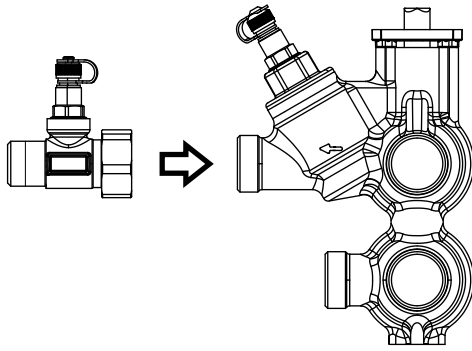

ΔP
kPa
bar
PSI
 $\Delta P = P_1 - P_3$

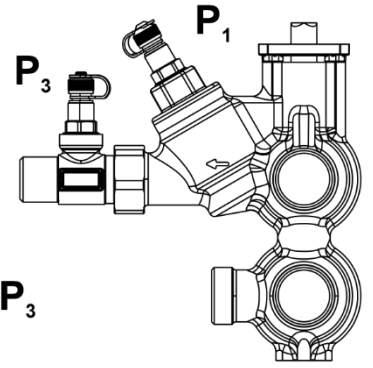

10

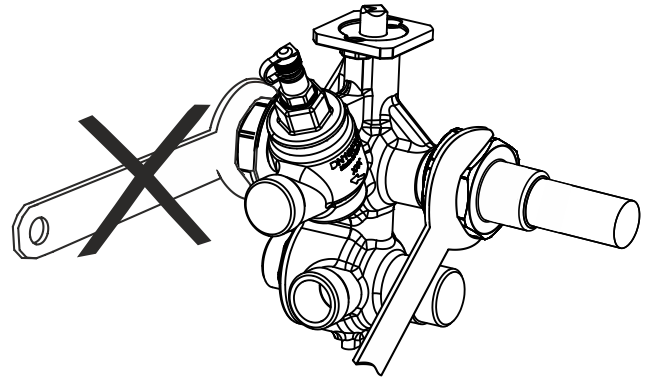
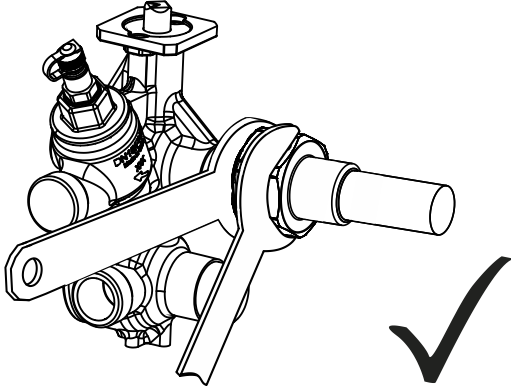

11

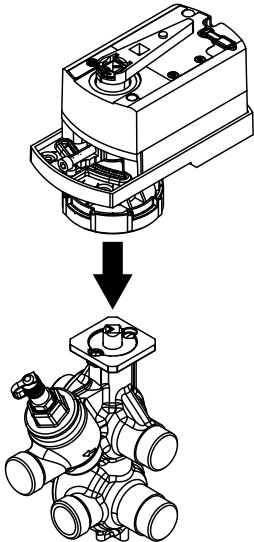

12

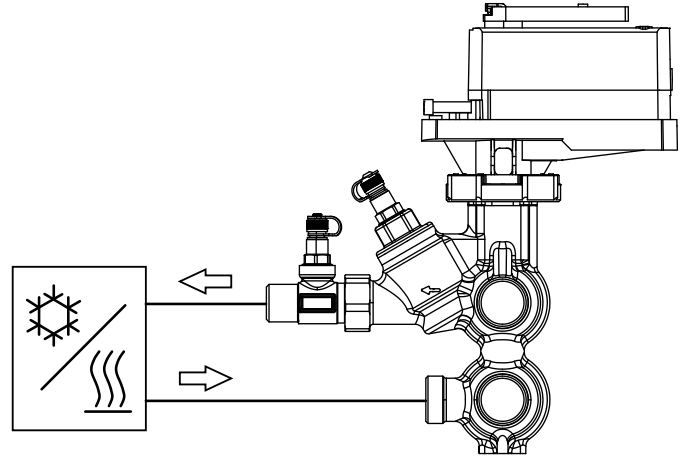
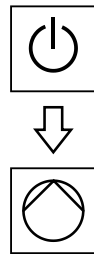

13

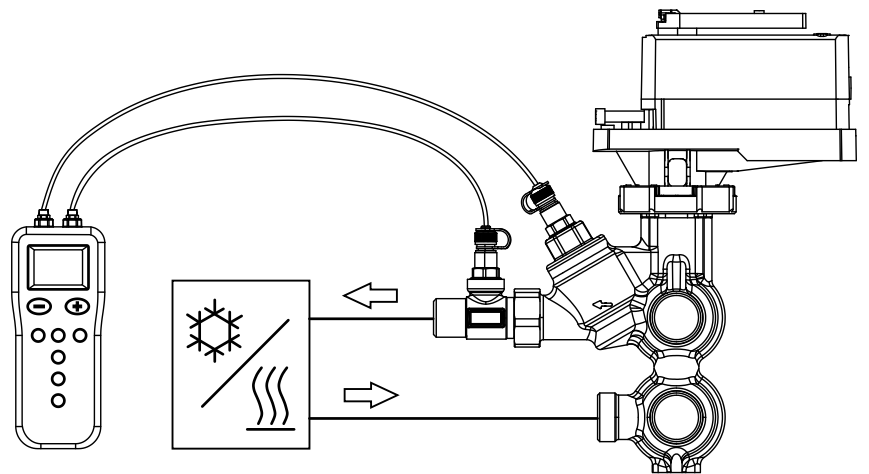

14

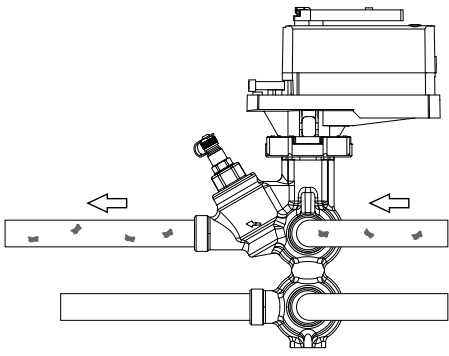

14.1

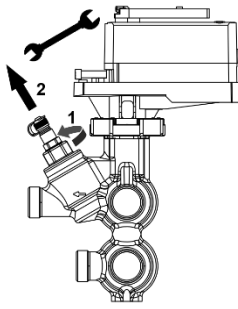

14.2

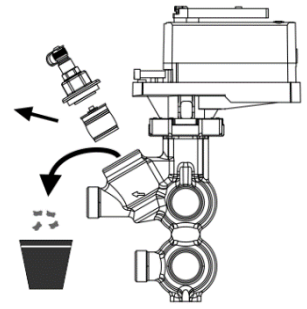

14.3

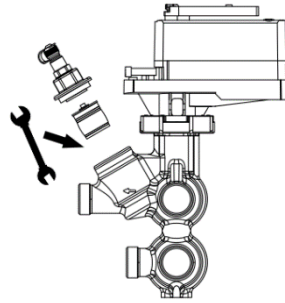

14.4

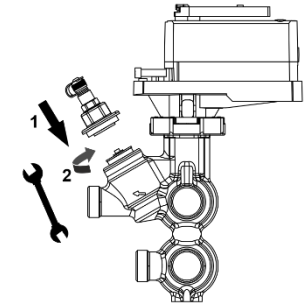

15

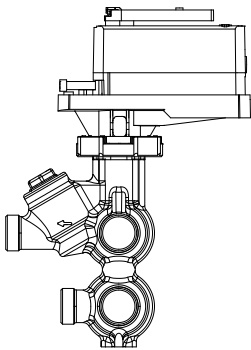

15.1

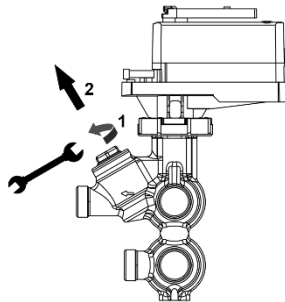

15.2

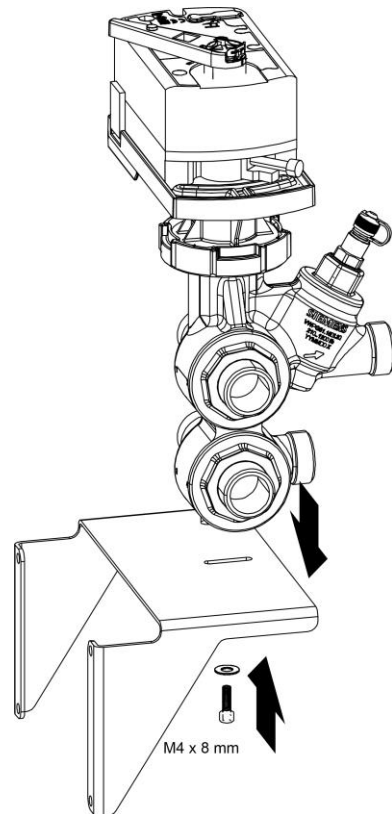
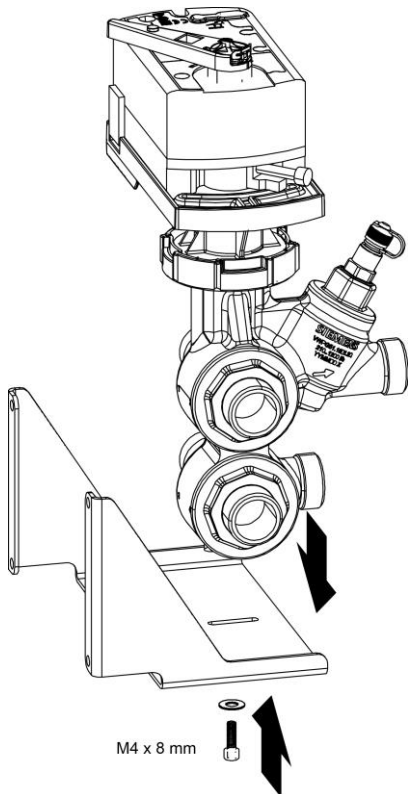
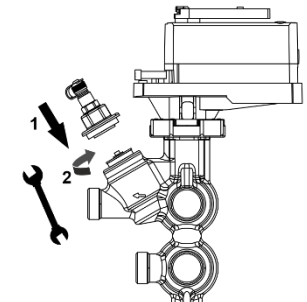

de	Inbetriebnahmehinweise	PICVs müssen bei der Spülung und beim Drucktest des Systems geöffnet sein. Druckschläge können geschlossene PICVs beschädigen. Die Voreinstellungstabellen (Seite 6) geben den zu erwartenden Nenndurchfluss an. Während der Inbetriebnahme ist zu prüfen, ob die aktuellen Voreinstellung der geplanten Auslegung entsprechen. Eine weitere Anpassung der Voreinstellung kann unter Umständen erforderlich sein, um den notwendigen Durchfluss zu erhalten.
en	Commissioning notes	The PICVs have to be open when flushing or pressure testing the system. Strong water hammer can damage closed PICVs. The presetting tables (page 6) indicate the expected nominal volumetric flow. During commissioning, check whether current pre-settings correspond to planned design. Further adjustment of pre-settings may be required to achieve needed volumetric flow.
fr	Indications pour la mise en service	Lors du rinçage ou de l'essai de pression de l'installation, les PICVs doivent être ouvertes. Elles risqueraient d'être endommagées par des coups de bélier en position fermée. Les tableaux de pré-réglage (page 6) indique le débit nominal attendu. Pendant la mise en service, il faut vérifier si le pré-réglage actuel correspond à la conception prévue. Ajustement supplémentaire du pré-réglage peut être nécessaire pour obtenir le débit nécessaire.
sv	Igångskörningsinstruktioner	Vid genomspolning eller trycktest av anläggningen måste PICV-ventilerna vara öppna. Kraftiga tryckstötter kan skada den stängda PICV-ventilen. Förinställningstabellerna (sidan 6) anger det förväntade nominella volymflödet. Under idrifttagningen, kontrollera om den aktuella förinställningen motsvarar önskat dimensionering. Ytterligare justering av förinställningen kan vara nödvändig för att erhålla önskat volymflöde.
nl	Aanwijzing voor de inbedrijfstelling	De PICVs moeten tijdens afpersen en spoelen van de installatie zijn geopend. Drukstoten kunnen gesloten PICVs beschadigen. De voorinstellingstabellen (pagina 6) geven het verwachte nominale debiet aan. Tijdens de inbedrijfstelling moet worden gecontroleerd of de huidige voorinstelling overeenkomt met het geplande ontwerp. Onder bepaalde omstandigheden kan het nodig zijn de voorinstelling verder aan te passen om het benodigde debiet te verkrijgen.
it	Note per la messa in servizio	Le valvole PICV devono essere aperte durante il lavaggio o la prova pressione di prova dell'impianto, i forti colpi d'ariete potrebbero danneggiare l'impianto se le valvole PICV sono chiuse. La tabella (pagina 6) riporta i valori di prerogolazione per la selezione della portata nominale desiderata. Durante la messa in servizio, controllare se le prerogolazioni impostate corrispondono ai dati di progetto. Potrebbe essere necessaria un'ulteriore regolazione delle preimpostazioni per ottenere la portata volumetrica necessaria.
fi	Käyttöönotto-ohjeet	PICV-venttiilien tulee olla auki verkoston huuhtelun ja painetestauksen aikana. Paineiskut saattaa vaurioittaa kiinni olevaa PICV-venttiilejä. siasetustaulukoissa (sivu 6) ilmoitetaan odotettavissa oleva nimellisvirtausnopeus. Käyttöönoton yhteydessä tarkista onko esiasetus suunnitelman mukainen. Esiasetuksien muuttaminen voi olla tarpeen halutun virtauksen saavuttamiseksi.
es	Notas de puesta en marcha	Las PICVs tienen que estar abiertas durante la limpieza de tuberías o cuando se realice la prueba de presión del sistema. Un golpe de ariete fuerte puede dañar las PICVs que permanezcan cerradas. Las tablas de preajustes (página 6) indican el caudal volumétrico nominal esperado. Durante la puesta en marcha, compruebe si los preajustes actuales se corresponden con el diseño previsto. Es posible que se requieran ajustes adicionales de los preajustes para lograr el flujo volumétrico necesario.
da	Idriftsættelsesinstruktioner	Ved gennemskylning eller trykafprøvning af anlægget skal PICV-ventilerne være åbne. Kraftige trykstød i systemet kan beskadige lukkede PICV-ventiler. Tabellerne (side 6) over ventilerne forindstillinger viser de forventede nominelle volumenflow. Under idriftsættelsen anbefales at kontrollere, om den aktuelle forindstilling modsvarer det dimensionerede flow. Yderligere justering af forindstillingen kan være påkrævet for at opnå det nødvendige volumenflow.
pl	Uwaga do uruchomienia	Zawory PICV muszą być otwarte podczas płukania instalacji czy próby ciśnieniowej. Zamknięte zawory mogą ulec uszkodzeniu na skutek silnego uderzenia hydraulicznego. Tabele nastaw (strona 6) przedstawiają oczekiwane nominalne natężenie przepływu. Podczas uruchomienia sprawdzić czy ustawione nastawy odpowiadają przepływowi projektowym. Późniejsza korekcja nastaw może być potrzebna do uzyskania wymaganego przepływu objętościowego.
cz	Montážní návod	PICVs musí být při proplachování nebo při tlakových zkouškách systému otevřeny. Silné tlakové rázy mohou poškodit uzavřené ventily PICV. Tabulky přednastavení (strana 6) udávají očekávaný jmenovitý objemový průtok. Při uvádění do provozu zkontrolujte, zda přednastavení souhlasí s projektovanými hodnotami. K dosažení potřebného průtoku může být nutná další úprava přednastavení.
el	Κατά την εγκατάσταση	Οι βάνες Combi (PICVs) θα πρέπει να είναι ανοιχτές κατά τον καθαρισμό ή τη δοκιμή πρεσαρίσματος του δικτύου. Ένα ισχυρό υδραυλικό πλήγμα θα μπορούσε να καταστρέψει μία κλειστή PICV. Οι πίνακες προ-ρύθμισης (σελίδα 6) υποδεικνύουν την αναμενόμενη ονομαστική παροχή. Κατά τη θέση σε λειτουργία, ελέγξτε εάν οι τρέχουσες προρυθμίσεις αντιστοιχούν στην προγραμματισμένη σχεδίαση. Μπορεί να απαιτηθεί περαιτέρω προσαρμογή των προκαθορισμένων ρυθμίσεων για την εξασφάλιση της απαιτούμενης παροχής.
ru	Замечания по наладке	Комбинированные клапаны (PICVs) должны быть открыты во время промывки или опрессовки системы. Сильный гидроудар может повредить закрытые клапаны PICV. В таблицах предварительных настроек (стр. 6) указан ожидаемый номинальный объемный расход. При вводе в эксплуатацию проверьте, соответствуют ли текущие предварительные настройки запроектированным значениям. Для достижения необходимого объемного расхода может потребоваться дополнительная регулировка предварительных настроек.
tr	Devreye alma notları	Sistem yıkanırken veya basınç testi yapılırken PICV'ler açık olmalıdır. Güçlü su darbesi, kapalı PICV'lere zarar verebilir. Ön ayar tabloları (sayfa 6) beklenen nominal hacimsel akışı gösterir. Devreye alma sırasında mevcut ön ayarların planlanan tasarımı uygun olup olmadığını kontrol edin. Gereklî hacimsel akışı elde etmek için ön ayarların düzenlenmesi gerekebilir.

在系统冲洗和试压的过程中，一体阀需处于全开状态。强烈的水锤会损坏处于关闭状态的一体阀。

预设表（第 6 页）显示了预期的标称体积流量。在调试过程中，检查当前的预设置是否符合计划设计。可能需要进一步调整预设值，以达到所需的体积流量。

VWPG51.15L0.9Q, VWPG51.15L0.9
820 l/h nominal

\dot{V} [l/h]	35	43	58	73	86	99	117	142	166	221	276	346	432	518	628	738	820
Scale	0.5	0.6	0.8	1.0	1.2	1.4	1.6	1.8	2.0	2.2	2.4	2.6	2.8	3.0	3.2	3.4	4.0
Δp_{min} [kPa] (p1-p3)	4	4	5	6	7	8	8	9	10	11	11	12	12	13	15	17	18

VWPG51.15F1.2Q, VWPG51.15F1.2
1200 l/h nominal

\dot{V} [l/h]	/	37	268	327	383	438	493	556	619	704	811	919	1007	1096	1152	1176	1200
Scale	/	1.0	1.2	1.4	1.6	1.8	2.0	2.2	2.4	2.6	2.8	3.0	3.2	3.4	3.6	3.8	4.0
Δp_{min} [kPa] (p1-p3)	/	15	15	15	15	15	15	16	17	17	18	19	20	21	21	22	23

VWPG51.20F4.3Q, VWPG51.20F4.3
4250 l/h nominal

\dot{V} [l/h]	/	460	604	749	919	1114	1310	1540	1769	2029	2318	2608	3007	3406	3734	3992	4250
Scale	/	1.0	1.2	1.4	1.6	1.8	2.0	2.2	2.4	2.6	2.8	3.0	3.2	3.4	3.6	3.8	4.0
Δp_{min} [kPa] (p1-p3)	/	17	17	17	18	18	18	19	20	21	22	23	26	29	32	35	28

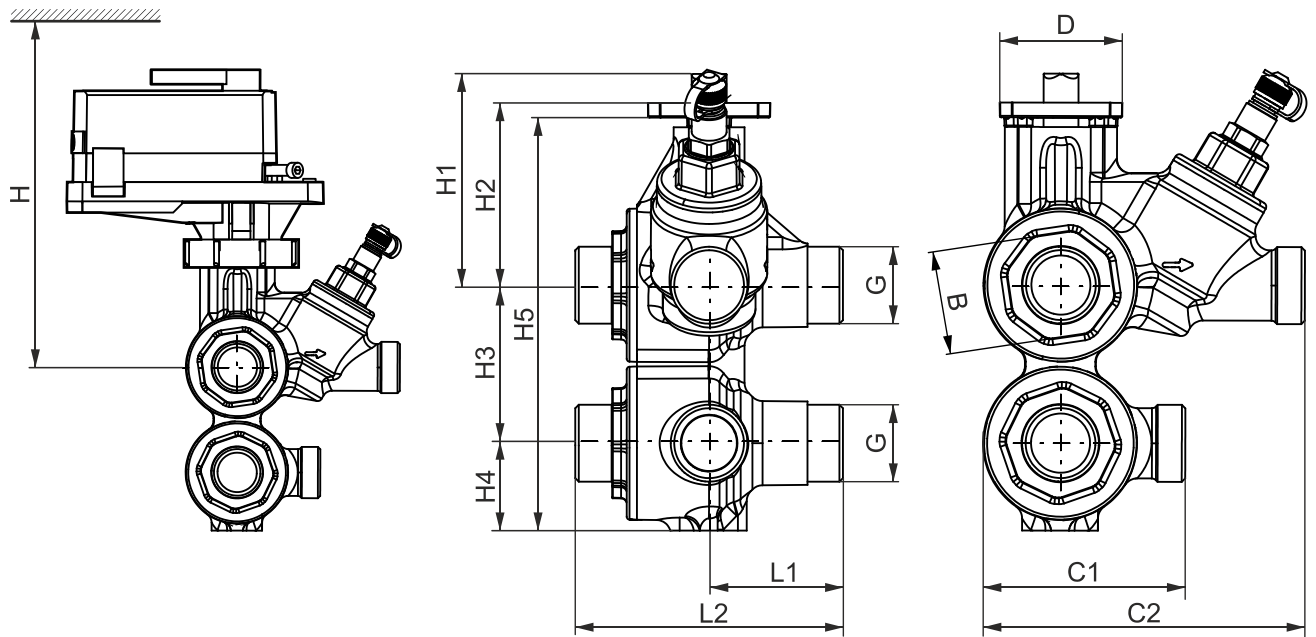

		DN	G	H	H1	H2	H3	H4	H5	L1	L2	B	C1	C2	D	
			[inch]	[mm]	[mm]	[mm]	[mm]	[mm]	[mm]	[mm]	[mm]	[mm]	[mm]	[mm]	[mm]	[kg]
VWPG51.15L0.9Q	S55264-V179	15	G ¾ "	>200	73	63	54	30	142	46	92	36	70	111	42	1.9
VWPG51.15L0.9	S55264-V180															1.7
VWPG51.15F1.2Q	S55264-V181															1.9
VWPG51.15F1.2	S55264-V182															1.7
VWPG51.20F4.3Q	S55264-V185	20	G 1 "	>230	80	70	69	38	172	55	110	50	84	154		3.4
VWPG51.20F4.3	S55264-V186															3.2

