

SIEMENS



TEC Controller

Unit Conditioner - Fan Coil Unit Cooling and Heating, Application 2051

Application Note

Table of Contents

- Overview4**
- Hardware Inputs5
- Hardware Outputs5
- Ordering Notes5
- Sequence of Operation6**
- Control Temperature Setpoints6
- Room Temperature and CTL TEMP7
- Day and Night Modes8
- Night Mode Override Switch8
- Heating/Cooling Switchover8
- Control Loops9
- Cooling Operation9
- Heating Operation9
- Fan Operation9
- Calibration10
- Fail Mode Operation10
- Application Notes10
- Wiring Diagram11
- Application 2051 Point Database12**

Overview

In Application 2051, the controller modulates separate valves in the fan coil unit for cooling and heating. The fan coil unit also has a fan to circulate room air. In order for the fan coil unit to work properly, the central plant must provide chilled and hot water.

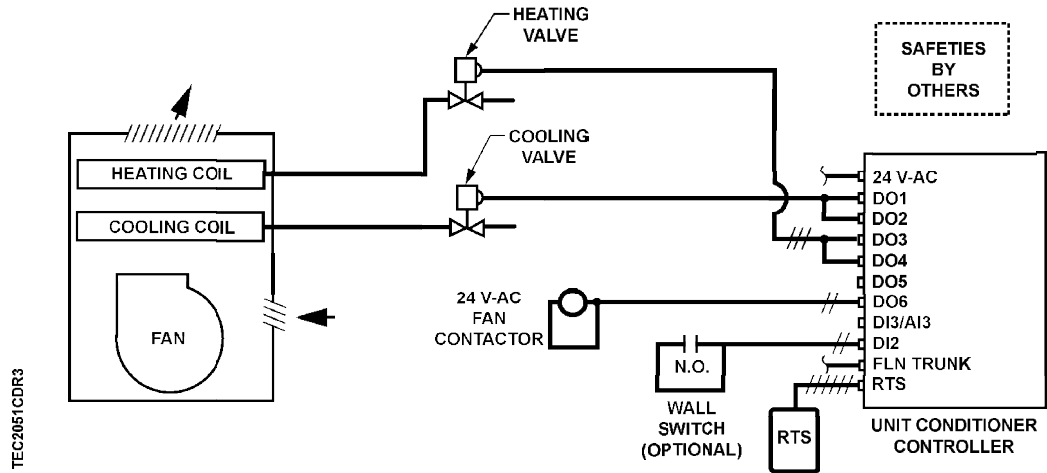

Application 2051 -- Fan Coil Unit Cooling and Heating Control Diagram.

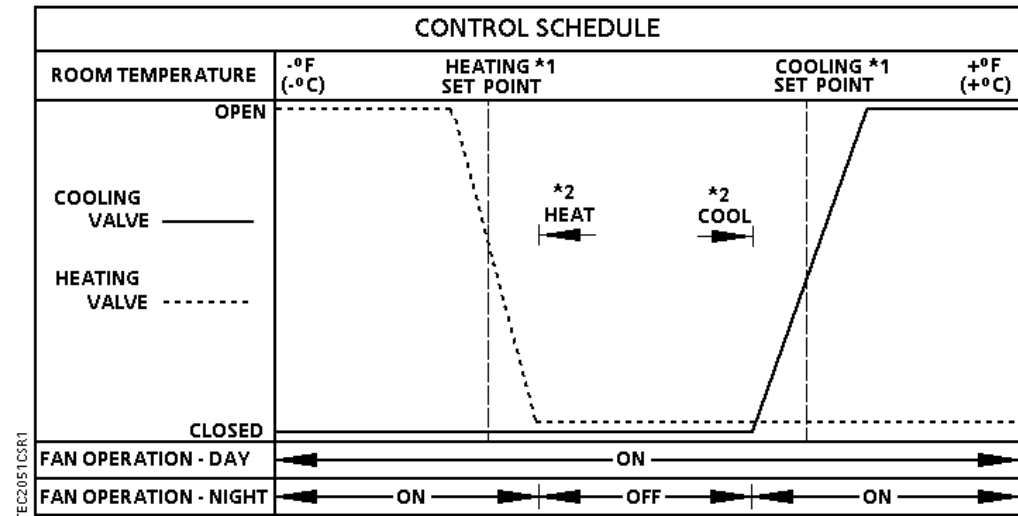

Application 2051 Control Schedule.



NOTES:

1. See *Control Temperature Setpoints*.
2. See *Heating/Cooling Switchover*.

Hardware Inputs

Analog

- Auxiliary temperature sensor (optional)
- Room temperature sensor
- Room temperature setpoint dial (optional)

Digital

- Night mode override (optional)
- Wall switch (optional)

Hardware Outputs

Analog

- None

Digital

- Fan (switched 24 Vac, pilot duty)
- Cooling valve actuator
- Heating valve actuator (floating control)

Ordering Notes

540-110N Siemens TEC Unit Conditioner Controller

Sequence of Operation

The following paragraphs present the sequence of operation for the Siemens TEC Unit Conditioner (Fan Coil) Controller.

Control Temperature Setpoints

This application has a number of different room temperature setpoints (DAY HTG STPT, NGT CLG STPT, RM STPT DIAL, etc.). The application actually controls using the CTL STPT. CTL STPT is set to different values depending on its override status, the time of day, whether or not a temperature deadband (zero energy band) has been configured, and the type of RTS used.

CTL STPT is Overridden:

If CTL STPT is overridden, that value is used regardless of any other settings. This disables the setpoint deadband feature.

CTL STPT in Night Mode:

The controller is in Night Mode if DAY.NGT = NGT and NGT OVRD = NGT.

When the controller is in night mode, CTL STPT holds the value of NGT CLG STPT or NGT HTG STPT depending on the value of HEAT.COOL. When the controller is in night mode the value of RM STPT DIAL is ignored.

CTL STPT in Day Mode:

The controller is in Day Mode if DAY.NGT = DAY or NGT OVRD = DAY.

Without setpoint dial:

When the controller is in day mode and STPT DIAL = NO, CTL STPT holds the value of DAY CLG STPT or DAY HTG STPT depending on the value of HEAT.COOL.

With setpoint dial:

When the controller is in day mode and STPT DIAL = YES, CTL STPT is set based on the value of the setpoint dial and the setpoint deadband.

The setpoint deadband exists to allow the controller to provide a separation of the heating and cooling temperature setpoints when a setpoint dial is enabled.

The setpoint deadband is the difference between the cooling and heating day setpoints (DAY CLG STPT - DAY HTG STPT). The setpoint deadband can be disabled by setting DAY HTG STPT equal to DAY CLG STPT. When DAY HTG STPT does not equal DAY CLG STPT, a setpoint deadband (or zero energy band) is used.

The following values are used in the calculation of CTL STPT:

- *Dial value* is the value of RM STPT DIAL limited between the value of RM STPT MIN and RM STPT MAX.
- *Deadband* is the value of the difference between DAY CLG STPT and DAY HTG STPT, half of which is applied to establish the current heating and cooling setpoints.
 - $Deadband = (DAY\ CLG\ STPT - DAY\ HTG\ STPT)$

CTL STPT is calculated as follows:

With Deadband Disabled:

CTL STPT = *Dial value*

With Deadband enabled in Heat Mode:

CTL STPT = *Dial value* - 0.5 * *Deadband* (limited between the value of RM STPT MIN and RM STPT MAX)

With Deadband enabled in Cool Mode:

CTL STPT = *Dial value* + 0.5 * *Deadband* (limited between the value of RM STPT MIN and RM STPT MAX).



NOTE:

If RM STPT DIAL is failed, it maintains the last known value.

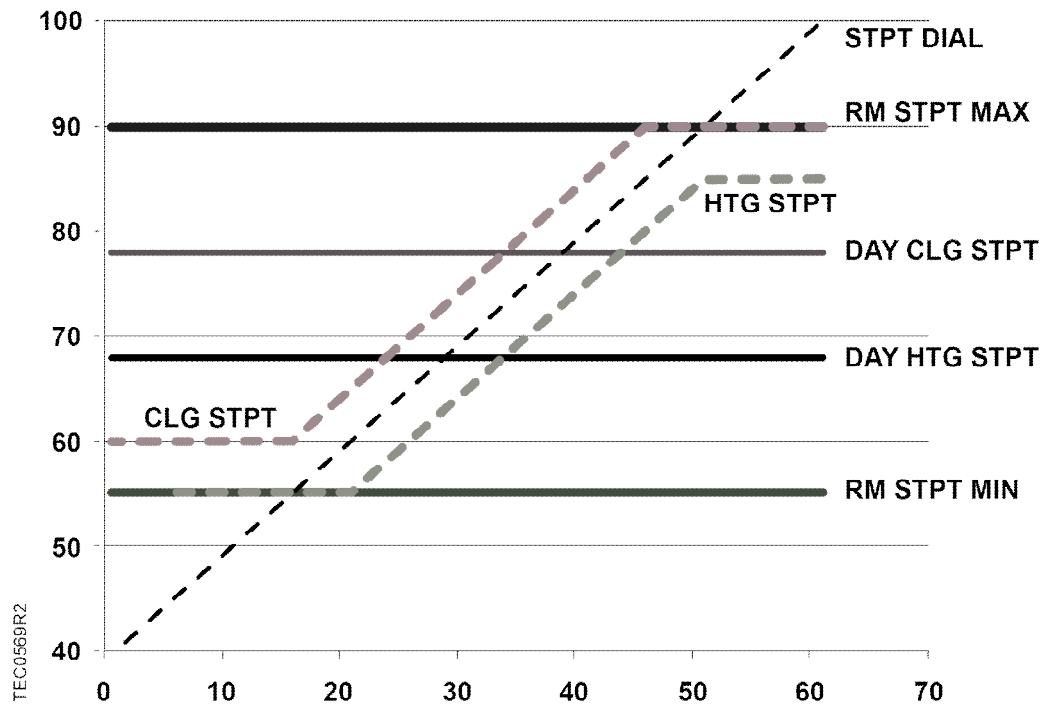

Room Temperature and CTL TEMP

ROOM TEMP is the temperature that is being sensed by the room temperature sensor (RTS).

CTL TEMP is the room temperature that is used for control purposes. In other words, what the application is trying to do is to maintain CTL TEMP at the control setpoint.

If CTL TEMP is overridden then:

- CTL TEMP equals its overridden value and ROOM TEMP has no effect on the value of CTL TEMP.

Day and Night Modes

The day/night status of the space is determined by the status of DAY.NGT. The control of this point differs depending on whether the controller is monitoring the status of a wall switch or if the controller is connected to a field panel.

When a wall switch is physically connected to the termination strip on the controller DI 2 (see the Control Diagram(s), and WALL SWITCH = YES, the controller monitors the status of DI 2.) When the status of DI 2 is ON (the switch is closed), then DAY.NGT will be set to DAY indicating that the controller is in day mode. When the status of DI 2 is OFF (the switch is open), then DAY.NGT will be set to NIGHT indicating that the controller is in night mode.

When WALL SWITCH = NO, the controller does not monitor the status of the wall switch, even if one is connected to it. In this case, if the controller is operating stand-alone, then the controller stays in day mode all the time. If the controller is operating with centralized control (that is, it is connected to a field panel), then the field panel can send an operator or PPCL command to override the status of DAY.NGT. See *Powers Process Control Language (PPCL) User's Manual (125-1896)* and *Field Panel User's Manual (125-3019)* or *BACnet Field Panel User's Manual (125-3020)* for more information.

Night Mode Override Switch

If an override switch is present on the room temperature sensor and a value (in hours) other than zero has been entered into OVRD TIME, pressing the override switch will reset the controller to DAY operational mode for the time period that is set in OVRD TIME. The status of NGT OVRD changes to DAY. After the override time elapses, the controller returns to night mode and the status of NGT OVRD changes back to NIGHT. The override switch on the room sensor will only affect the controller when it is in night mode.

Heating/Cooling Switchover

The heating/cooling switchover determines whether the controller is in heating or cooling mode by monitoring the room temperature and the demand for heating and cooling (as determined by the temperature control loops).

If the following conditions are met for the length of time set in SWITCH TIME, the controller switches from heating to cooling mode by setting HEAT.COOL to COOL:

- HTG LOOPOUT < SWITCH LIMIT.
- CTL TEMP > CTL STPT by at least the value set in SWITCH DBAND.
- CTL TEMP > the appropriate cooling setpoint minus SWITCH DBAND.

If the following conditions are met for the length of time set in SWITCH TIME, the controller switches from cooling to heating mode by setting HEAT.COOL to HEAT:

- CLG LOOPOUT < SWITCH LIMIT.
- CTL TEMP < CTL STPT by at least the value set SWITCH DBAND.
- CTL TEMP < the appropriate heating setpoint plus SWITCH DBAND.

Control Loops

The Siemens TEC Unit Conditioner (Fan Coil) Controller is controlled by two Proportional, Integral, and Derivative (PID) temperature loops.

The two temperature loops are a cooling loop and a heating loop. The active temperature loop maintains room temperature at the value in CTL STPT. See Control Temperature Setpoints [→ 6].

Cooling Operation

In cooling mode, the controller uses CTL STPT and CTL TEMP as inputs for the cooling loop.

The output of the cooling loop is CLG LOOPOUT, which modulates the cooling valve; VLV 1 COMD. HTG LOOPOUT is set to 0%.

When in heating mode, the cooling valve is closed.

Heating Operation

In heating mode, the controller uses CTL STPT and CTL TEMP as inputs for the heating loop.

The output of the heating loop is HTG LOOPOUT, which modulates the hot water valve, VLV 2 COMD, in order to warm up the space. CLG LOOPOUT is set to 0%.

When in cooling mode, the heating valve is closed.

Fan Operation



NOTE:

If this application is controlling a damper instead of a cooling valve, the fan operation is not applicable because there is no fan.

Day Mode – The fan may be set to stay ON at all times or to cycle to save energy. If CYCLE FAN = NO, the fan will be ON during the day. If CYCLE FAN = YES, the fan will cycle according to the following conditions:

1. If either VLV 1 COMD or VLV 2 COMD is open more than the value of STAGE FAN, the fan will turn ON.
2. If both valves are closed below the value of SWITCH LIMIT, the fan will turn OFF.
3. If neither of the above two conditions is met, the condition of the fan remains unchanged.

Night Mode – The fan cycles using the same three conditions described in the day mode section above, regardless of the setting of CYCLE FAN. If NGT OVRD = DAY (indicating that the night mode override button has been pressed), the fan is controlled as in day mode.

Calibration

During normal operation: To ensure that the damper and valves open and close fully, the controller will provide additional opening and closing time when commanded DMPR COMD or VLV 1 COMD and VLV 2 COMD = 100% and 0%.

The controller regularly calibrates the valve(s) based on the value of CAL TIMER. A value of 12 indicates that the controller will calibrate the valve(s) once every 12 hours.

The calibration consists of driving the valve(s) closed, and then resetting the value of VLV 1 POS to 0. If a second valve is used, VLV 2 POS is also set to 0. The actuators are then released to normal control.

Floating Control Actuation Auto-correct

In addition to the existing options for floating control actuator full stroke actions; all floating control actuators are provided with additional logic to fully drive open or closed when commanded to 100% or 0%.

Fail Mode Operation

If the room temperature sensor fails, the controller operates using the last known temperature value.

Application Notes

- If temperature swings in the room are excessive or there is trouble maintaining the setpoint, the cooling loop, the heating loop, or both need to be tuned.
- The controller as shipped from the factory keeps all associated equipment OFF. See the *Start-up Procedures* document for how to release the controller and its equipment to application control.
- Spare DOs can be used as auxiliary points that are controlled by the field panel after being defined in the field panel's database. If a cooling valve is not being controlled by the application, DO 1 and DO 2 may be used as auxiliary motor points. If a heating valve is not being controlled by the application, DO 3 and DO 4 may be used as auxiliary motor points. If using a pair of spare DOs to control a motor, you must make sure that the motor setup, motor timing, and motor rotation angle are enabled correctly before you unbundle VLV 1 COMD for DO 1 and DO 2 and VLV 2 COMD for DO 3 and DO 4. See the *Start-up Procedures* document on Asset Portal or InfoLink for more information.

For more information, contact your nearest Siemens Industry, Inc. representative.

Wiring Diagram



⚠ CAUTION

The controller's DOs control 24 Vac loads only. The maximum rating is 12 VA for each DO. An external interposing relay is required for any of the following:

- VA requirements higher than the maximum
- 110 or 220 Vac requirements
- DC power requirements
- Separate transformers used to power the load
(for example part number 540-147, Terminal Equipment Controller Relay Module)

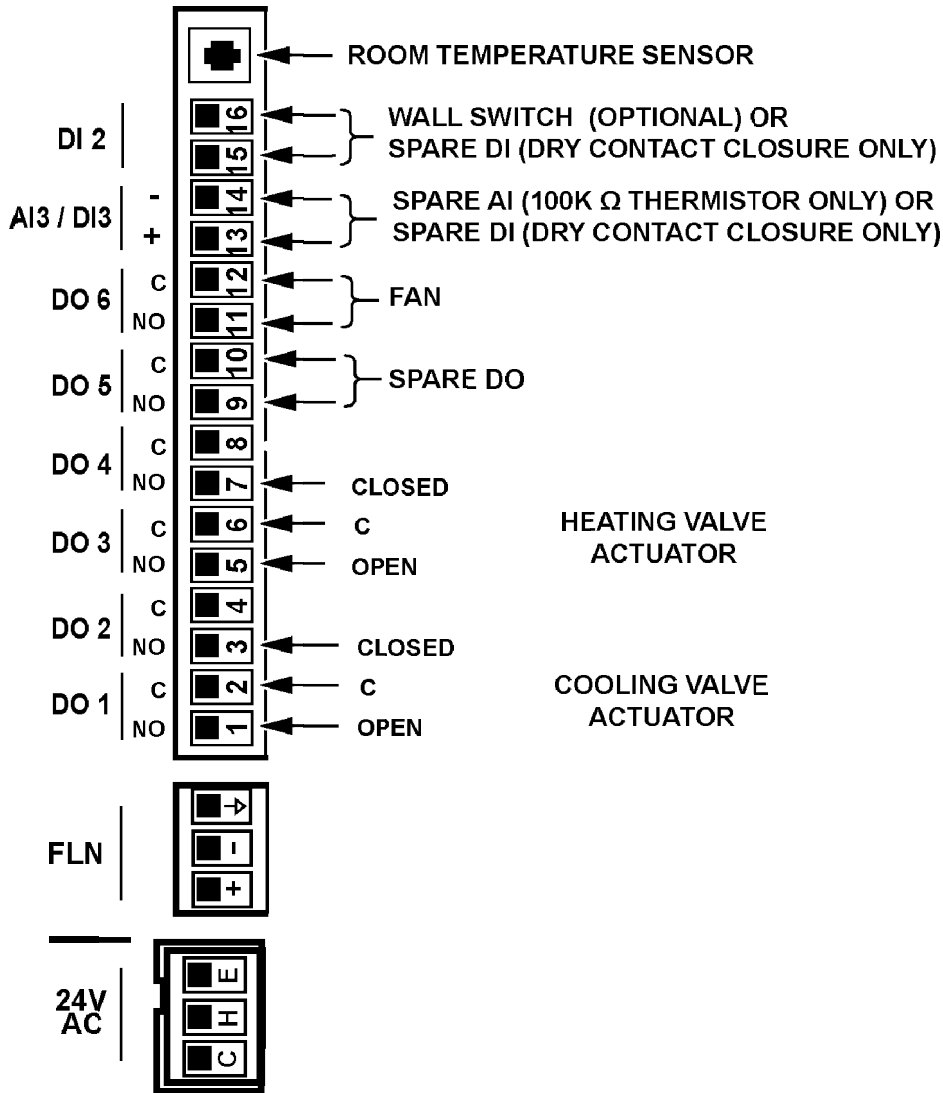

Application 2051 – Fan Coil Unit Cooling and Heating.

Application 2051 Point Database

Point Number	Descriptor	Factory Default (SI Units) ²⁾	Eng Units (SI Units)	Slope (SI Units)	Intercept (SI Units)	On Text	Off Text
1	CTLR ADDRESS	99	--	1	0	--	--
2	APPLICATION	2090	--	1	0	--	--
{04}	ROOM TEMP	74.0 (23.44888)	DEG F (DEG C)	0.25 (0.14)	48.0 (8.88888)	--	--
{05}	HEAT.COOL	COOL	--	--	--	HEAT	COOL
6	DAY CLG STPT	74.0 (23.44888)	DEG F (DEG C)	0.25 (0.14)	48.0 (8.88888)	--	--
7	DAY HTG STPT	70.0 (21.20888)	DEG F (DEG C)	0.25 (0.14)	48.0 (8.88888)	--	--
8	NGT CLG STPT	82.0 (27.92888)	DEG F (DEG C)	0.25 (0.14)	48.0 (8.88888)	--	--
9	NGT HTG STPT	65.0 (18.40888)	DEG F (DEG C)	0.25 (0.14)	48.0 (8.88888)	--	--
11	RM STPT MIN	55.0 (12.80888)	DEG F (DEG C)	0.25 (0.14)	48.0 (8.88888)	--	--
12	RM STPT MAX	90.0 (32.40888)	DEG F (DEG C)	0.25 (0.14)	48.0 (8.88888)	--	--
{13}	RM STPT DIAL	74.0 (23.44888)	DEG F (DEG C)	0.25 (0.14)	48.0 (8.88888)	--	--
14	STPT DIAL	NO	--	--	--	YES	NO
{15}	AUX TEMP	74.0 (23.495556)	DEG F (DEG C)	0.5 (0.28)	37.5 (3.055556)	--	--
18	WALL SWITCH	NO	--	--	--	YES	NO
{19}	DI OVRD SW	OFF	--	--	--	ON	OFF
20	OVRD TIME	0	HRS	1	0	--	--
{21}	NGT OVRD	NIGHT	--	--	--	NIGHT	DAY
{24}	DI 2	OFF	--	--	--	ON	OFF
{25}	DI 3	OFF	--	--	--	ON	OFF
{29}	DAY.NGT	DAY	--	--	--	NIGHT	DAY
{41}	DO 1	OFF	--	--	--	ON	OFF
{42}	DO 2	OFF	--	--	--	ON	OFF
{43}	DO 3	OFF	--	--	--	ON	OFF
{44}	DO 4	OFF	--	--	--	ON	OFF
{45}	DO 5	OFF	--	--	--	ON	OFF
{46}	FAN	OFF	--	--	--	ON	OFF
{48}	VLV 1 COMD	0	PCT	0.4	0	--	--
{49}	VLV 1 POS	0	PCT	0.4	0	--	--

Point Number	Descriptor	Factory Default (SI Units) ²⁾	Eng Units (SI Units)	Slope (SI Units)	Intercept (SI Units)	On Text	Off Text
51	MTR 1 TIMING	130	SEC	1	0	--	--
{52}	VLV 2 COMD	0	PCT	0.4	0	--	--
{53}	VLV 2 POS	0	PCT	0.4	0	--	--
55	MTR 2 TIMING	130	SEC	1	0	--	--
56	MTR1 ROT ANG	90	--	1	0	--	--
57	MTR2 ROT ANG	90	--	1	0	--	--
58	MTR SETUP	0	--	1	0	--	--
59	DO DIR. REV	0	--	1	0	--	--
60	CYCLE FAN	NO	--	--	--	YES	NO
63	CLG P GAIN	20.0 (36.0)	--	0.25 (0.45)	0	--	--
64	CLG I GAIN	0.01 (0.018)	--	0.001 (0.0018)	0	--	--
65	CLG D GAIN	0 (0.0)	--	2 (3.6)	0	--	--
66	CLG BIAS	0	PCT	0.4	0	--	--
67	HTG P GAIN	10.0 (18.0)	--	0.25 (0.45)	0	--	--
68	HTG I GAIN	0.01 (0.018)	--	0.001 (0.0018)	0	--	--
69	HTG D GAIN	0 (0.0)	--	2 (3.6)	0	--	--
70	HTG BIAS	0	PCT	0.4	0	--	--
{78}	CTL TEMP	74.0 (23.44888)	DEG F (DEG C)	0.25 (0.14)	48.0 (8.88888)	--	--
{79}	CLG LOOPOUT	0	PCT	0.4	0	--	--
{80}	HTG LOOPOUT	0	PCT	0.4	0	--	--
84	STAGE FAN	10	PCT	0.4	0	--	--
85	SWITCH LIMIT	5.2	PCT	0.4	0	--	--
86	SWITCH TIME	10	MIN	1	0	--	--
90	SWITCH DBAND	1.0 (0.56)	DEG F (DEG C)	0.25 (0.14)	0	--	--
{92}	CTL STPT	74.0 (23.44888)	DEG F (DEG C)	0.25 (0.14)	48.0 (8.88888)	--	--
96	CAL TIMER	12	HRS	1	0	--	--
98	LOOP TIME	5	SEC	1	0	--	--
{99}	ERROR STATUS	0	--	1	0	--	--

- 1) Points not listed are not used in this application.
- 2) A single value in a column means that the value is the same in English units and in SI units.
- 3) Point numbers that appear in brackets { } may be unbundled at the field panel.

Issued by
Siemens Industry, Inc.
Building Technologies Division
1000 Deerfield Pkwy
Buffalo Grove IL 60089
Tel. +1 847-215-1000

© 2014 Copyright Siemens Industry, Inc.
Technical specifications and availability subject to change without notice.