

## Room Temperature Sensors — Series 1000 4 to 20 mA

### Product Description

These Room Temperature Sensors work with any controller that accepts a 4 to 20 mA signal input. The sensors detect room temperature by means of a platinum sensing element and provide a 4 to 20 mA signal.

**NOTE:** These sensors can be mounted on electrical boxes, stud-type mounting brackets/plates, or drywall. Obtain the necessary mounting hardware and follow the appropriate mounting procedures for the type of installation required.

### Product Numbers

Table 1. Product Numbers.

Sensor Product Number*	Description
536-752	40°F to 90°F (4°C to 32°C)
536-753	20°F to 120°F (-7°C to 49°C)

\* Product number suffixes indicate the sensor color: A = desert beige; B = white. (Example: 536-752A for desert beige.)

### Required Tools

- Phillips size 1 or 2 screwdriver
- Medium flat-blade screwdriver
- Small flat-blade screwdriver
- 1/16-inch (1.5 mm) Allen wrench
- Calibration and Cover Screw Wrench Part Number 192-632 (pkg of 5)
- Medium duty electric drill
- Tape measure
- Marker or pencil
- 1-inch (25 mm) hole saw
- 3/16-inch (5 mm) drill bit

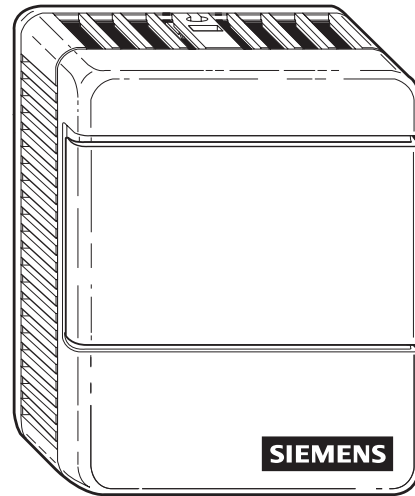

Figure 1. Room Temperature Sensor.

### Expected Installation Time

30 minutes

### Prerequisites

- Review Table 2 for appropriate mounting hardware.
- Install the appropriate field wiring (standard 4-conductor or 6-conductor room sensor cables, plenum or non-plenum as required), within the maximum wiring run length for the individual field panel or equipment controller.

**NOTE:** All wiring must comply with National Electric Code (NEC) and local regulations.

### Warning/Caution Notations

<b>WARNING:</b>		Personal injury, or loss of life may occur if you do not follow the procedures as specified.
<b>CAUTION:</b>		Equipment damage, or loss of data may occur if you do not follow the procedures as specified.

## Mounting Location

Keep the sensor vertical.

Locate the sensor:

- According to design specifications and local regulations.
- Allowing the air to circulate around it freely (not in recessed areas or behind doors).
- Allowing a minimum of 4 inches (100 mm) free space above and below for proper airflow, for the front cover removal tool, and the computer communication cable.

- Away from drafts caused by doors, windows, outside walls, air registers, pipes, return air plenums, etc.
- Away from heat sources such as strong lights, fireplaces, direct sunlight, etc.
- On an inside wall about 5 feet (1.5 m) above the finished floor.

**NOTE:** While not recommended, if you need to mount the sensor on exterior brick or cement-type walls, see Table 2, Accessories.

## Accessories

**NOTE:** For retrofit installations, normally follow the method used by the previous device. You may need to replace existing mounting hardware in order to mount the sensor vertically.

**Table 2. Accessories.**

Part Number*	Description	Used For	Reference
182-621	Gym guard kit, desert beige	Gyms and similar environments requiring a guard (incompatible with adapter bases and the extender ring).	TB 193
182-621E	Gym guard kit, satin chrome	See <i>Part Number 182-621</i> .	TB 193
182-683	Metal (and wood) stud mounting bracket (pkg of 5)	Single sensor rough-in installations. Kit includes a locator.	129-057
182-685	Spring clips: finished drywall mounting kit (pkg of 10)	Drywall mounting.	129-073
192-506	Electrical box adapter plate assembly kit (pkg of 5)	Electrical boxes mounted flush with the wall and for gyms and similar environments requiring a guard. See also <i>Part Number 544-782</i> .	Figure 7
192-860	Finish plate Kit 1 gang, 1 sensor, stainless steel	Single sensor low cost mounting. Plate is 3.7 x 5.1-inches (.5 x 12.9 cm)	TB 238
536-666	Mounting strap	Used with standard light switch plate (field supplied) to mount a 2 x 4 box.	540-040, 540-237
544-782*	Single adapter base mounting kit	4 x 4 boxes and all single sensor installations on walls with over-sized holes, paint lines etc, that need covering, and on exterior brick, cement type walls. Adapter base is 3-1/2 x 5 inches (8.8 x 12.7 cm). Kit includes electrical box adapter plate assembly, Part Number 192-495.	Figure 3
544-783*	Double adapter base mounting kit	4 x 6 and all double sensor installations on walls with over-sized holes, paint lines, etc, that need covering, and on exterior brick, cement type walls. Adapter base is 5 x 7 inches (12.7 x 18 cm). Kit includes electrical box adapter plate assembly, Part Number 192-720.	Figure 3
544-784	Non-conduit rough-in kit, double	Double sensor non-conduit rough-in installations. Kit includes a locator.	540-784
544-785*	Extender ring kit	Exterior brick/cement-type walls; fits to the back of sensor base plate.	—
544-800	Universal adapter kit	Retrofitting a previous horizontal installation to a vertical one, or when the screw spacing does not fit the electrical box adapter plate. Kit includes a multi-slotted adapter plate.	Figure 3
981-344	Electrical box cover plate kit	2 x 4 box rough-ins. Kit includes a locator and connector.	—
—	Various finish plates	Double sensor low-cost mounting for a variety of applications.	TB 238

\* Product number suffixes indicate color: A = desert beige; B = white (Example: 544-782B for white.)

## Installation

### Typical drywall mounting (no rough-in)

1. Mark the center (cable) hole and mounting hole locations using the sensor base plate as a template. See Figure 2.

**CAUTION:**  
 Use only the top and bottom holes.

2. Drill two 3/16-inch (4.8 mm) mounting holes.
3. Cut a 1-inch (25 mm) center hole with a hole saw.
4. If using screws to attach the sensor, insert two plastic wall anchors.
5. Pull at least 3 inches (75 mm) of the cable through the mounting hardware in the order shown in Figure 2.

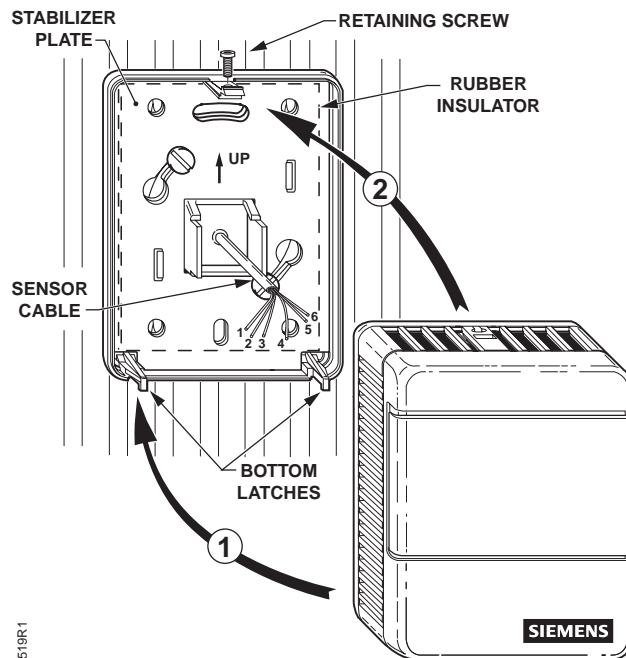

**Figure 2. Drywall Mounting (No Rough-in).**

6. Mount the sensor base plate on the wall noting the UP arrow on the stabilizer plate.
  - a. Install either the two mounting screws provided, the drive rivets provided, or spring clips, but do not tighten.

**CAUTION:**  
 Pounding too hard or over tightening may cause the sensor base plate to crack or bend.

- b. Level the sensor base plate for appearance.
  - c. Tighten the two mounting screws to the sensor base plate.
7. Cut the cable jacket leaving about 3 inches (75 mm) of cable wire on the sensor side of the drywall.

**CAUTION:**  
 For retrofit installations:  
 Before cutting the cable, make sure it is disconnected from the controller.

8. Unplug the terminal block from the back of the printed circuit board and terminate the cable wires at the sensor terminal block. See Figure 3 for sensor terminal block, Figure 5 for MBC/RBC, and Figure 6 for MEC.
9. Reinstall the terminal block.
10. Feed the extra cable back through the hole in the rubber insulator.
11. Snap the sensors front to the sensor base plate in this order:
  - a. Hook the sensor front to the bottom latches.
  - b. Push the top of the sensor front cover into place until it latches.
12. Tighten the sensor front retaining screw. See Figure 2.
13. Terminate the other end of the wires at the appropriate controller. See Figure 5 for MBC/RBC, and Figure 6 for MEC.

The installation is now complete.

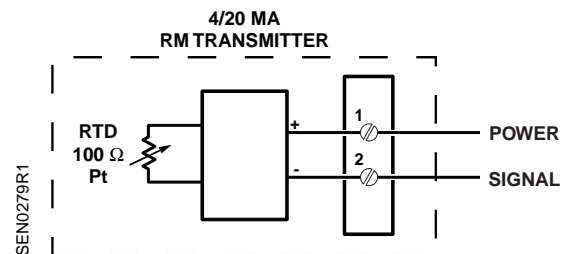

**Figure 3. Sensor Terminal Block Wiring.**

### Typical electrical box and rough-in mounting

1. If a locator is attached to the rough-in device, remove the locator by removing the two screws and lightly rocking the locator to pull it free.
2. Untie the twist tie and pull about 3 inches (75 mm) of the sensor cable into the space.
3. If you have a single-sensor electrical box, install the electrical box adapter plate. See Figure 4.

If you have a double-sensor electrical box, install the required mounting plates(s).

If you use a universal adapter kit for a retrofit job, install the multi-slotted plate in place of the electrical box adapter plate. See Figure 4.

4. Pull the cable through the required mounting hardware in the order shown in Figure 4.
5. Install the two sensor mounting screws provided but do not tighten.
6. Mount the sensor base plate on the wall, noting the UP arrow on the stabilizer plate.
7. Level the sensor base plate for appearance.
8. Tighten the two mounting screws to the sensor base plate.



**CAUTION:**

Over-tightening may cause the sensor base plate to crack or bend.

9. Continue with Steps 7 through 13 of *Typical Drywall Mounting (no rough-in)*.

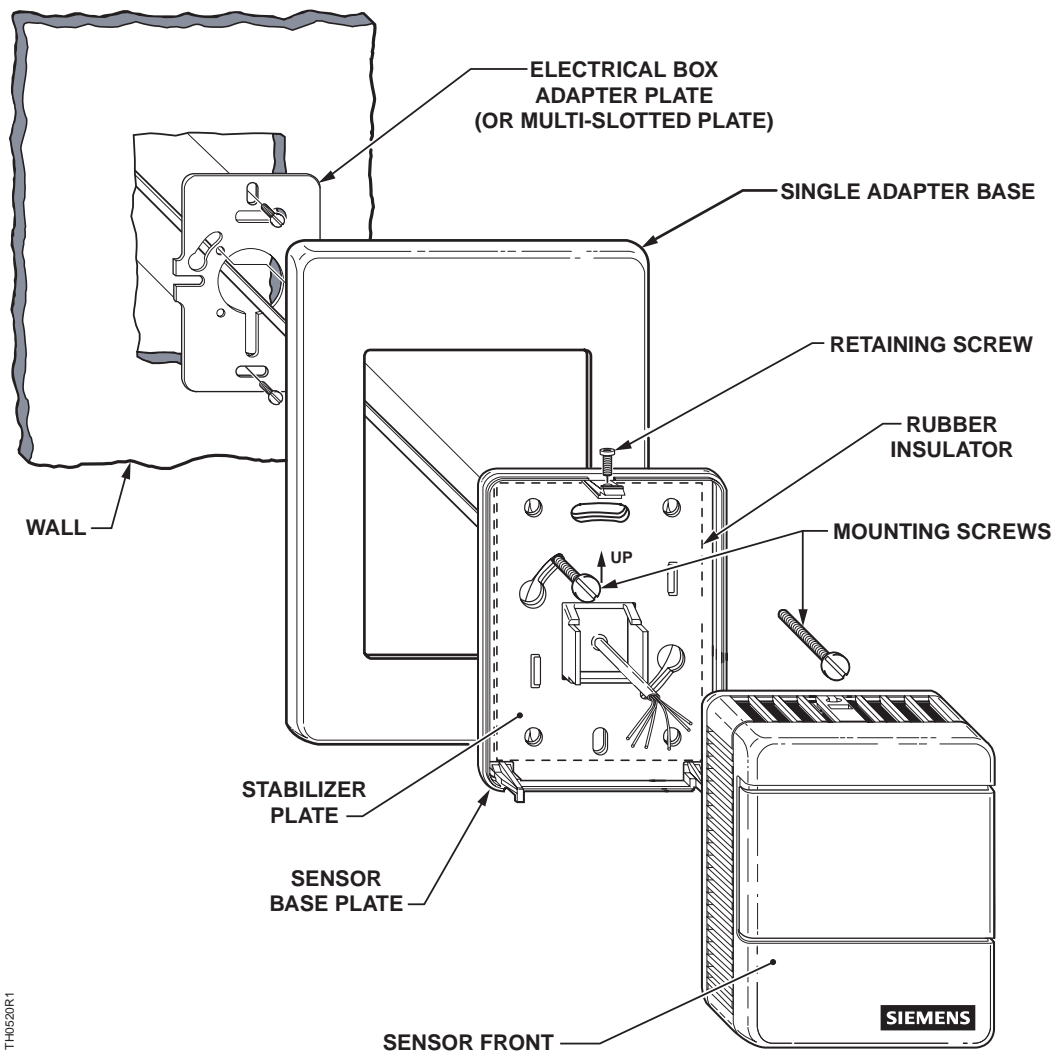

Figure 4. Electrical Box and Rough-in Mounting.

## Terminating the cable wires

**NOTE:** All connections for one sensor must be terminated in the same field panel whether MBC or MEC.

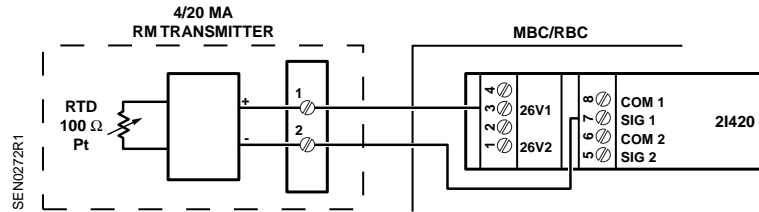

Figure 5. MBC/RBC Wiring Example.

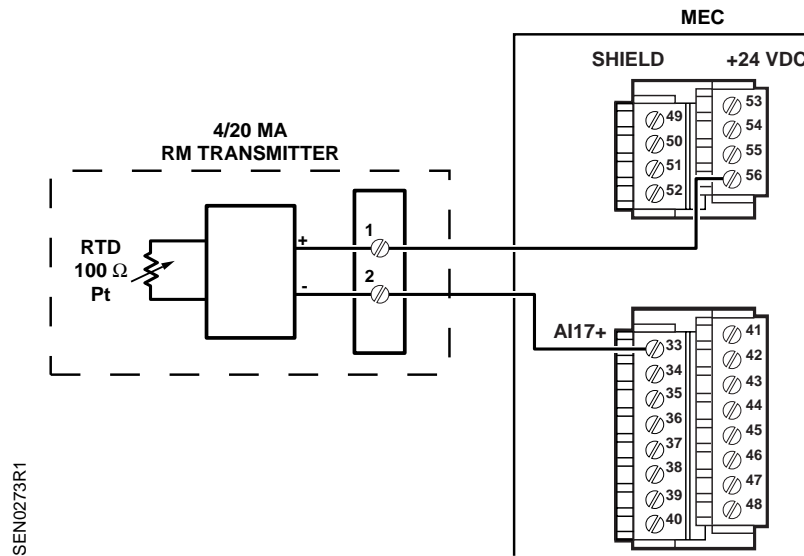

Figure 6. MEC Wiring Example.

Information in this publication is based on current specifications. The company reserves the right to make changes in specifications and models as design improvements are introduced. Product or company names mentioned herein may be the trademarks of their respective owners. © 2012 Siemens Industry, Inc.