

KNX

KNX room units and sensors, wall-mount

QMX6.P30, QMX6.P34, QMX6.P40, QMX6.P44, QMX6.P70, QMX6.P74



The QMX6 product family consists of room units/sensors with KNX communication that operate in the following ecosystems:

- Desigo™ (PL-Link): when commissioned using the Siemens ABT tool
- KNX (S-Mode): when commissioned using the KNX Association's ETS tool

Functions in all ecosystems:

- Sensors for temperature, relative humidity and CO2 (depending on the variant)
- Air quality indicator (P70 and P74)
- LCD touch display for HVAC and Green Leaf (P34, P44 and P74)
- Room operating modes: Auto, comfort, pre-comfort (standby), economy and protection

Additional functions in KNX ecosystem (S-mode):

- Temperature controller for HVAC water applications: Radiators, floor heating, radiant (chilled/heated) ceilings
- Relative humidity controller
- CO2 controller
- Setpoint operation from display: for room temperature, relative humidity and CO2

Type overview

	QMX6. P30	QMX6. P34	QMX6. P40	QMX6. P44	QMX6. P70	QMX6. P74
	QMX6. P30-BK	QMX6. P34-BK	QMX6. P40-BK	QMX6. P44-BK	QMX6. P70-BK	QMX6. P74-BK
Order number (MLFB)	S55720-S604-A	S55720-S607-A	S55720-S605-A	S55720-S608-A	S55720-S606-A	S55720-S609-A
	S55720-S642-A	S55720-S645-A	S55720-S643-A	S55720-S646-A	S55720-S644-A	S55720-S647-A
Touch LCD user interface (display and operation for HVAC)		•		•		•
Green Leaf (display and operation)		•		•		•
Air quality indicator					•	•
Temperature sensor	•	•	•	•	•	•
Relative humidity sensor			•	•	•	•
CO2 sensor					•	•

Accessories

	QMX6.MP-W	QMX6.MP-B
Order number (MLFB)	S55720-S659-A	S55720-S660-A
Description	Replacement mounting plate, white	Replacement mounting plate, black

Functions in Desigo ecosystem (PL-Link)

- QMX6 room unit/sensor is connected to an automation station and acts a peripheral room device
- QMX6 does not perform control functions
- HVAC applications are defined by the automation station
- QMX6 room unit/sensor is normally combined with automation stations to control the following HVAC applications:
 - **DXR2/PXC3 room automation station:**
 - Variable Air Volume (VAV)
 - Fan Coil Unit (FCU)
 - Radiant (Heated/chilled) ceiling
 - Radiator
 - Heat pump
 - Dual duct
 - **PXC4/5/7 primary automation station:**
 - Air Handling Unit (AHU)
 - **DXR1.E10PL-112 and DXR1.E10PL-113 room automation station**
 - Variable Air Volume (VAV)
 - Fan Powered Box (FPB)

Functions in KNX ecosystem (S-mode)

In the KNX ecosystem (S-Mode), the QMX6 room unit/sensor:

- performs control functions. The QMX6 must be linked to another KNX actuator, to release the outputs and control the HVAC equipment
- is designed to control water-based HVAC equipment and applications:

HVAC equipment	Mode	
	Heating	Cooling
Radiator	Yes	No
Radiant ceiling	Yes (Heated ceiling)	Yes (Chilled ceiling)
Floor heating/cooling	Yes (floor heating)	Yes (floor cooling)

HVAC application	Mode	Control application
2-pipe water system	Heating or cooling	2-point (on/off) control PWM Continuous (0...100%)
2-pipe/2-stage water system	Heating or cooling	
	Stage 1	PWM Continuous (0...100%)
	Stage 2	PWM Continuous (0...100%)
2-pipe water system with changeover (changeover is done via a KNX object)	Heating or cooling (on same pipes)	2-point (on/off) control PWM Continuous (0...100%)
2-pipe/2-stage water system with changeover (changeover is done via a KNX object)	Heating or cooling (on same pipes)	
	Stage 1	PWM Continuous (0...100%)
	Stage 2	PWM Continuous (0...100%)
4-pipe water system	Heating	2-point (on/off) control PWM Continuous (0...100%)
	Cooling	2-point (on/off) control PWM Continuous (0...100%)
4-pipe/2-stage water system	Heating	
	Stage 1	PWM Continuous (0...100%)
	Stage 2	PWM Continuous (0...100%)
	Cooling	
	Stage 1	PWM Continuous (0...100%)
	Stage 2	PWM Continuous (0...100%)

Temperature sensor and controller (valid for all variants)

This device measures the temperature and provides room-based temperature control for heating and/or cooling. The room temperature controller sends a control value to the KNX valve actuator.

This value is calculated using a control algorithm (2-point control, steady PI control, or steady PI control with sequence control) based on the actual room temperature that is measured and the setpoint. This valve actuator controls the flow rate of hot and cold water and thus also the change in room temperature.

Humidity sensors (valid for P40, P44, P70 and P74) and Humidity controller (valid for all variants)

The device variants P40, P44, P70 and P74 can measure relative humidity. All device variants have a humidity controller that can be used as a staged controller or steady PI controller. As the devices P30 and P34 do not have an integrated humidity sensor, they can only use an external humidity sensor value for the controller. The other device variants (P40, P44, P70 and P74) can use internal as well as external humidity sensor values.

Up to 5 control signal stages can be selected for staged control. For PI control, the value output can be either switching (1-bit) or steady (8-bit).

CO2 sensor (valid for P70 and P74) and CO2 controller (valid for all variants)

The device variants P70, and P74 can measure the CO2 content in the air. All device variants have an air quality controller that can be used as a staged controller or steady PI controller. As the devices P30 and P34 do not have an integrated air quality sensor, they can only use an external air quality sensor value for the controller. The other device variants (P70 and P74) can use internal as well as external air quality sensor values.

Up to 5 control signal stages can be selected for staged control. For PI control, the value output can be either switching (1-bit) or steady (8-bit).

Air quality indicator (valid for P70, P74)

The air quality indicator shows the CO2 content by changing the LED color as follows:

- Red = bad air quality
- Orange = fair air quality
- Green = good air quality

The limit values for the LED can be configured in the ETS.

Green Leaf (valid for P34, P44 and P74)

The Green Leaf function is used to set a temperature setpoint range in the ETS in order to improve energy efficiency. The LED of the Green Leaf push-button in the top right corner of the device is used to display the status:

- If the setpoint is within the preset limit range in the ETS, the LED lights up green.
- If the setpoint is outside the limit value range preset in the ETS, the LED lights up red.

If the LED lights up red, you can return to the preset value in energy-efficient range by pressing the Green Leaf push-button.

Calculator (valid for all variants)

Up to 3 independent calculators with up to 6 inputs each are available. Percentage values, temperature values, illuminance, humidity values and CO2 concentration can be selected as inputs. These values can be evaluated in terms of maximum value, minimum value or weighted value.

Comparator (valid for all variants)

The value comparator can be used to compare two similar analog values (e.g., temperature) with each other.

Manager/subordinate operation (valid for P34, P44 and P74)

In the ETS, the device can be set to act as a manager or subordinate. The manager serves as the primary control and regulation device as well as a display and control device. The subordinate operates as a pure display and operation device.

Manager/subordinate operation is especially useful in large rooms in which more than one room unit is installed. The function allows the user to change the temperature setpoint, room operating mode, fan speed etc. from any room device. The changed settings are then mirrored to all room units. Each room can contain only one manager and one or more subordinates. It is possible to use the manager to read out the current room temperature from the subordinate room units in order to ensure a consistent temperature in larger rooms or spaces. However, this setting is not implemented in manager/subordinate operation; instead, it has to be set using the “source of temperature value” parameter in the “temperature control” parameter card.

User interface

Overview

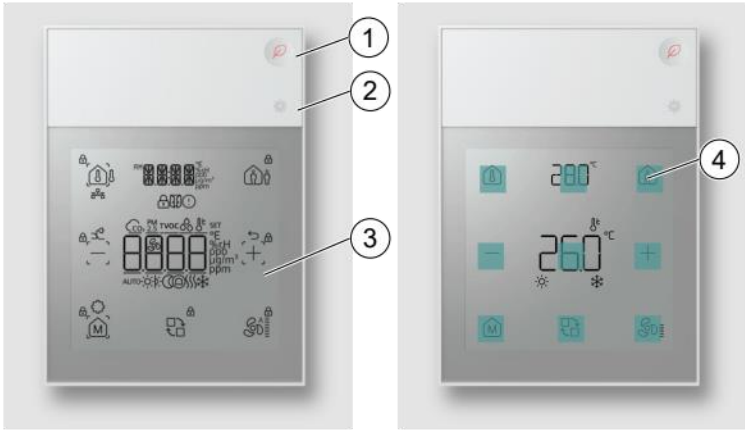









Fig. 1: General overview from the front













1	Green Leaf
2	Air quality indicator
3	User interface
4	Touch points









Symbols/buttons



Fig. 2: Button page

Symbol	Description	Function
	Room operating modes	Operation
AUTO	Automatic operation	Display
	Comfort mode	Display
	Pre-comfort (standby) mode	Display
	Economy mode	Display
	Protection mode	Display
	Sensor switch	Operation
	Temperature	Display

Symbol	Description	Function
	Relative humidity	Display
	CO2	Display
	Fan	Operation and display
	Decrease setpoint	Operation
	Increase setpoint	Operation
	Heating	Display
	Cooling	Display
SET	Indicates that the setpoint is shown on the display.	Display
°C	Degrees Celsius	Display
°F	Degrees Fahrenheit	Display
% r.h.	% relative humidity	Display
ppm	Particles per million (CO2)	Display
	Room measurement	Operation and display
	Outside measurement	Operation and display
	Presence	Operation and display
	Absence	Operation and display
	Operation lock (for the complete user interface)	Display
	Window contact open	Display

Symbol	Description	Function
	Operational lock (for individual buttons)	Display
	Air quality indicator inactive	Inactive
	Air quality indicator active - bad air quality	Display
	Air quality indicator active - fair air quality	Display
	Air quality indicator active - good air quality	Display
	Green Leaf display inactive	Inactive
	Green Leaf display active - energy-efficient range	Operation and display
	Green Leaf display active - non-energy-efficient range	Operation and display

KNX PL-Link configuration

Automatic (plug & play) commissioning

If only one QMX6 is connected to an automation station that uses a tool that was configured with the correct QMX6 model. In this case the QMX6 device is automatically assigned to the automation station, and the pair is fully functional.

Alternatively, automatic commissioning is also possible for more than one QMX6 device if their serial numbers are manually entered in the tool.

Manual commissioning - QMX6 with display (P34, P44, P74)

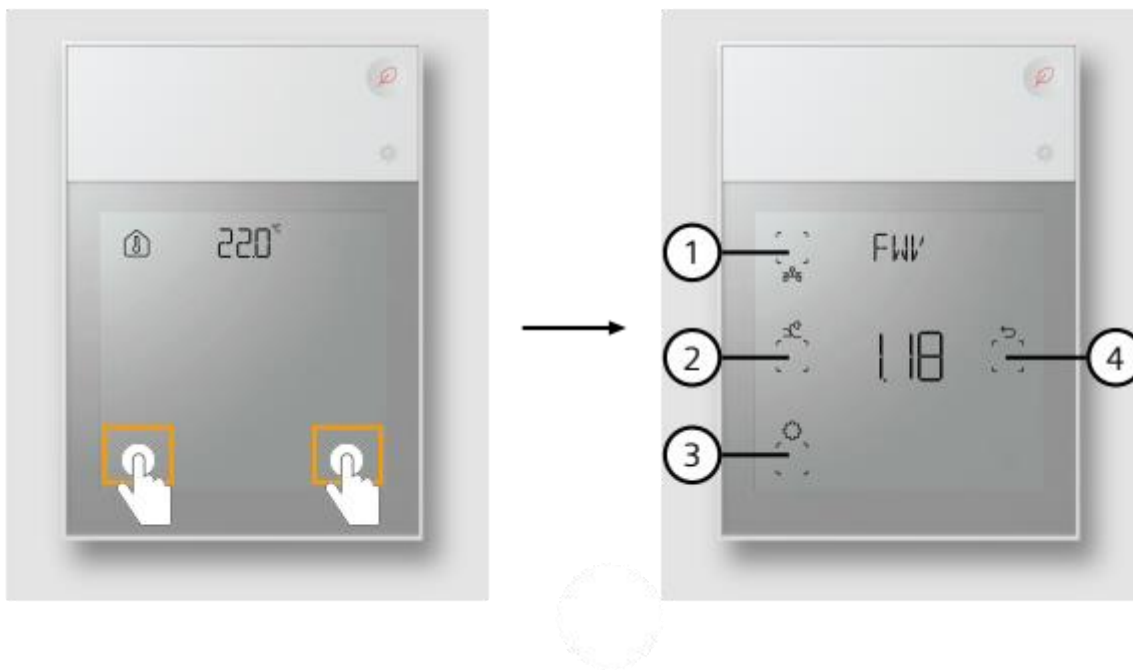

Fig. 3: Manual commissioning on the display

Position	Symbol	Description	Function
1		Programming mode	Operation
2		Factory reset	Operation
3		Connection test	Operation
4		Exit	Operation

Addressing and connection test

1. To enter engineering mode, press any touch point to wake up the screen, then simultaneously press the areas shown above (left) for at least 5 seconds.
2. The display should now show the firmware version number and the PL-Link commissioning buttons.
3. Press the Programming Mode button [1] to assign the QMX6 to the automation station. The display shows "EnAB".
4. Press the Connection Test button [2] to check if the assigning was successful. The display shows "donE" or "FAIL", depending on the result. If it shows "FAIL", repeat Step 3 again.

Factory reset

1. Press the Factory Reset button [3] for at least 5 seconds to restore the QMX6 device state to the factory default. The display shows "RST".
2. Disconnect the KNX bus between the QMX6 and automation station, if you want to keep the device in factory default state.
3. Keep the KNX cable connected if you want to automatically re-assign your devices.

NOTICE	
!	This operation resets all user preference data and configuration settings to factory default. This operation is irreversible.

Manual commissioning - QMX6 without display (P30, P40, P70)*

Addressing and connection test

1. Short press (<2 s) the programming pin on the back of the device to assign the QMX6 to the automation station. The LED remains on.
2. After commissioning is completed, the device will restart and the LED will automatically turn off.
3. Medium press (>2 s and <20 s) the programming pin to perform a connection test to check if the assigning was successful. The LED flashes.
4. The result takes around 10 seconds. If the test is successful, the LED stops flashing. If not, the LED continues to flash. To stop the LED from flashing, short press (<2 s) the programming pin.

Factory reset

- 1, Press the programming pin for at least 20 seconds then release. The device is locked and restarts within 10 seconds.
2. Disconnect the KNX bus between the QMX6 and automation station, if you want to keep the device in factory default state.
3. Keep the KNX cable connected if you want to automatically re-assign your devices.

*also possible for QMX6 with display (P34, P44, P74)



NOTICE	
!	This operation resets all user preference data and configuration settings to factory default. This operation is irreversible.

Notes

Security

 CAUTION	
	<p>National safety regulations</p> <p>Failure to comply with national safety regulations may result in personal injury and property damage.</p> <ul style="list-style-type: none">• Observe national regulations and comply with the appropriate safety regulations.

Disposal

 	<p>The device is considered an electronic device for disposal in accordance with European Directive and may not be disposed of as domestic waste.</p> <ul style="list-style-type: none">• Use only designated channels for disposing the devices.• Comply with all local and currently applicable laws and regulations.
--	--



If a device is defective, contact the local sales office.

Technical data

Power data

	QMX6. P30	QMX6. P34	QMX6. P40	QMX6. P44	QMX6. P70	QMX6. P74
KNX bus voltage	DC 24 V (DC 21...30 V)					
KNX bus current (max.)	7.5 mA at DC 24 V	7.5 mA at DC 24 V	7.5 mA at DC 24 V	10 mA at DC 24 V	15 mA at DC 24 V	15 mA at DC 24 V
KNX power consumption (max.)	0.18 W	0.18 W	0.18 W	0.24 W	0.36 W	0.36 W

Operating data

Temperature sensor

Valid for all variants	
Measuring element	NTC resistance sensor
Measuring range	0 °C ... 50 °C (32 °F... 122 °F)
Measuring accuracy	20 °C ... 25 °C (68 °F...77 °F): ± 0.2 K (typical) 15 °C ... 35 °C (59 °F...95 °F): ± 0.4 K (typical) 5 °C ... 50 °C (41 °F...122 °F): ± 0.7 K (typical)

Humidity sensor

	QMX6.P40	QMX6.P44	QMX6.P70	QMX6.P74
Measuring element	digital capacitive relative humidity sensor			
Measuring range	0...100 % r.h. (non-condensing)			
Measuring accuracy	40 % r.h...60 % r.h.: ± 2 % at 23 °C (73 °F) (typical) 5 % r.h...95 % r.h.: ± 5 % at 23 °C (73 °F) (typical)			

CO2 sensor

	QMX6.P70	QMX6.P74
Measuring element	NDIR CO2 sensor with automatic baseline calibration	
Measuring range	400 ppm...10000 ppm	

	QMX6.P70	QMX6.P74
Measuring accuracy at 25 °C and 1013 hPa	400 ppm...2000 ppm: ± (50 ppm + 2 % of measured value) 2000 ppm...5000 ppm: ± (50 ppm + 3 % of measured value) > 5000 pm: decreased accuracy	
Pressure dependency	1.6% of reading per kPa	
Lifetime	>15 years	

Automatic baseline calibration (ABC) of CO2 sensor

The baseline value for the ABC function of the CO2 sensor is 400 ppm (fresh air). Therefore, for the ABC function to function properly, the room/space must have intermittent occupancy (i.e. not be constantly occupied), and be supplied with fresh air (400 ppm) at least once a week, as the sensor's calibration cycle is 180 hours (7.5 days).

Mechanical data

	QMX6. P30 QMX6. P30-BK	QMX6. P34 QMX6. P34-BK	QMX6. P40 QMX6. P40-BK	QMX6. P44 QMX6. P44-BK	QMX6. P70 QMX6. P70-BK	QMX6. P74 QMX6. P74-BK
Housing material	Plastic	Plastic	Plastic	Plastic	Plastic	Plastic
Dimensions	see Dimension drawing [▶ 18]	see Dimension drawing [▶ 18]	see Dimension drawing [▶ 18]	see Dimension drawing [▶ 18]	see Dimension drawing [▶ 18]	see Dimension drawing [▶ 18]
Product weight	118.4 g	146.5 g	118.4 g	146.5 g	125, 3 g	154.7 g
Color	white (similar to RAL9010) black (similar to RAL9005)	white (similar to RAL9010) black (similar to RAL9005)	white (similar to RAL9010) black (similar to RAL9005)	white (similar to RAL9010) black (similar to RAL9005)	white (similar to RAL9010) black (similar to RAL9005)	white (similar to RAL9010) black (similar to RAL9005)

Environmental conditions

Valid for all variants	Operation	Storage/Transport
Ambient temperature	0 °C...+50 °C (32 °F...122 °F)	-25 °C...+70 °C (-13 °F...158 °F)
Relative humidity (non-condensing)	≤ 85% r.h.	≤ 95% r.h.
Environmental rating	Class 3K5	Class 2K3
Mechanical conditions	1M11	2M4

Protection classifications, standards and certifications

Valid for all variants	
Degree of pollution (according to IEC 60664-1)	2
Over-voltage category (according to IEC 60664-1)	I
Housing protection class (according to EN 60529)	IP30
Electrical safety, bus (SELV)	Yes

Valid for all variants

EMC requirements, device complies with	EN 60730-1 EN IEC 63044-5-1 EN IEC 63044-5-2 EN IEC 63044-5-3
Certification logos	CE, UKCA, WEEE, UL916 logo and category (93189,CA/US), CSA, ICES, RCM, EAC, KNX
Class according to FCC and ICES-03 (Canada)	Class B

Dimension drawing

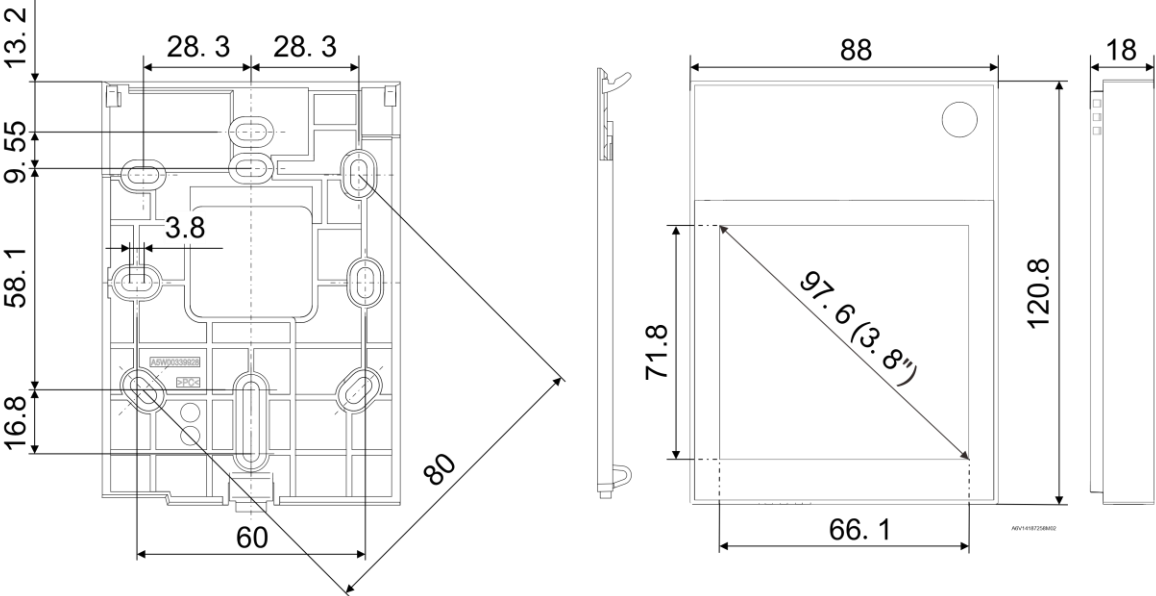

Fig. 4: Dimension drawing

Product documentation and support

Product documentation

Documents related to the product, for example the operating/assembly manual, technical product information, application program description, product database, additional software and CE declarations, can be downloaded from the following website:

<https://knx-td.sihub.siemens.com>

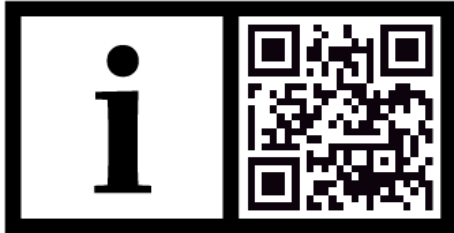

Frequently asked questions

For frequently asked questions regarding the product and their solutions, see:

[Link](#)



Support

Contact details for additional questions relating to the product:

Tel.: +49 89 9221-8000

<http://www.siemens.com/supportrequest>



Issued by
Siemens Industry, Inc.
Smart Infrastructure
1000 Deerfield Pkwy
Buffalo Grove IL 60089
+1 847-215-1000

© Siemens 2024-2026
Technical specifications and availability subject to change without notice.