

Systems Integration

Insight[®] OPC Client

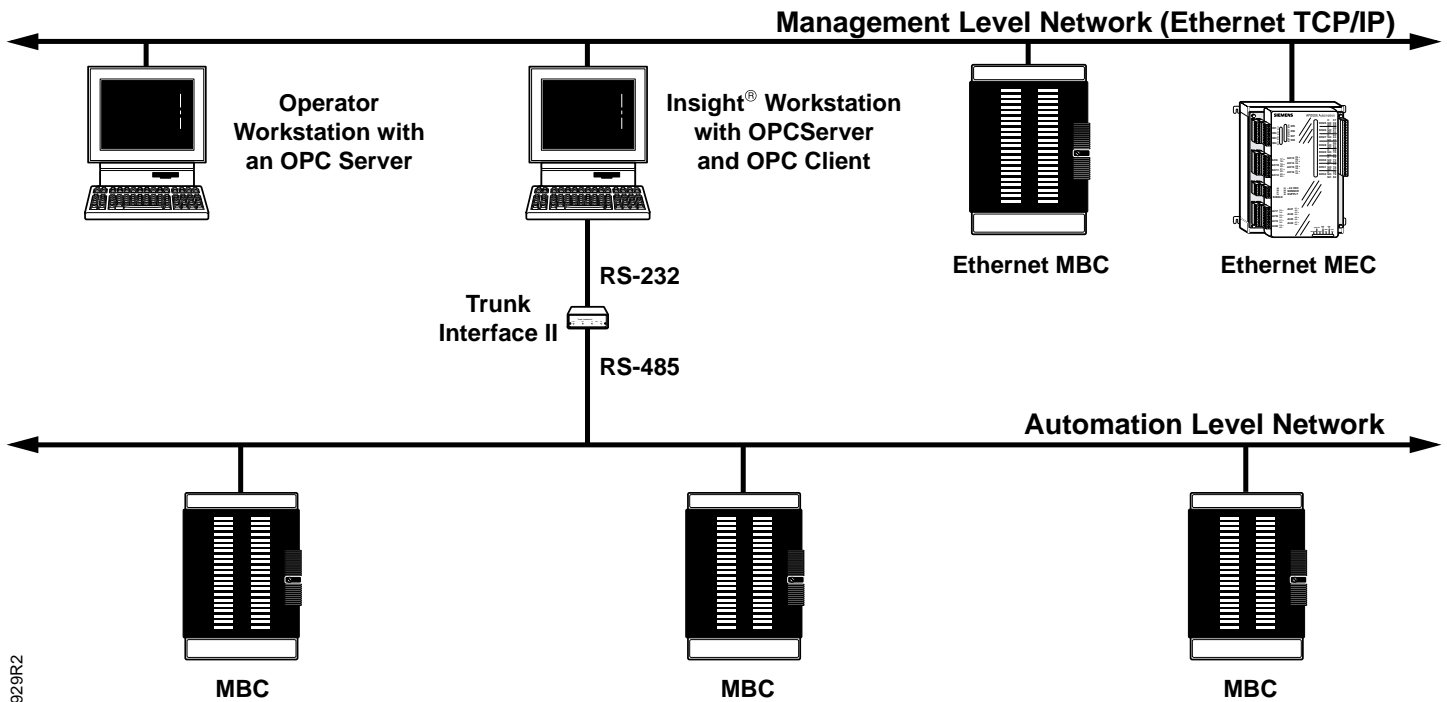

GW0929R2

Figure 1. System Architecture.

Notes on System Architecture

The architecture for the Windows® XP/2000/2003 Server integration using OPC consists of an Insight® workstation with OPC Client and an OPC server residing in a third-party operator workstation. Communication between OPC server and OPC Client workstations is via Ethernet TCP/IP. Between the Insight workstation and the Automation Level Network, a Trunk Interface II is required to convert from RS-232 to RS-485.

Functionality

The Insight OPC Client and OPCServer translate and communicate data between the APOGEE® Automation System and a third-party operator workstation supporting an OPC server. Through the Insight OPC Client, the operator can monitor the current value of third-party system points, obtain point information and point characteristics, and command the point values. As a practical limit, the OPC Client can command and monitor up to 1000 defined APOGEE points.

Keys to Success

A good working relationship with the local third-party operator workstation field office or representative is vital to project success. In addition, a thorough understanding of the Windows XP/2000/2003 Server environment is necessary for effective implementation and maintenance.

Benefits

Software-based integration using OPC brings powerful process control, power monitoring, and business software together with the building control capabilities of the

APOGEE Automation System. Bringing the third-party control and monitoring information into the Insight workstation allows process control, power monitoring, and business software, together with building control systems, to operate with a single user interface. This provides marked advantages in reduced operating costs, reduced training and increased employee productivity, as well as powerful systems information, reporting, and control.

System Compatibility

The Insight OPC Client and OPCServer perform the systems communication function. Communication between the third-party workstation and the APOGEE Automation System is made possible through the OPC standard.

Products Supported

Windows XP/2000/2003 Server software packages with OPC server software are supported. Testing is required to guarantee system compatibility.

Ordering Information

Description	Product Number
Insight OPC Client Option	By Quote Only
Insight OPCServer 1000 Point Option	571-162
Insight OPCServer 5000 Point Option	571-163

For more information, see www.sbt.siemens.com.

Information in this document is based on specifications believed correct at the time of publication. The right is reserved to make changes as design improvements are introduced. Product or company names mentioned herein may be the trademarks of their respective owners.
© 2006 Siemens Building Technologies, Inc.