

FC2005/FC901

System installation instruction

Wiring diagram

Software clearance declaration











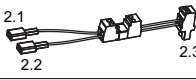
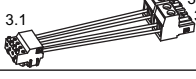

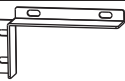
FC901

FC2005

FC2005/FC901 installation instruction

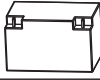
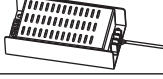
• Accessories and separate parts

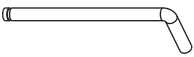
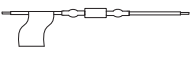
| Accessory items | Content | Installation instruction | Qty |
|-----------------|---|--|-----|
| 1 |  | Cable between batteries, refer to figure 1 | 1 |
| 2 |  | Cable between batteries and main board, refer to figure 1,figure 2 | 1 |
| 3 |  | Cable between City tie board and main board, refer to figure 2 | 1 |
| 4 |  | Earth cable between enclosure and main board, refer to figure 1 and figure 2 | 1 |
| 5 |  | Grounding cable for front door and power supply, refer to figure 1 | 2 |
| 6 |  | Battery bracket left, refer to figure 1 | 1 |
| 7 |  | Battery bracket right, refer to figure 1 | 1 |
| 8 |  | Cable ties | 10 |
| 9 |  | No.8 screws, refer to figure 1 | 12 |
| 10 |  | No.4 screws, refer to figure 2 | 2 |
| 11 |  | Spacer for City tie board, refer to figure 2 | 2 |
| 12 |  | Power supply MOV(Metal Oxide Varistor), refer to figure 2 | 1 |
| S1 |  | Battery cell, refer to figure 1 | 2 |
| S2 |  | Power supply, refer to power supply installation instruction sheet delivered with power supply | 1 |
| S3 |  | Front door hinge axis lock pin, refer to Detail A | 2 |
| S4 |  | Front door hinge axis, refer to Detail A | 2 |
| S5 |  | EOL for NAC, refer to Detail C | 2 |

Note: Item 3,6,7,11,S1and S2 are not delivered with the FC901 and FC2005.And should be ordered separately.

• Assembling notes

1. Mount the batteries with battery brackets.
2. Mount the power supply MOV, then mount the power supply to the enclosure.
3. Mount the City tie module onto the main board according to the Figure 2 (City tie module is optional).
4. Connect the cables to the corresponding position marked on the drawing
(The power supply input cable and output cable are not included in the FC901 and FC2005 package).
4. Tie the cables to the enclosure with cable tie, refer to the Figure 1(Cable tie features).
5. Mount the Main board assembly onto the Enclosure according to Figure 3.
6. Mount the Lock pin to the Front door axis(Both are included in the Enclosure package)

FC2005/FC901 installation instruction

- Battery, Power supply and City tie PCB assembly installation instruction

 Pay attention to the battery polarity at 2.1 and 2.2

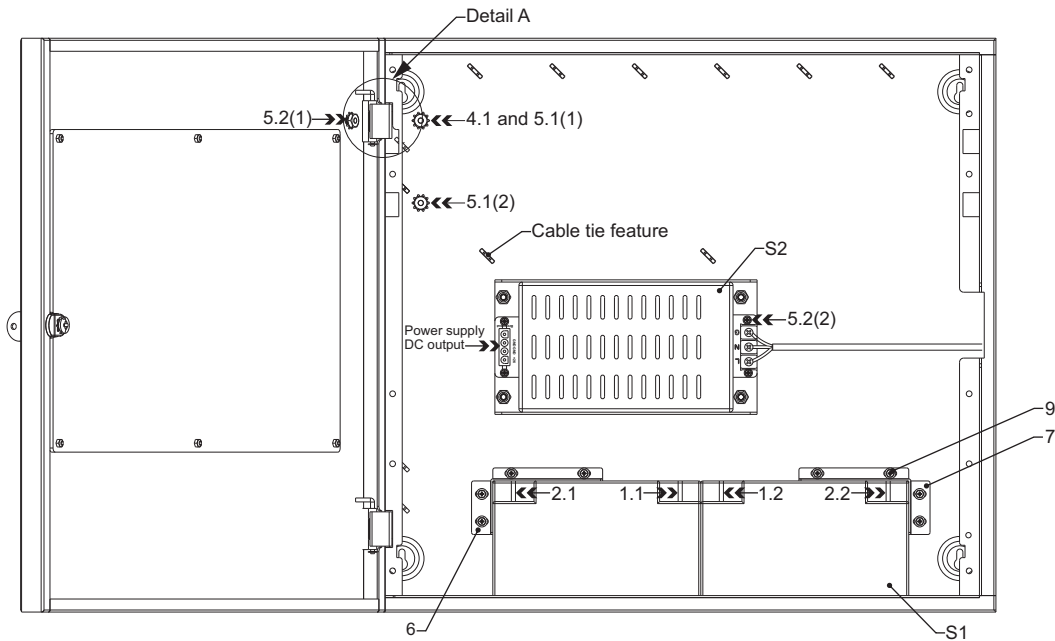
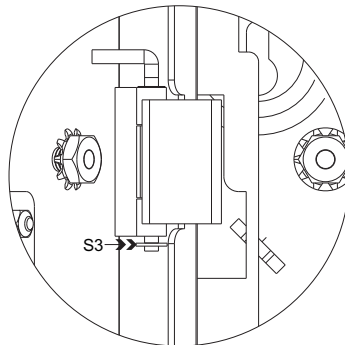

Figure 1 Installation instruction(Front view with front door open)



Detail A Front door hinge and lock pin installation instruction

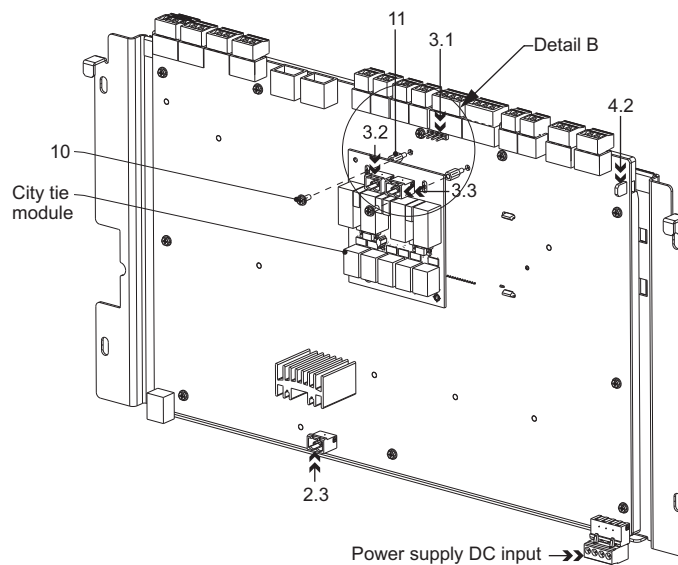

Figure 2 Installation instruction(Main board assembly back view)

FC2005/FC901 installation instruction

- City tie cable, Main board and EOL installation instruction

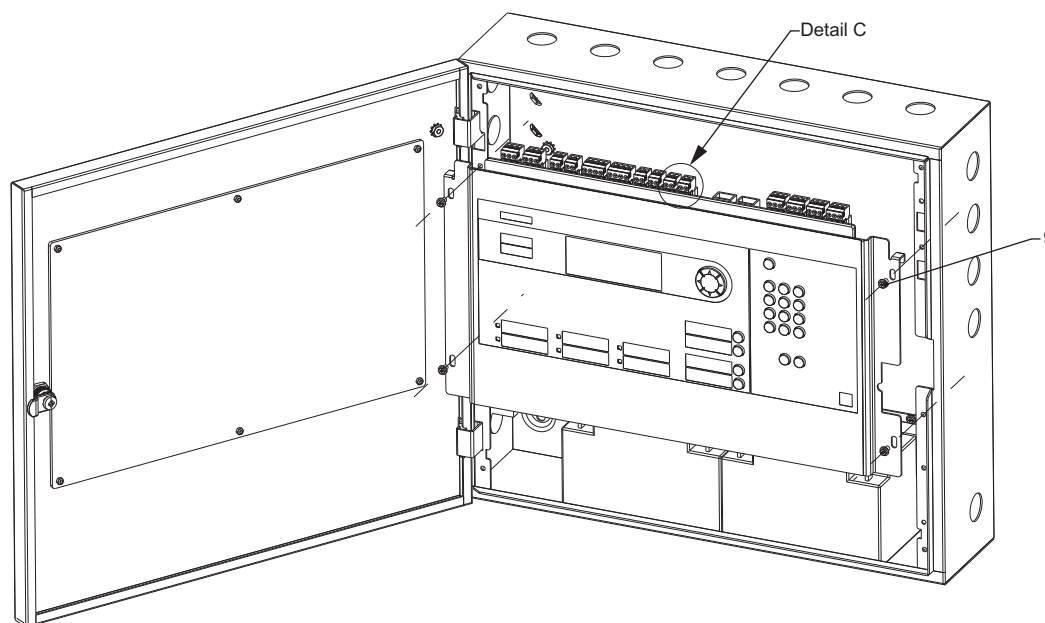
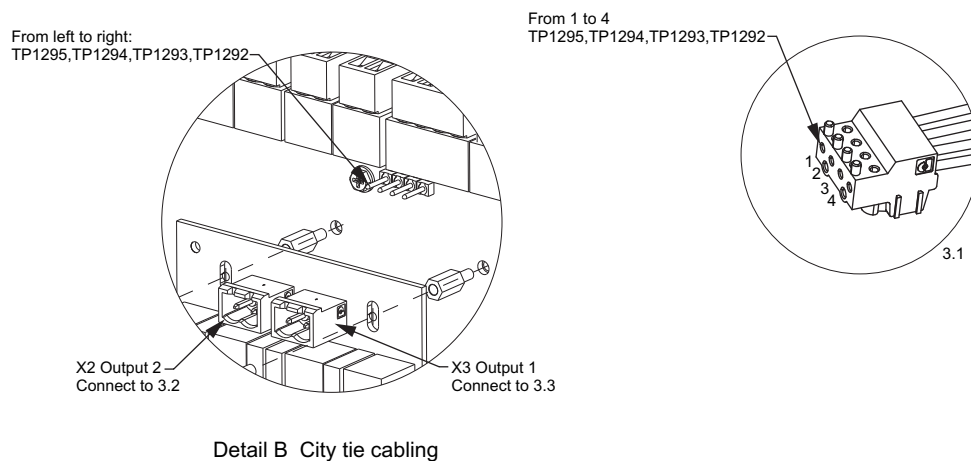
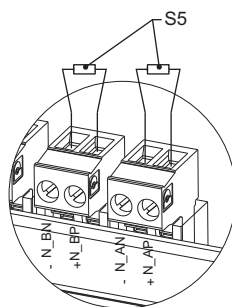

Figure 3 Main board assembly installation instruction



Detail C NAC EOL installation instruction

FC2005/FC901 installation instruction

- Power supply MOV(Metal Oxide Varistor) Installation instruction

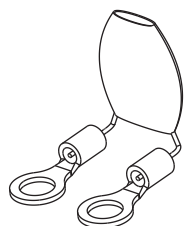

Step 1: Bend the MOV connector pin refer to the picture for an example

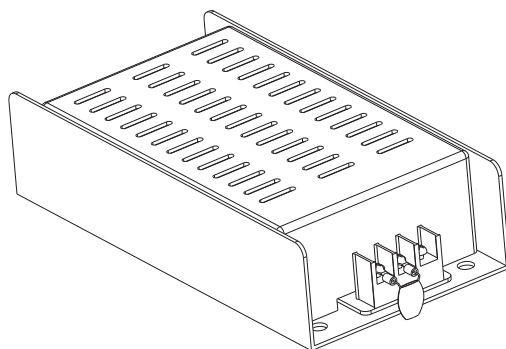

Step 2: Fix or weld the MOV onto the power input connector. Take the picture as reference

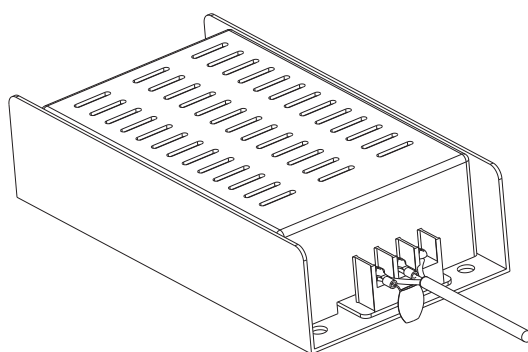

Step 3: Fix the AC input cable and screws on the connector. Take the picture as reference

FC2005/FC901 installation instruction

- Installation instruction without Trim kit

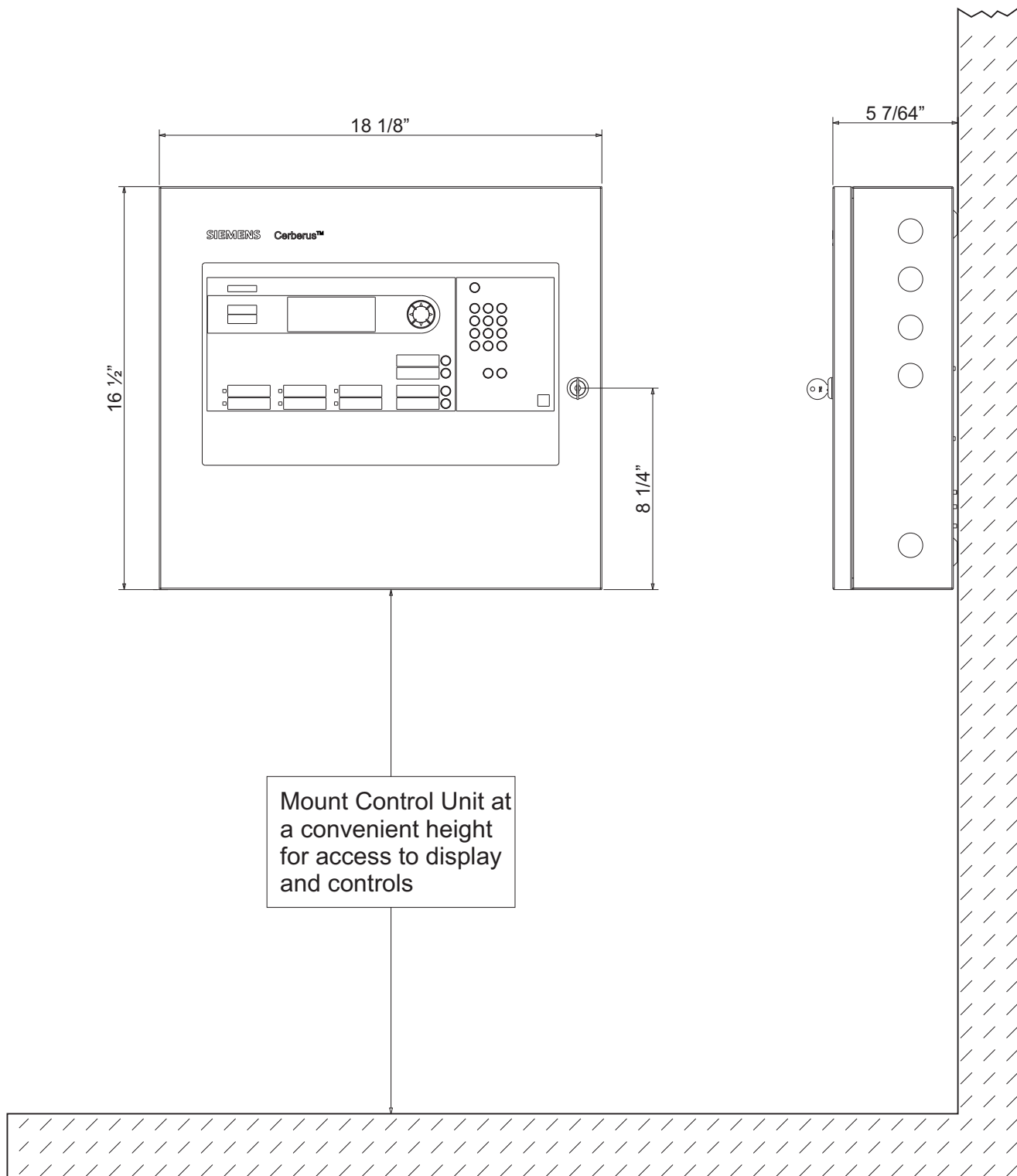

FC2005/FC901 installation instruction

- Installation instruction with Trim kit

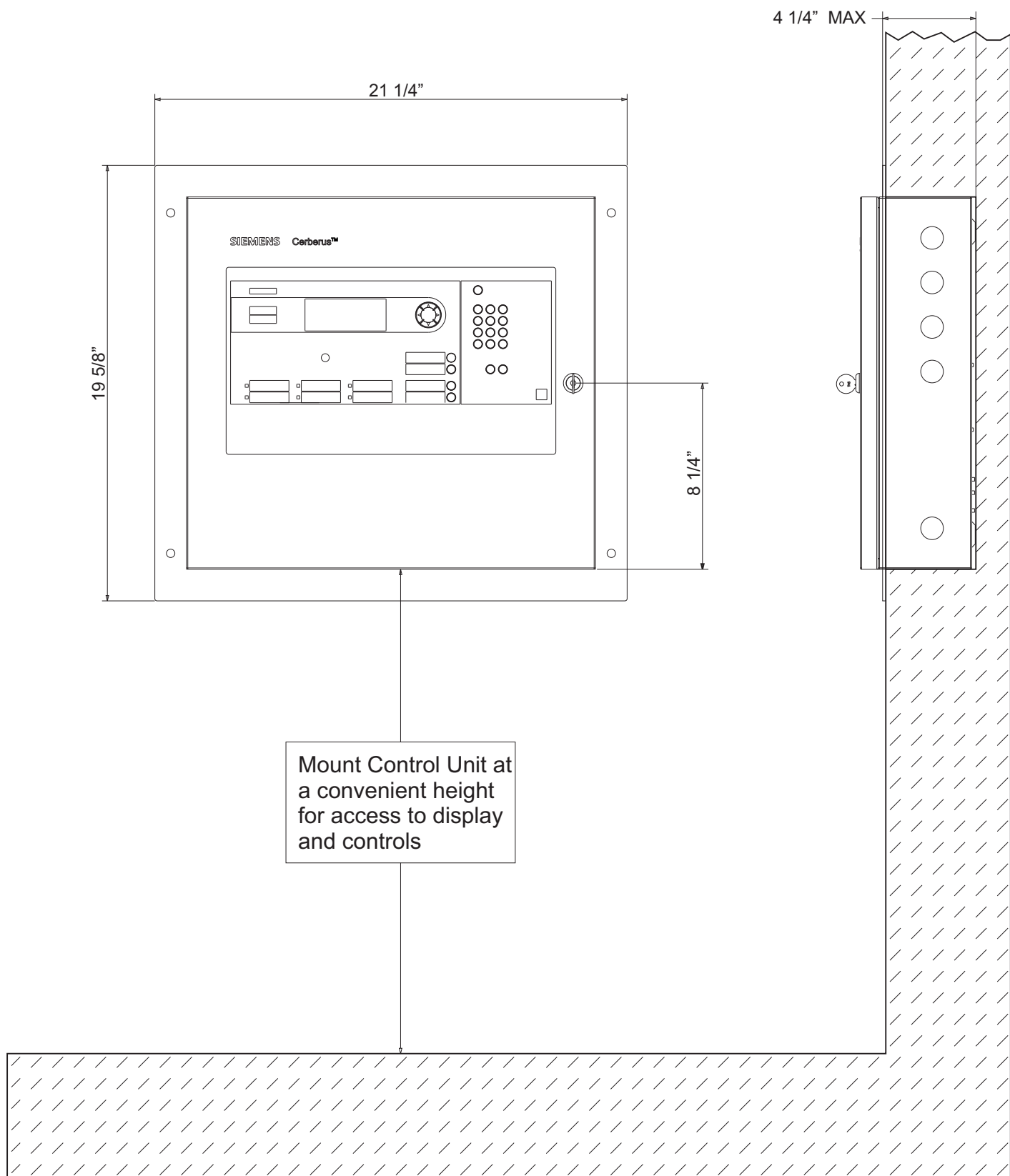

FC2005/FC901 SYSTEM CONNECTION DIAGRAM

• FC2005/FC901 SYSTEM GENERAL SPECIFICATION

Environmental

Operating temperature - 32 - 120°F (0 - 49°C)
 Relative humidity - Up to 93% @ 90°F (32°C)
 To be installed in a indoor dry protected environment only

Primary Power Supply

Input: 120VAC, 60 Hz or 220 VAC, 50 Hz
 @ 2.0A Max.
 Supervised
 Output: 26VDC @ 6.5A Max.
 Max current: 6.5A (2 hours Max.)
 Filtered and Regulated

Secondary Power Supply

24V lead-acid battery set
 Max. charged voltage: 27.8 VDC
 Automatic low battery disconnect voltage: 19.2±0.1VDC
 Max. charge current: 0.45A
 Battery capacity: 12AH to 18AH
 Supervised

Auxiliary Power Outputs

- Non-resettable power output

Power limited
 Alarm status: 0.75A
 Normal stand by: 0.05A
 Voltage: 19 to 28VDC
 Ripple: 0.1 VAC
 Special Application

- Resettable power output

Power limited
 Alarm status: 0.75A
 Normal stand by: 0.05A
 Voltage: 19 to 28VDC
 Ripple: 0.1 VAC
 Special Application

Status Relays

Non-power limited
 One programmable relay
 Three non-programmable relays: Trouble, Supervisory, Alarm
 Contact rating: 2A, 30VDC maximum
 Form C contact
 Notification Appliance Circuits

Power limited

Supervised

| Current Draw | Maximum Line Resistance |
|--------------|-------------------------|
| 2.5A | 3.2Ω |
| 2.0A | 4.0Ω |
| 1.5A | 5.3Ω |
| 1.0A | 8.0Ω |
| 0.5A | 16.0Ω |

Alarm voltage: 16 to 32VDC

Maximum ripple: 0.1VAC

Used for special application only

Two Style Y/Class B or one Style Z/Class A

Total Max. Current: 2.5A

SLC Addressable Device Circuits

32 VDC Max
 Power limited
 Supervised
 Max. current: 0.07A(RMS)
 Maximum wire loop resistance: 50Ω
 Two Style 4 Class B or one Style 6 Class A circuit
 Max. 50 addressable devices
 City Tie Circuits
 Supply Input:
 Voltage: 26 VDC
 18 – 28 VDC for battery
 Current: Max. 0.4A
 Supervised

City Tie-Output 1

Output:
 Normal output voltage: 19-28VDC (open circuit condition)
 Supervisory current: 1mA
 Maximum trip current: 400mA
 Maximum coil plus wire resistance: 22.5Ω

Leased line-Output 1

Normal output voltage: 19-28VDC (open circuit condition)
 Trouble output voltage: 0V
 Alarm output voltage: -(19-28)VDC (open circuit condition)
 Maximum wire resistance: 2-5KΩ
 Maximum short circuit current: 25mA

Leased line-Output 2

Normal output voltage: 19-28VDC (open circuit condition)
 Supervisory output voltage: -(19-28)VDC (open circuit condition)
 Maximum wire resistance: 2-5KΩ
 Maximum short circuit current: 25mA

DACT Circuits

Power limited
 Supervised for short or open circuit conditions
 Compliance to FCC part 68
 Support RJ31X connection
 Compatible Digital Alarm Communication Receiver (DACR) list,

DACT compatibility list

| Device module | Manufacture |
|---------------|-------------|
| MX8000 | Honeywell |

CAUTION – To reduce the risk of fire, use only No. 26 AWG or larger telecommunication line cord.

FC2005/FC901 SYSTEM CONNECTION DIAGRAM

• FC2005/FC901 SYSTEM CONNECTION DIAGRAM

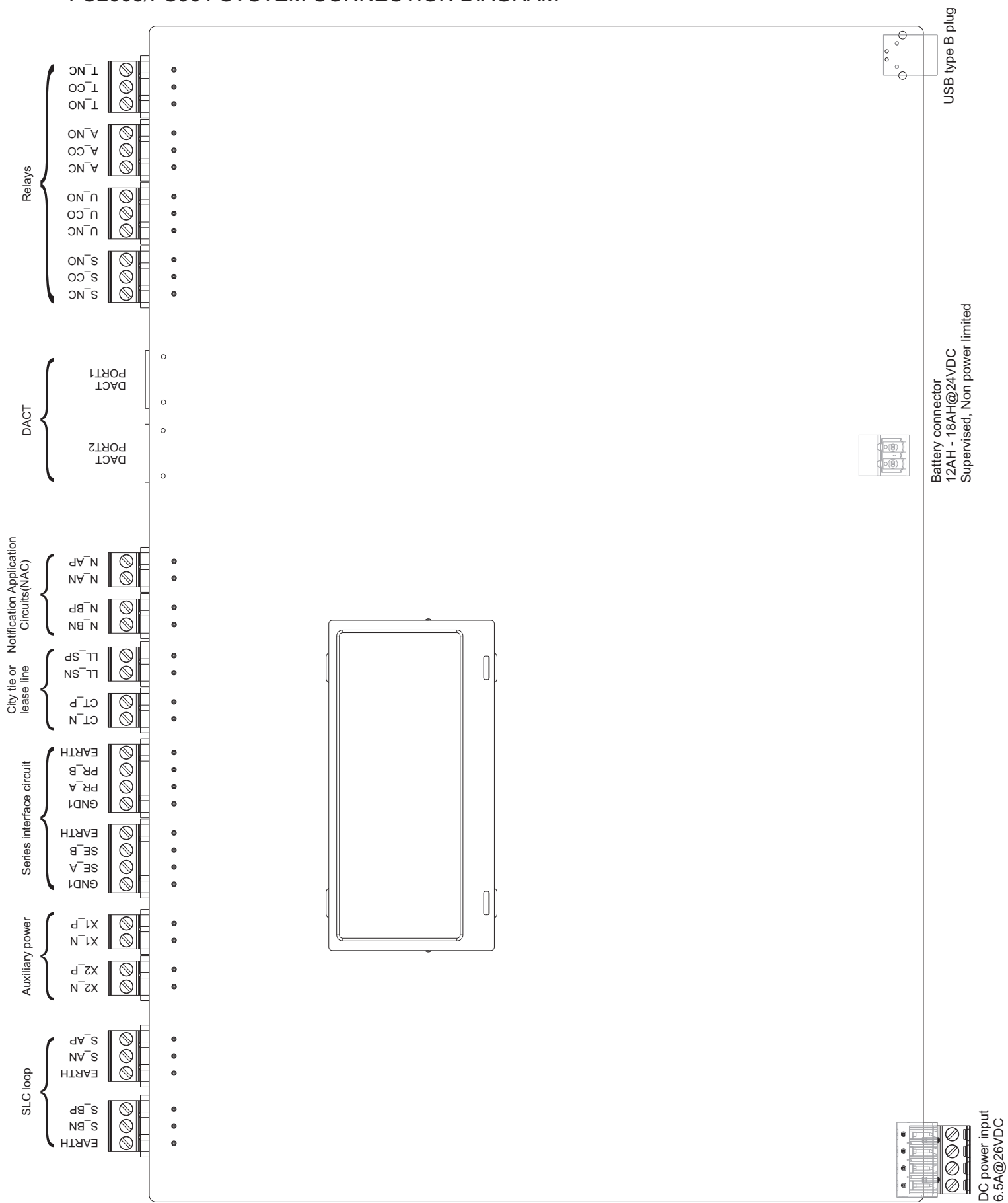

Note: All the wiring must be in according with local codes and National Electric Code.

FC2005/FC901 SYSTEM CONNECTION DIAGRAM

• FC2005/FC901 SYSTEM CONNECTION DIAGRAM

• SLC loop connections

Supervised and power limited, detail device compatibility list refer to user manual Appendix B

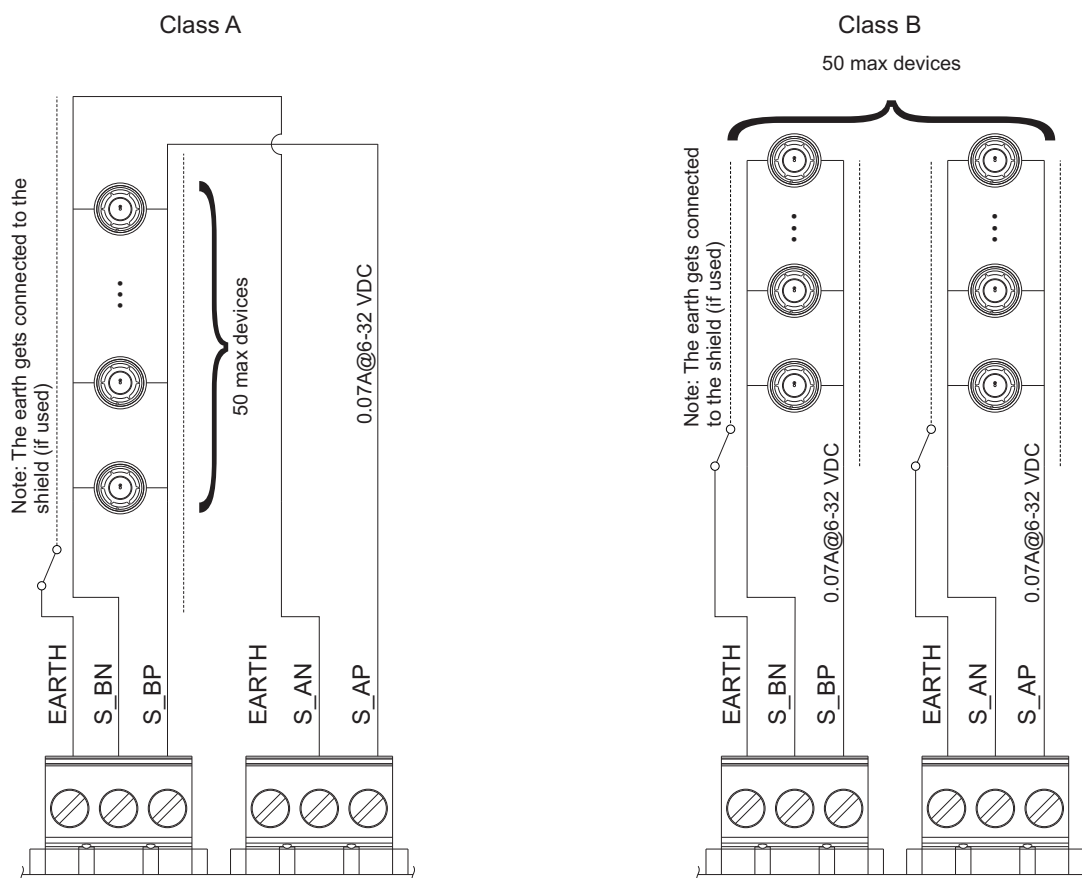

• Auxiliary power

Non supervised and power limited

Auxiliary power output 2
(Resettable, power limited)

Conventional detectors

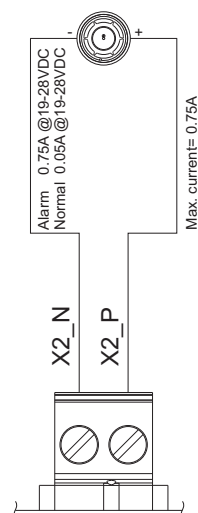

Auxiliary power output 1
(Non-resettable, power limited)

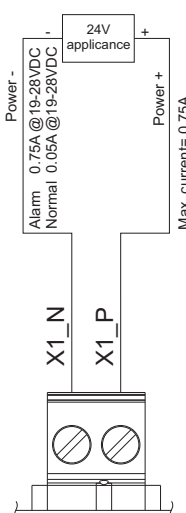

FC2005/FC901 SYSTEM CONNECTION DIAGRAM

• FC2005/FC901 SYSTEM CONNECTION DIAGRAM

• Series Interface Circuit

Power limited

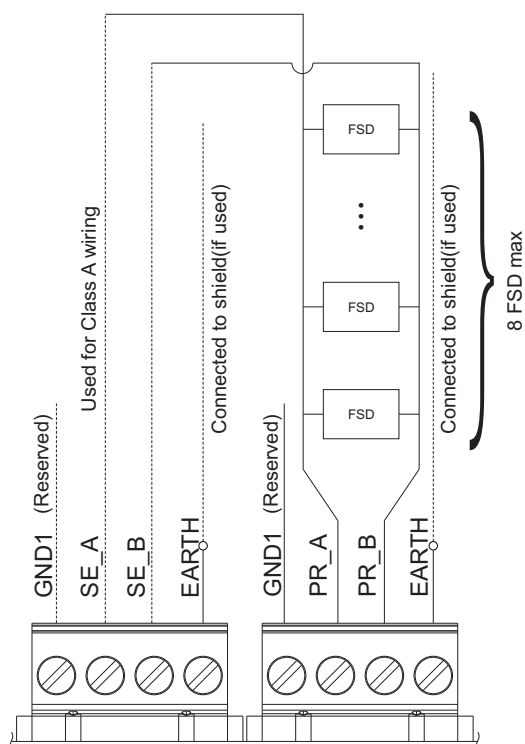

• City tie or lease line

power limited

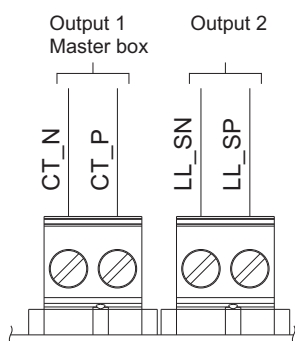

City tie and leased line rating

| | |
|-----------------------------------|--|
| Leased Line Voltage Rating | 100mA@26VDC Active (19-28VDC on Battery) |
| | Polarity Reversing Circuit |
| | +26VDC Normal (OUTPUT 1 and OUTPUT 2) |
| | -26VDC Alarm (OUTPUT 1) |
| | 0V Trouble (OUTPUT 1) |
| | -26VDC Supervisory (OUTPUT 2) |
| External Circuit Resistance | 2K-5K ohms |
| Municipal Tie Voltage | 350mA@26VDC Active(19-28VDC on Battery) |
| | +26VDC Normal & 1mA Supervisory Current |
| | 350mA Alarm@+26VDC |
| Municipal Tie Trip Coil | 14.5 ohms |
| Municipal Tie Supervisory Current | 1mA |

• Notification Application Circuits

Supervised, power limited, Max. current(NAC A+NAC B)=2.5A

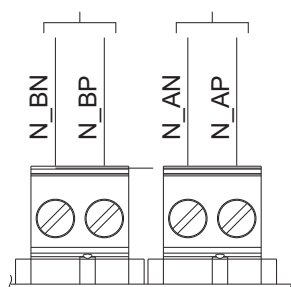

FC2005/FC901 SYSTEM CONNECTION DIAGRAM

• FC2005/FC901 SYSTEM CONNECTION DIAGRAM

• DACT

Power limited



DACT compatibility list

| Device module | Manufacture |
|---------------|-------------|
| MX8000 | Honeywell |

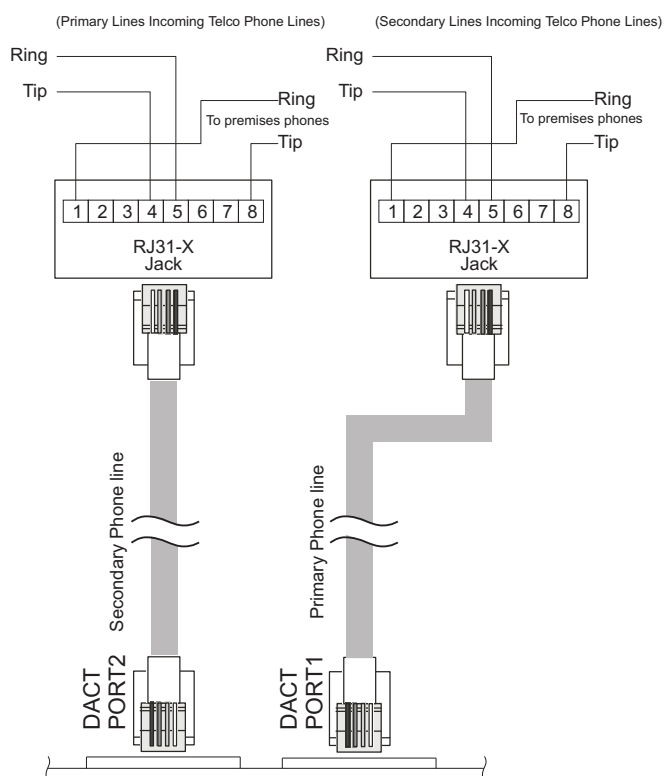

• Relays

Non power limited, 2.0A@30VDC(Resistive), 0.5A@30VAC(Resistive)

