

## FDCIO221-CN Input/Output module Product manual

### Features

---

- Compliance with EN 54-18:2005/AC:2007
- 1 monitored potential-free contact input, 1 monitored control output (output not monitored when module in active status)
- LED indicating input/output status
- Integrated line separator
- Jumper switch control for output monitoring on or off
- Output: 2 A @ DC 24 V
- Microprocessor for signal processing
- Power supply via C-NET
- Communication with the control panel via C-NET (detector line, independently addressable)
- Suitable for dry, dusty or humid environments

### Application

---

#### Input

The module monitors via input signals the status of the potential-free contact (e.g. whether the door is closed or not). The input signals can be configured in the following operating modes:

- Status input or danger input
- Open line or open line/short-circuit monitoring
- The input is activated when the relay is in the following states:
  - Normally closed contact NC open
  - Normally open contact NO closed

#### Status inputs and danger inputs

Danger inputs trigger an alarm as soon as the input is activated. Status inputs trigger a status change as soon as they are activated.

#### Line monitoring

The input lines are monitored for "open line" or "open line/short-circuit" faults. To realize the above function, the input lines must be provided with termination resistors. In the event of a short-circuit or an open line on the input line, a fault message is sent to the control panel. The inputs must be potential-free.

## Output

### Normal operation mode (output monitored)

- For external device control (e.g. activation of a signal sensor)
- External DC 24 V power supply needed
- Output line monitoring for open line and short-circuit when module in inactive status This function can be configured and switched off via the controller.
- The jumper must be plugged into position J2 .

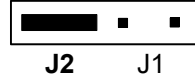

Jumper position J2

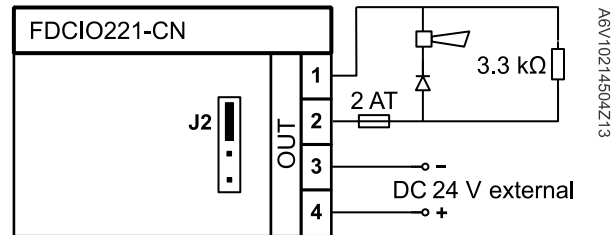

Connection diagram for normal operation with output line monitored for open line and short-circuit



Connect the diode correctly, otherwise the output open line/short-circuit monitoring function cannot be realized.

### Configuration

In normal operation mode, the control output can be configured in the following ways:

- After activation, the output remains in the following status:
  - Permanently active
  - Active only for a certain period of time The duration of active status can be configured via pulse duration.
- Failsafe mode: When the C-NET line loses voltage or is in degraded mode (e.g., CPU failure), the failsafe function will control the state of the output after a failure, according to predetermined program:
  - Output remains in the same position as before the error
  - Output is activated in case of an error
  - Output is deactivated in case of an error
- Output monitoring on or off

### Inverted operation mode (output not monitored)

- For external device control (e.g. door closing)
- External DC 24 V power supply needed
- Output not monitored for open line and short-circuit
- The jumper switch must be connected to the position J2.



Jumper position J2

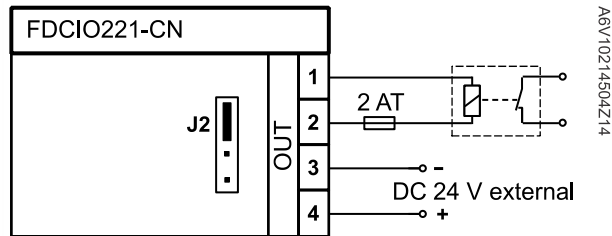

Diagram of connection in inverted operation mode, e.g. for door closers

In the inactive state, maintaining a DC 24 V supply to the outputs allows the door to remain open. When the output becomes active, the output goes into “Open” status (no longer 24 V voltage) and the door is closed.

NOTE: In this example, the door would also close if the 24 V supply were to fail, e.g., due to a line problem (short-circuit, open line).

### Configuration

In inverted mode, the control output can be configured in the following ways:

- After activation, the output remains in the following status:
  - Permanently active
  - Active only for a certain period of time The duration of active status can be configured via pulse duration.
- Failsafe mode: When the C-NET circuit loses voltage or in degraded mode (CPU failure), the failsafe function will follow a predetermined program to control the state of the outputs after a failure:
  - Output remains in the same position as before the error
  - Output is activated in case of an error
  - Output is deactivated in case of an error

### Potential-free contact output (output not monitored)

- Used to control outputs (e.g., closing doors)
- Output not monitored
- No external DC 24 V power supply required
- The jumper switch must be connected to position J1.

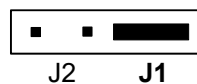

Jumper position J1

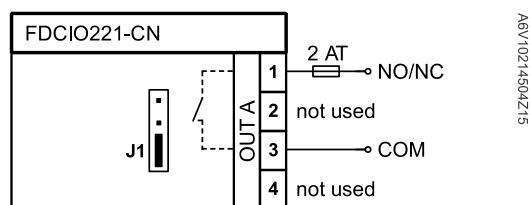

Connection diagram for output which is not monitored



### Voltage rating!

Potential-free contact output, contact capacity: 2 A @ DC 24 V or 2 A @ AC 24 V.

### Configuration

When the output is potential-free, the following configurations are available:

- The following conditions activate output:
  - Closed (normally open contact NO)

- Open (normally closed contact NC)
- After activation, the output will remain:
  - Permanently active
  - Active only for a certain period of time The duration of active status can be configured via pulse duration.
- Failsafe mode: When the C-NET circuit loses voltage or in degraded mode (CPU failure), the failsafe function will follow a predetermined program to control the state of the outputs after a failure:
  - Output remains in the same position as before the error
  - Output is activated in case of an error
  - Output is deactivated in case of an error



The output relay's factory default state is open circuit. However, during transportation and storage, the relay state may change due to impacts and vibrations. After communicating with the control panel, the relay state is reset to the open circuit state. Make sure this input/output module is read on the control panel before connecting the module to the controlled device.

## Structure

The module consists of the module carrier, the printed circuit board and the cover cap. The printed circuit board is equipped with LEDs to indicate the status of the input/output signals. The cover cap of the printed circuit board is transparent such that the status of the LEDs is always visible.

To achieve IP65 protection rating, the housing FDCH221 is available as an option.

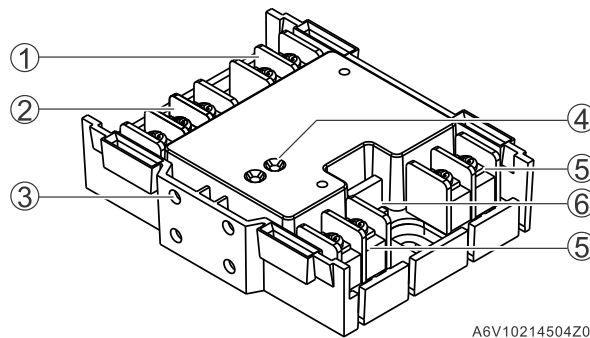

1. Connections for the input
2. Connections for the detector line
3. Holes for mounting feet
4. LED indicator
5. Connections for the output
6. Jumper

A6V10214504Z01

## LED indicator

The table below shows LED status and meaning.

### LED for input status

LED status	Meaning
LED off	Normal operation
LED flashes every 1 s (250 ms ON)	Input activated
LED flashes every 1 s (2~5 ms ON)	Localization mode

### LED for output status

LED status	Meaning
LED off	Output not active
LED flashes every 1 s (250 ms ON)	Output active

The LED displays can be deactivated if necessary (e.g. in a cinema).

## Jumper

Jumper position	Meaning
 J2 J1	Potential-free contact output (output not monitored)
 J2 J1	<ul style="list-style-type: none"> <li>● Normal operation mode: connection for power (output monitoring)</li> </ul>

● Inverted operation mode: connection for power (output not monitored)

NOTE: If the jumper position does not agree with the control panel's configuration, a fault message will be displayed.

## Installation

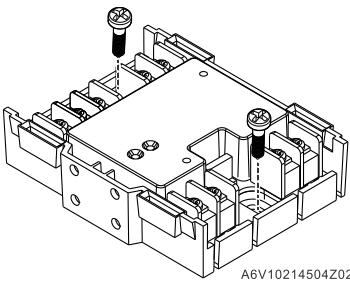

Fig. 1

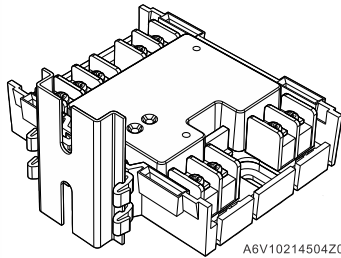

Fig. 2

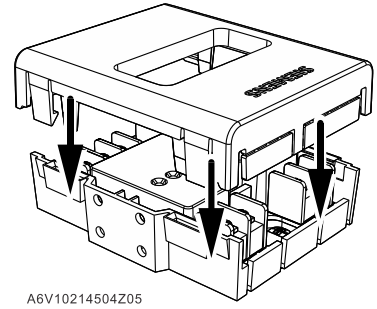

Fig. 3

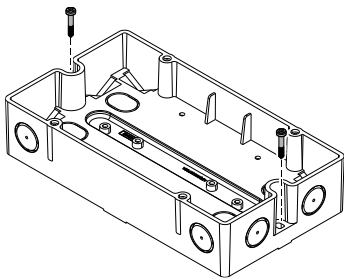

Fig. 4

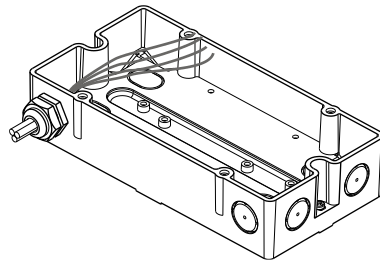

Fig. 5

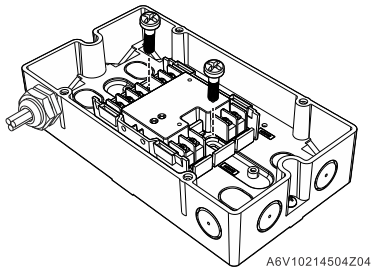

Fig. 6

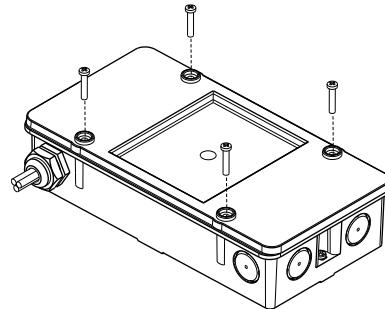

Fig. 7

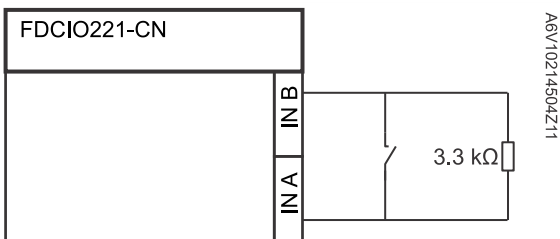

Fig. 8

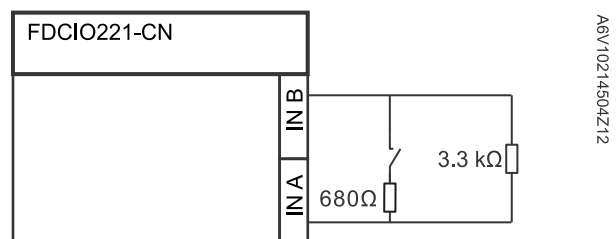

Fig. 9

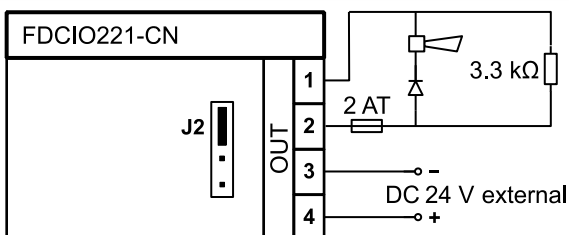

Fig. 10

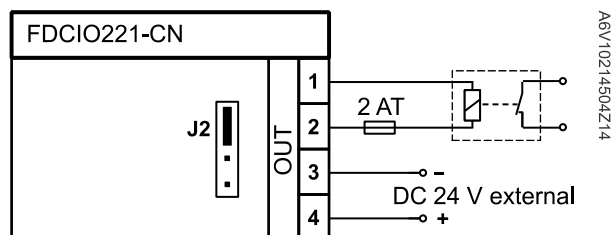
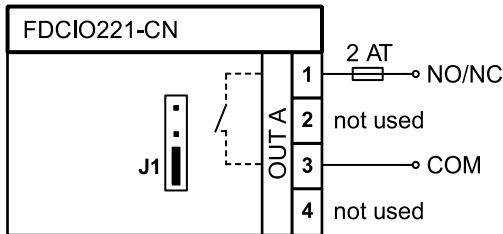

Fig. 11



A6V10214504Z15

Fig. 12

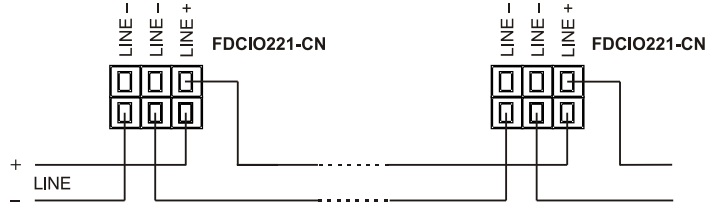

Fig. 13

## Preparation

The installation procedure depends on the module's place of use and type of installation.



### Electric voltage!

Disconnect power during installation.

1. Determine the location of the installation:
  - Installation outside a control panel or an electric cabinet: in FDCH221 housing
  - Installation in a control panel or an electric cabinet: on a DIN rail or on a flat surface
2. Determine the type of installation:
  - Installation on a surface (Fig. 1)
  - Installation on a DIN rail (Fig. 2), installation accessory FDCM291 needs to be ordered separately.
  - Installation in housing FDCH221 (Fig. 6). The housing needs to be ordered separately.

## Installation on a surface

1. Position the module on a flat surface (Fig. 1).
2. Secure the module using two screws (M4) (Fig. 1). Distance between mounting holes: 63.5±1.0 mm.
3. If a top cover is purchased, refer to Fig. 3 for installation.

## Installation on a DIN rail

1. Fix two mounting feet to the module.
2. Press the module and mounting feet against the DIN rail until the feet snap into place (Figure 2).
3. If a top cover is purchased, refer to Fig. 3 for installation.

## Installation in housing

1. Open the housing.
2. Determine the cable entries and break them open.
3. Secure the housing to a flat surface using two screws (M4) (Fig. 4). Distance between mounting holes: 182.0±1.0 mm.
4. Guide in the cables through the cable glands and secure them in the housing (Fig. 5).
5. Fix the module in the housing using two M3 x 12 screws (Fig. 6).
6. Insert the sealing strip and close the housing with the screws (Fig. 7).

! The top cover FDCH1801 cannot be installed if the module is installed in FDCH221.



**To ensure product safety performance, please do not modify the product!**

## Electric connection



When connecting the C-NET line/diode, pay attention to the positive and negative polarity. Connect only one wire to each terminal.

1. Refer to the wiring diagram to connect the cable to the terminals (Fig. 14). Refer to the following data for connection details:
  - Detector line: Fig. 13
  - Input monitored for open line: Fig. 8
  - Input monitored for open line and short-circuit: Fig. 9
  - Output in "Normal operation mode": Fig. 10
  - Output in "Inverted operation mode": Fig. 11
  - Potential-free contact output (not monitored): Fig. 12
  - DC 24 V power supply: Fig. 10/Fig. 11
2. If shielded cable is used for the detection line, join the shielding to the DBZ1190-AB connection terminal. The shielded wires must not touch any other ground potentials or metal parts in the box.
3. Connect the termination resistor (Fig. 8 and Fig. 9). Termination resistors are shipped with the product.
4. Connect the jumper to J1/J2 according to how the output is used (Fig. 10, Fig. 11 and Fig. 12).

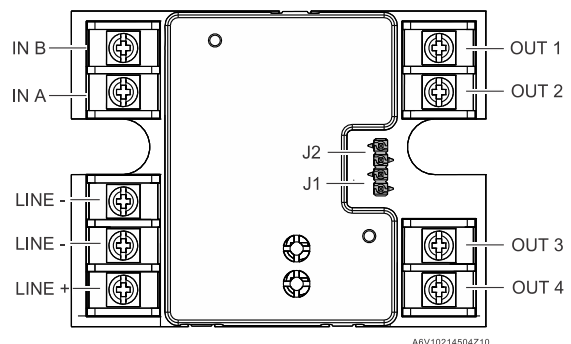
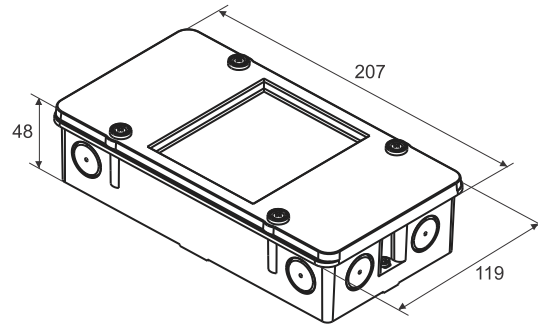
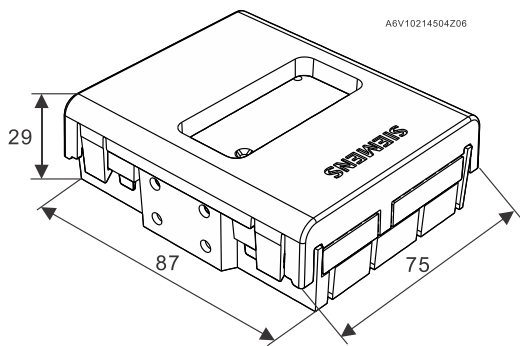
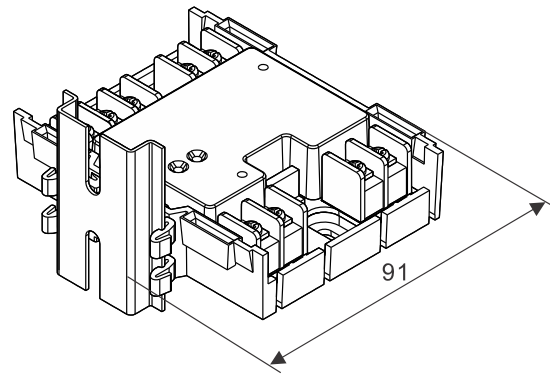
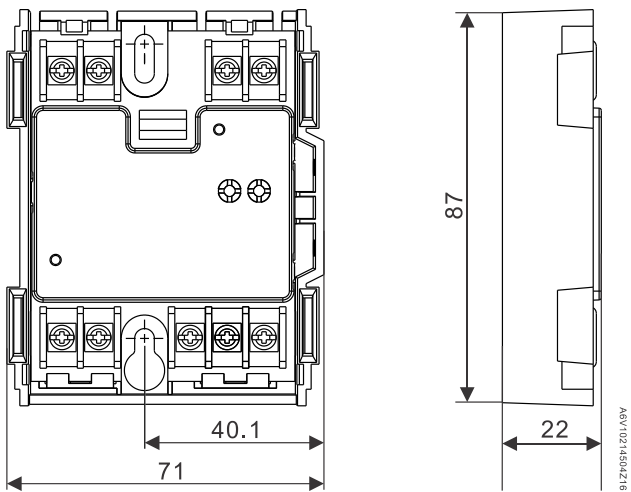

Fig. 14

# Dimensions

In mm



## Maintenance

- Conduct annual visual inspection of all devices. Devices that are heavily contaminated or mechanically damaged must be replaced.
- Any device should be replaced after 12 years of service, independent from the environmental conditions.
- Do not dispose of the product at will after the end of its life. Dispose of it in accordance with relevant national regulations such as the "Regulations on the Administration of Waste Electrical and Electronic Products Recycling and Disposal".

## Technical data

Operating voltage	DC 12...32 V
quiescent current	0.32 mA
Activation current	0.60 mA
Output	
- Capacity (per channel)	2 A @ DC 24 V
- Termination resistor	3.3 k $\Omega$
- Diode	1N5404
Input	
- Termination resistor	3.3 k $\Omega$ / 680 $\Omega$
Operating temperature	-25...+55 °C
Storage temperature	-30...+75 °C
Humidity	$\leq$ 95 % rel.
Communication protocol	C-NET
Electromagnetic compatibility at:	
- 1 MHz~1 GHz	50 V/M
Connection terminals	1.0.... 2.5 mm <sup>2</sup>
Color	
- Module carrier	White, RAL 9010

## Ordering Information

Type	Material no.	Designation	Weight
FDClO221-CN	S54312-F9-A101	Input/Output module	0.065 kg
FDCH221	S54312-F3-A1	Housing	0.274 kg
FDCH1801	S54322-B1-A1	Module cover	0.017 kg

Beijing Siemens Cerberus Electronics Ltd.  
Smart Infrastructure  
No.1 Fengzhidonglu, Xibeiwang, Haidian District  
Beijing, China  
100094  
+86 400 150 6060  
[www.siemens.com/buildingtechnologies](http://www.siemens.com/buildingtechnologies)

© Siemens 2025  
Data and design subject to change without notice.