

Powermite 599

MT Series SSC61.5U Electronic Valve Actuator, 24 Vac/dc Proportional Control with Electronic Fail-Safe

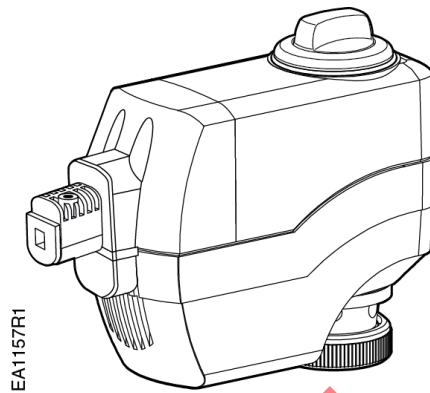

Description The Powermite 599 MT SSC61.5U electronic valve actuator requires a 24 Vac or 24 Vdc supply and a 0 to 10 Vdc control signal. They proportionally control Powermite 599 MT Series valves with a 7/32-inch (5.5 mm) stroke and a threaded valve bonnet that fits the actuators.

- Features**
- UL listed for plenum installations.
 - Direct-coupled installation without special tools.
 - Manual override.
 - Visual position indication.

Application The Powermite 599 MT SSC61 series electronic actuators and MT Series valves are used in closed loop heating and cooling applications. They control hot or chilled water or steam (<5 psi) for convectors, fan coil units, unit conditioners, radiation, reheat coils, and similar terminal units. The SSC61.5U actuator accepts a plenum cable or 3/8-inch flex conduit connection.

Product Numbers

Table 1. Product Numbers.

Actuator	Operating Mode	Actuator Prefix Code
SSC61.5U	Spring Return (Fail-Safe)	262

Ordering a Valve Plus Actuator Assembly To order a complete valve plus actuator assembly from the factory, combine the actuator prefix code with the suffix of the valve product number. See *Technical Bulletin TB251, Powermite 599 Series MT Series Terminal Unit Valve and Actuator Assembly Selection* (155-306P25) for selection procedures.

To order an actuator only, use the product number.

Specifications

Power requirements	Operating voltage	24 Vac \pm 20%, 24 Vdc \pm 20%
	Frequency	50/60 Hz \pm 2 Hz
	Power supply	24 Vdc or earth ground isolating, Class 2, 24 Vac transformer
	SSC61.5U power consumption	NOTE: Do not power more than 10 actuators with one transformer. 3 VA at ultra cap load, 2 VA at normal operation
Control characteristics	Control signal (Y) Voltage	0 to 10 Vdc (default) or 0 to 20 mA with external 500 ohm, 0.2W resistor
	Current	0.1 mA
Functional operation	Running time at 50/60 Hz	30 sec \pm 10%
	Electronic Fail-Safe	(Figure 1) \approx 30 seconds
	Nominal stroke	7/32-inch (5.5 mm)
	Nominal force	67 lb (300N)
	Stroke/signal relationship	Linear
	Capacitor charge time (Figure 1)	maximum 180 seconds
	Spring return (SSC61.5U only)	Non-mechanical, electronic return fails to stem up (0 position)
Agency certification	UL	UL873 Listed
	cUL	Certified to CSA C22.2 No. 24-93
Ambient conditions	Ambient temperature Operation	41°F to 122°F (5°C to 50°C) with
	Transport and storage	-13°F to 158°F (-25°C to +70°C)
	Ambient humidity	0 to 90% rh (non-condensing)
	Media temperature	35°F to 230°F (2°C to 110°C)
Physical characteristics	Wiring Connection	Plenum cable or 3/8-inch flex conduit
	Weight	0.61 lb (0.27 kg)
	Dimensions	See Figure 7

Operation

The stroke of the actuator shaft is proportional to the control signal on terminal Y. A 0 Vdc control signal retracts the shaft.

In the event of a power failure, the SSC61.5U returns to the stem up position. The SSC61.5U includes an electronic return mechanism that functions as follows (Figure 1):

- At power-up (t_0), a capacitor must charge to its maximum capacity (Max, t_c). This will take a maximum of 180 seconds, during which time no actuator movement occurs.
- Once the capacitor is fully charged (t_c), normal actuator operation occurs.
- If a subsequent power failure occurs (t_n) longer than 5 seconds, the capacitor discharges (t_d) and the actuator returns to its normal spring return position.

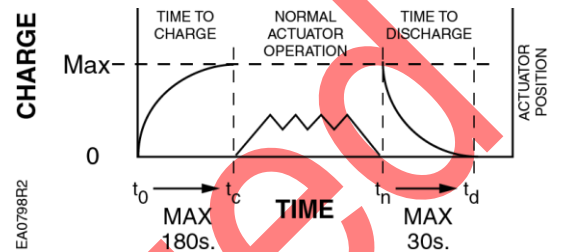

Figure 1. SSC61.5U Electronic Spring Return Mechanism.



CAUTION:

Before applying power, make certain a valve is connected to the actuator.

If applying power to the actuator when a valve is not connected, the actuator will respond to a control signal and the shaft will extend until it reaches its maximum end stop. Thereafter, it will not respond to any signal.

If this occurs:

1. Disconnect power.
2. Turn the manual position indicator (see Figure 5 and Figure 6) on the top of the actuator to the 0 position and verify that the actuator shaft retracts completely.
3. Connect a valve to the actuator, and reapply power. The actuator will return to normal operation.

Operation, Continued

Calibration Stroke

The SSC61.5U writes its calibration stroke parameters to nonvolatile memory on the first start-up of the actuator. Successive start-ups bypass the calibration stroke unless the memory is manually cleared. If installing the actuator on a different valve (such as on a replacement valve), manually clear the calibration stroke from memory as follows:

1. Remove the terminal cover using a Phillips head screwdriver.
2. Locate the hole on the circuit board with the shorting bars.
3. With power applied to the unit, insert and gently twist a flat-blade screwdriver to electrically connect the shorting bars (Figure 2). The SSC61.5U then performs a new calibration stroke.
4. Secure the terminal cover back in place.

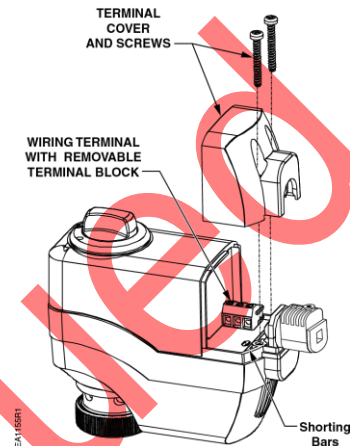

Figure 2. Manually Clearing Calibration Stroke from Memory.

Mounting and Installation

Mount the actuator in one of the allowable positions shown in Figure 3.

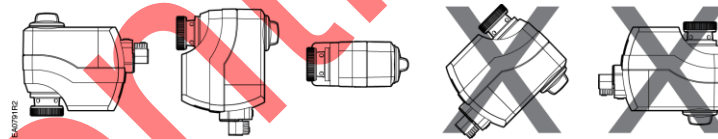

Figure 3. Mounting Position.

When mounting the actuator in a plenum, the proper cable must be attached to meet local codes.

Allow 8 inches (200 mm) above the actuator and 8 inches (200 mm) behind the cable for service.

Wiring

Use earth ground isolating, step-down Class 2 transformers. Do not use autotransformers.

Determine the supply transformer rating by summing the total VA of all actuators used. The maximum rating for a Class 2 step-down transformer is 100 VA.

Do not power more than 10 actuators by one transformer. (Use 0.5 amp fuse on secondary per actuator.)



CAUTION:

Terminals must be properly wired for correct function and full life of the actuator.

Wiring Diagrams

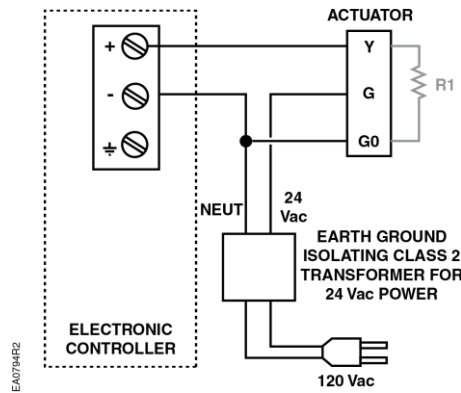

- G, G0 24 Vac or 24 Vdc operating voltage
- Y 0 to 10 Vdc control signal
- G0 System neutral
- G System potential
- R1 500 ohm resistor (optional for 0 to 20 mA operation)

Figure 4. SSC61.5U Wiring.

Manual Override

For manual positioning, use the manual override knob in the center of the position indicator, See Figure 5.

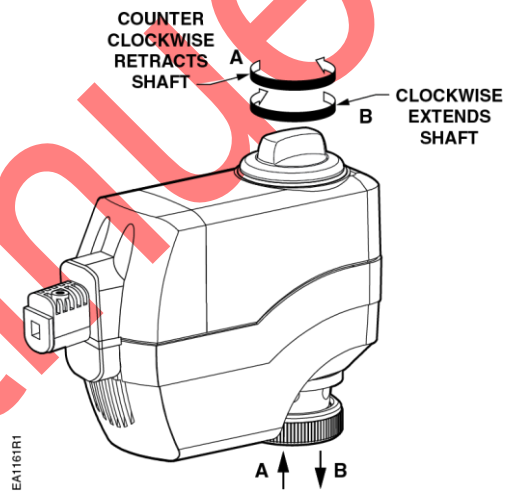

Figure 5. Manual Override.

Start-up

Check the wiring and the position indicator (Figure 6).

Position Indicator	Output Shaft
0	Retracted
1	Extended

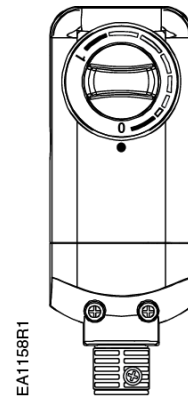

Figure 6. Top View of Position Indicator (Shown in the 0 Position).

Troubleshooting

Check the wiring for proper connections.

Service

If the actuator is inoperative, replace the unit.

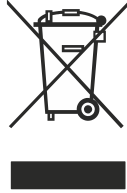
Disposal

The device is considered electrical and electronic equipment for disposal in terms of the applicable European Directive and may not be disposed of as domestic garbage.

- Dispose of the device through channels provided for this purpose.
 - Comply with all local and currently applicable laws and regulations.
-

Dimensions

Figure 7. SSC61.5U Series Actuator Dimensions in Inches (Millimeters).

Service Envelope

Minimum access space recommended:

8 inches (200 mm) above the actuator and beside the terminal cover.

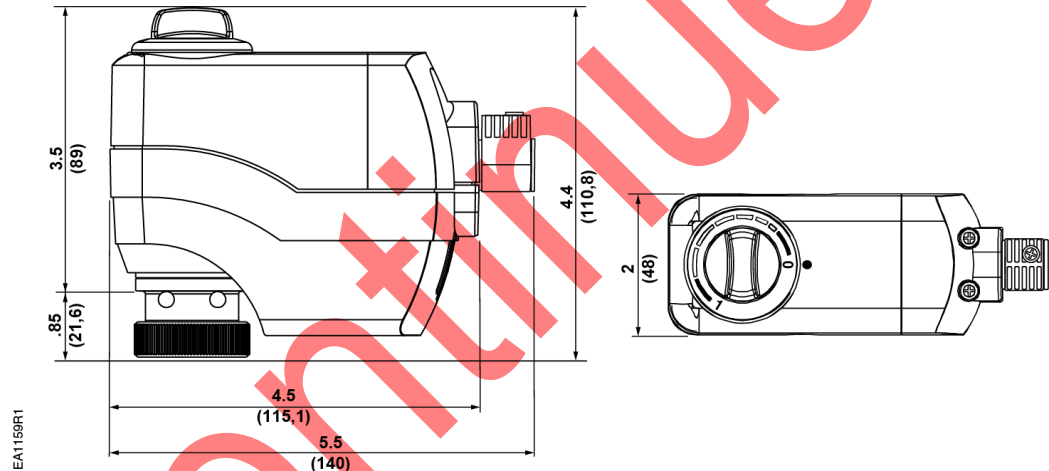
Information in this publication is based on current specifications. The company reserves the right to make changes in specifications and models as design improvements are introduced. Product or company names mentioned herein may be the trademarks of their respective owners.
© 2018-2023 Siemens Industry, Inc.