

Easylink to Allen-Bradley Module

Product Description

The Easylink Module mounts in an enclosure (P/N 587-300, 115 Vac or P/N 587-295, 230 Vac).

Once installed, the Easylink Module is positioned approximately 2-1/4-inches off the back wall of the enclosure on a board bracket and four standoffs. There are two man-machine interface (MMI) ports on the Module—the MMI and the MMI MODEM. These ports are RS-232 ports with quick-connect RJ-11 jacks.



All circuits are supervised, except for the MMI MODEM and MMI ports.

The Memory Board, which is located underneath the Memory Board cover, plugs into the Easylink Board and contains the Allen-Bradley module firmware (read-only memory (ROM)).

Power is supplied to the Easylink Board via a 12 Vdc plug-in power supply (P/N 545-132, 115 Vac or 545-136, 230 Vac).



See the *Easylink to Allen-Bradley Technical Manual* (587-346) for further information about the system installation and programming constraints.

Product Numbers

587-371	Easylink to Allen-Bradley module
538-670	Trunk Interface II, 115V
538-675	Trunk Interface II, 230V
538-755	Trunk/RS-422 Interface, 115V
538-760	Trunk/RS-422 Interface, 230V
545-132	FLN Controller Plug-in Power Supply, 115 Vac
545-136	FLN Controller Plug-in Power Supply, 230 Vac
545-710	Battery Replacement Kit. See Installation Instructions 545-408

Caution Notation



CAUTION:

Equipment damage, or loss of data may occur if the you do not follow the procedure as specified.

Required Tools and Materials

- Electro-static discharge (ESD) wrist strap
- Flat-blade screwdriver (1/8 inch blade width)
- Wire strippers
- One 115V or 230V (depending on device) receptacle to power the auxiliary devices
- Cabling and connectors (Figure 7, Figure 8, and Figure 10).



CAUTION:

Always wear an electro-static discharge wrist strip and discharge accumulated static before touching field panel components.

Prerequisites

- Easylink enclosure installed (see *Installation Instructions 587-301*).
- All conduit runs to enclosure complete (Figure 7, Figure 8, and Figure 10).
- Staefa and Allen-Bradley systems installed and checked out by certified representatives for each system. These checkouts must confirm that each system is operating and ready to communicate with the other system.
- Communication network wire runs from the dedicated Staefa Net Controller Trunk to Easylink with wire leads stripped and mating connector available.

- All required tools and prerequisites from Allen-Bradley System completed.

Expected Installation Time

15 minutes

Voltage, Current Ratings

BLN, FLN Trunk	RS-485 Standard
MMI, MMI/Modem Port	RS-232 Standard

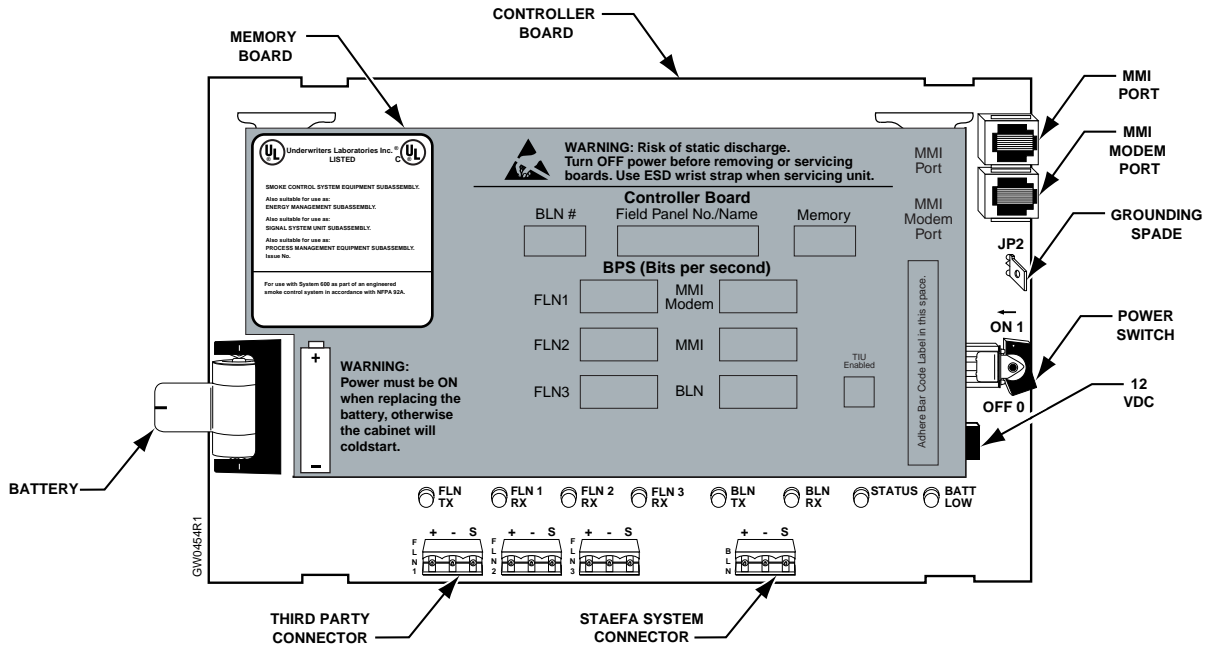

Figure 1. Easylink Controller Module.

Instructions

Preparing to Install the Easylink Board



CAUTION:

Before removing or installing the Easylink Board, ensure that the power switch is shut OFF on the board (Figure 1).

- Place the electro-static discharge (ESD) wrist strap on your wrist and attach it to a good earth ground.
- Remove the temporary connector cover that is wrapped around the board bracket (Figure 2).
- Remove the FLN and BLN connectors from the temporary cover. Reserve the connectors for later use.
- Discard the temporary connector cover.

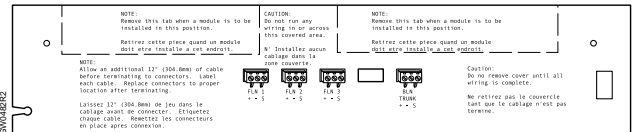

Figure 2. Temporary Cover.

Installing the Easylink Board

- Unpack the Easylink Module from the anti-static bag.
- Rotate the top two plastic stand-offs on the board bracket so that the clip of the standoff is positioned at the top. (Figure 3).

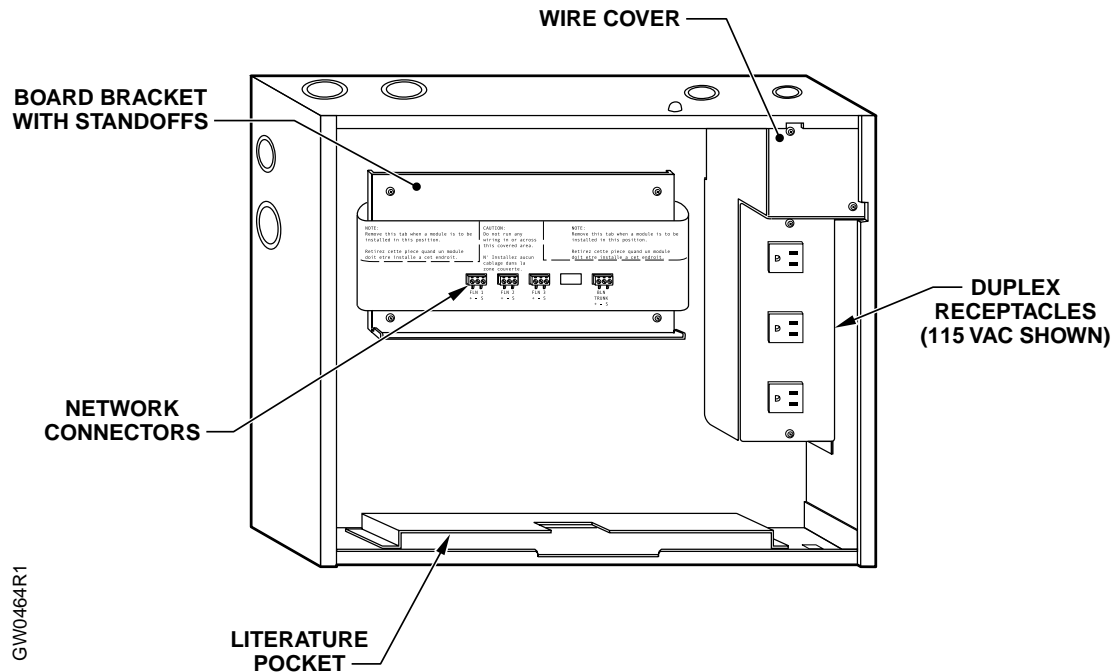

Figure 3. Easylink Enclosure; Inside View.

3. With the LEDs and FLN connectors facing you, slide the bottom of the board at a 10° angle into the bottom guides on the board bracket (Figure 4).
4. Position the Module over the standoffs.
5. Straighten the grounding strap so that the spade connector is not behind the Easylink bracket.
6. Push the Module cover back until each standoff snaps into position.
7. Plug the grounding strap wire into the grounding spade labeled JP2 on the Easylink Module (Figure 1).

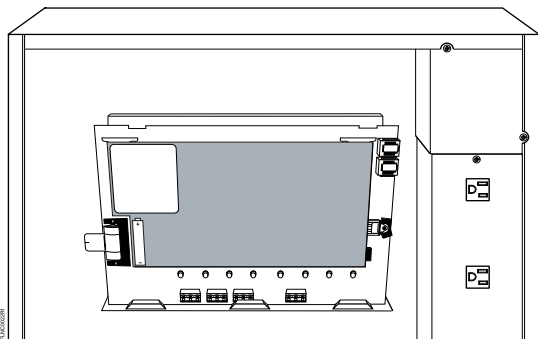

Figure 4. Module Installation.

Connecting Easylink to the Staefa Net Controller Trunk

1. Connect the Easylink BLN Port and the Staefa Net Controller Trunk using the guidelines in Figure 7.
2. Move the TTL/485 switch to the RS-485 position for the trunk that is dedicated to Easylink (Figure 5).
3. Cycle power to the Staefa Net Controller.



CAUTION:

If you do not correctly position this switch, the Easylink will not communicate with the Staefa System.

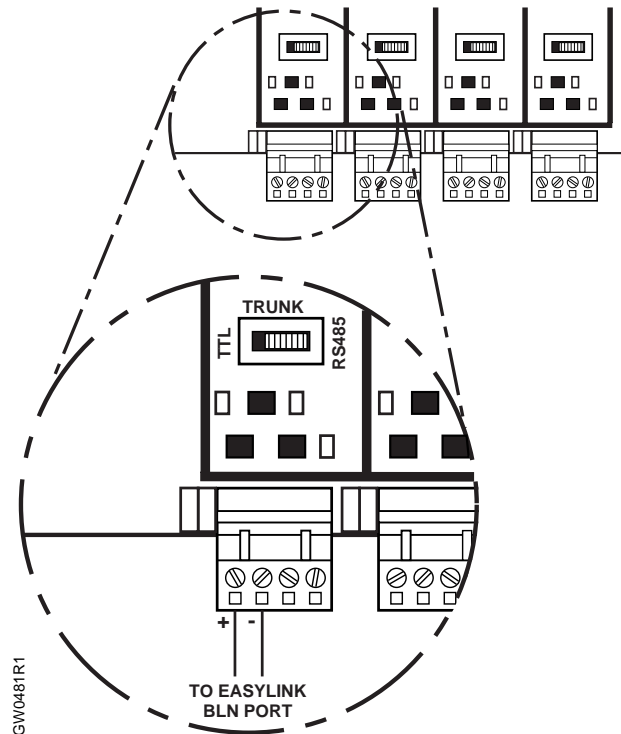

Figure 5. Staefa Net Controller TTL/485 Switch.

Connecting Easylink to an Allen-Bradley 1785 KE or 1770 KF-2 device using a Trunk Interface II

1. Attach the FLN 1 wires to the three-position trunk connector as indicated on the rear panel of the Trunk Interface II (Figure 6). The shield should be taped back or connected as required to obtain a single-ended earth grounded shield.
2. Connect the stripped end of the earth ground wire to the shield position of the *PMD Trunk Connect* and connect the other end (ring terminal) to earth ground (for example, mounting plate screw of outlet, field panel chassis mounting screw, or other suitable earth ground location).
3. Plug the DC power cord into the transformer connector on the Trunk Interface II. Then plug the power pack into the appropriate power source.

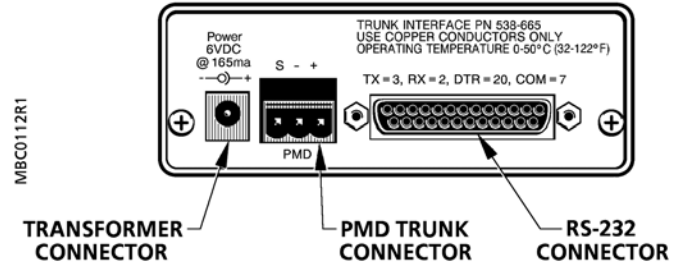

Figure 6. Rear Panel of the Trunk Interface II.

4. Make cable per diagram in Figure 7 or Figure 8.
5. Connect cabling to the Allen-Bradley System using the guidelines in Figure 7 or Figure 8.

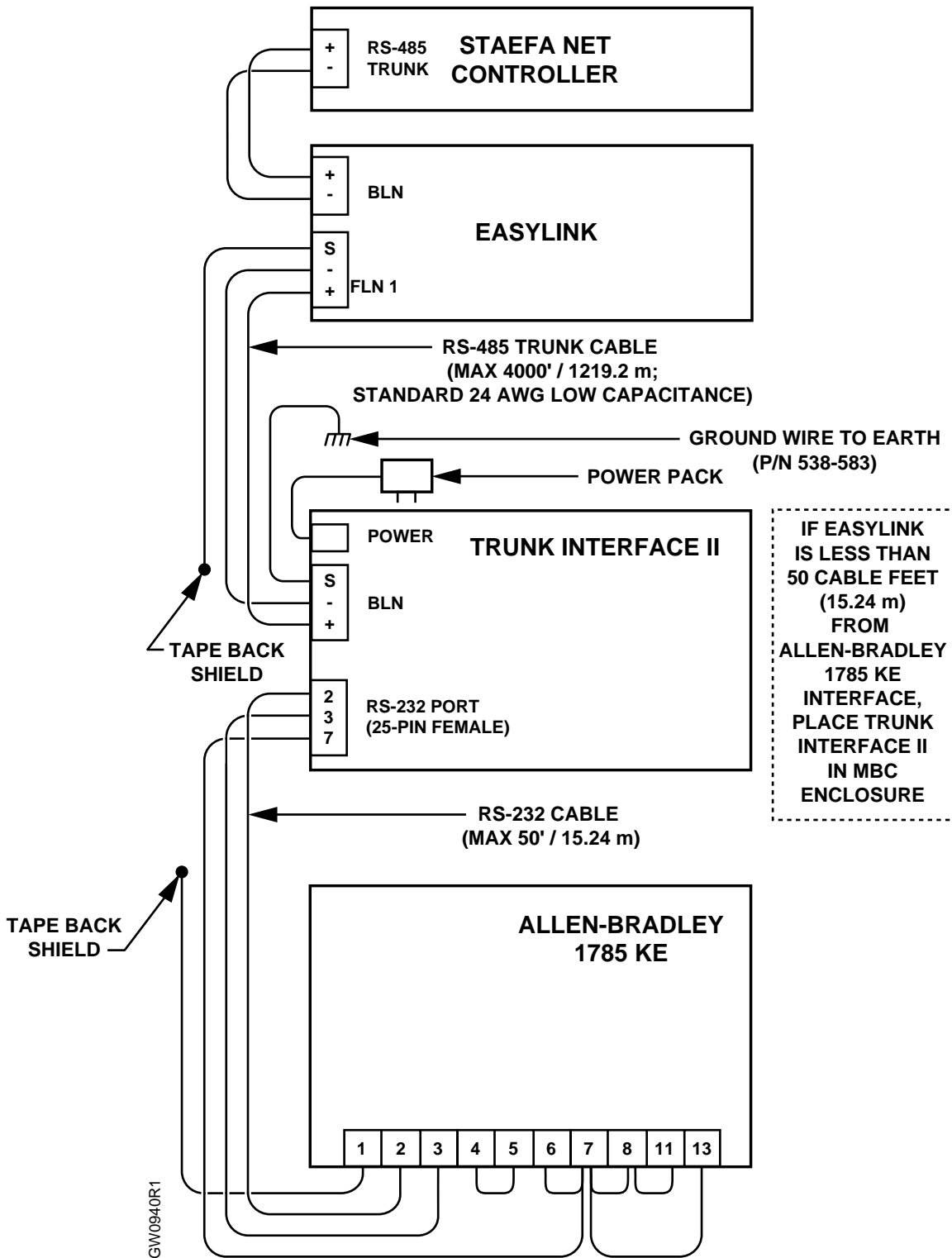

Figure 7. Easylink Wiring Diagram to Allen-Bradley 1785-KE using a Trunk Interface II.

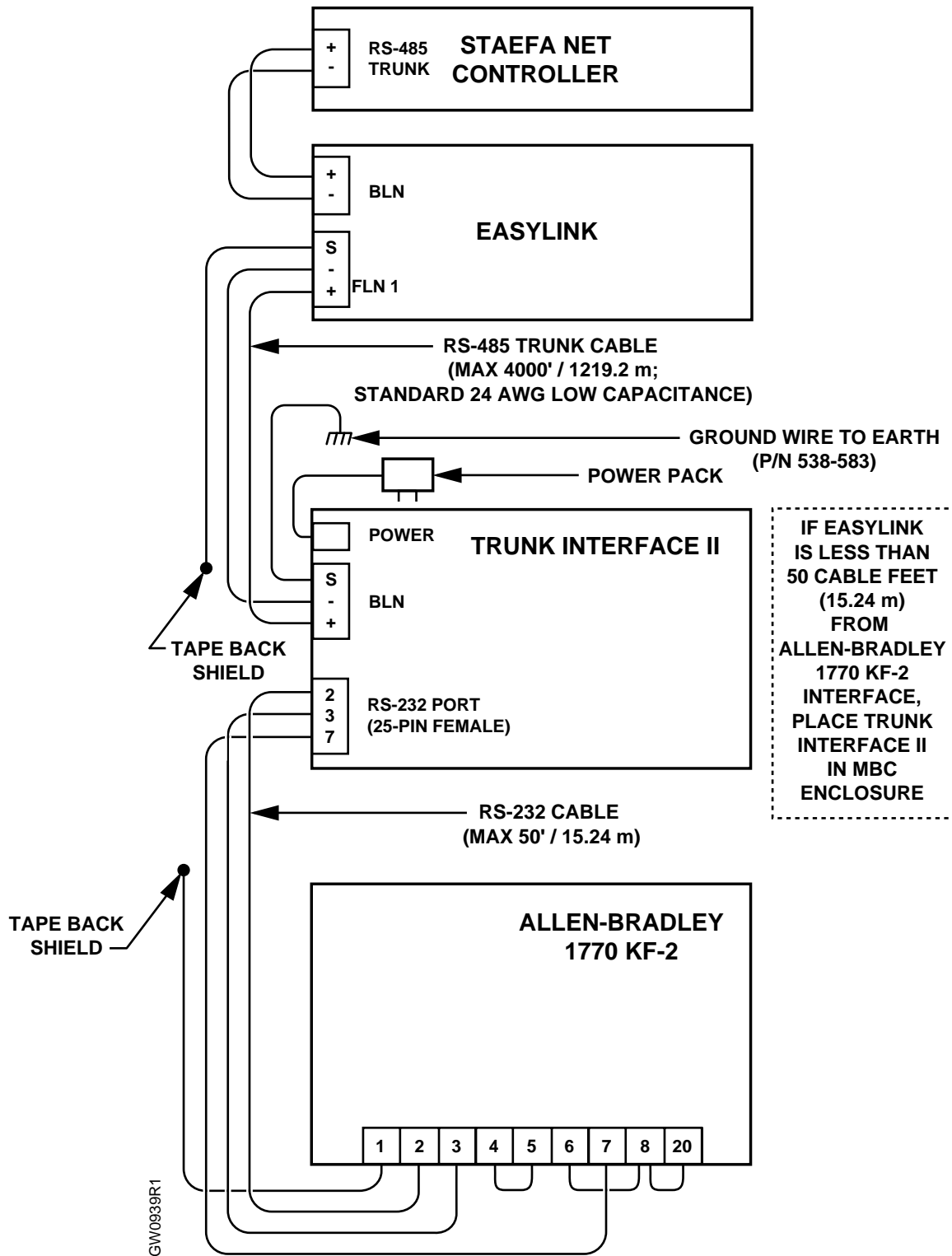

Figure 8. Easylink Wiring Diagram to Allen-Bradley 1770-KF-2 using a Trunk Interface II.

Connecting Easylink to an Allen-Bradley 1770 KF-2 using a Trunk/RS-422 Interface

1. Attach the FLN 1 wires to the three-position trunk connector as indicated on the rear panel of the Trunk/RS-422 Interface (Figure 9). The shield should be taped back or connected as required to obtain a single-ended earth grounded shield.
2. Connect the stripped end of the earth ground wire to the shield position of the *PMD Trunk Connect* and connect the other end (ring terminal) to earth ground (for example: mounting plate screw of outlet, field panel chassis mounting screw, or other suitable earth ground location).
3. Plug the DC power cord into the transformer connector on the Trunk/RS-422 Interface. Then plug the power pack into the appropriate power source.

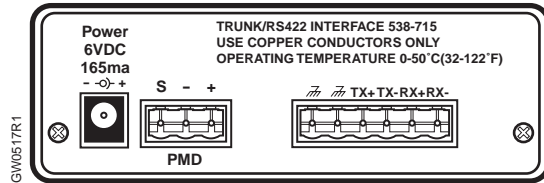

Figure 9. Rear Panel of the Trunk/RS-422 Interface

4. Make cable per diagram in Figure 10.
5. Connect cabling to the Allen-Bradley System using the guidelines in Figure 10.

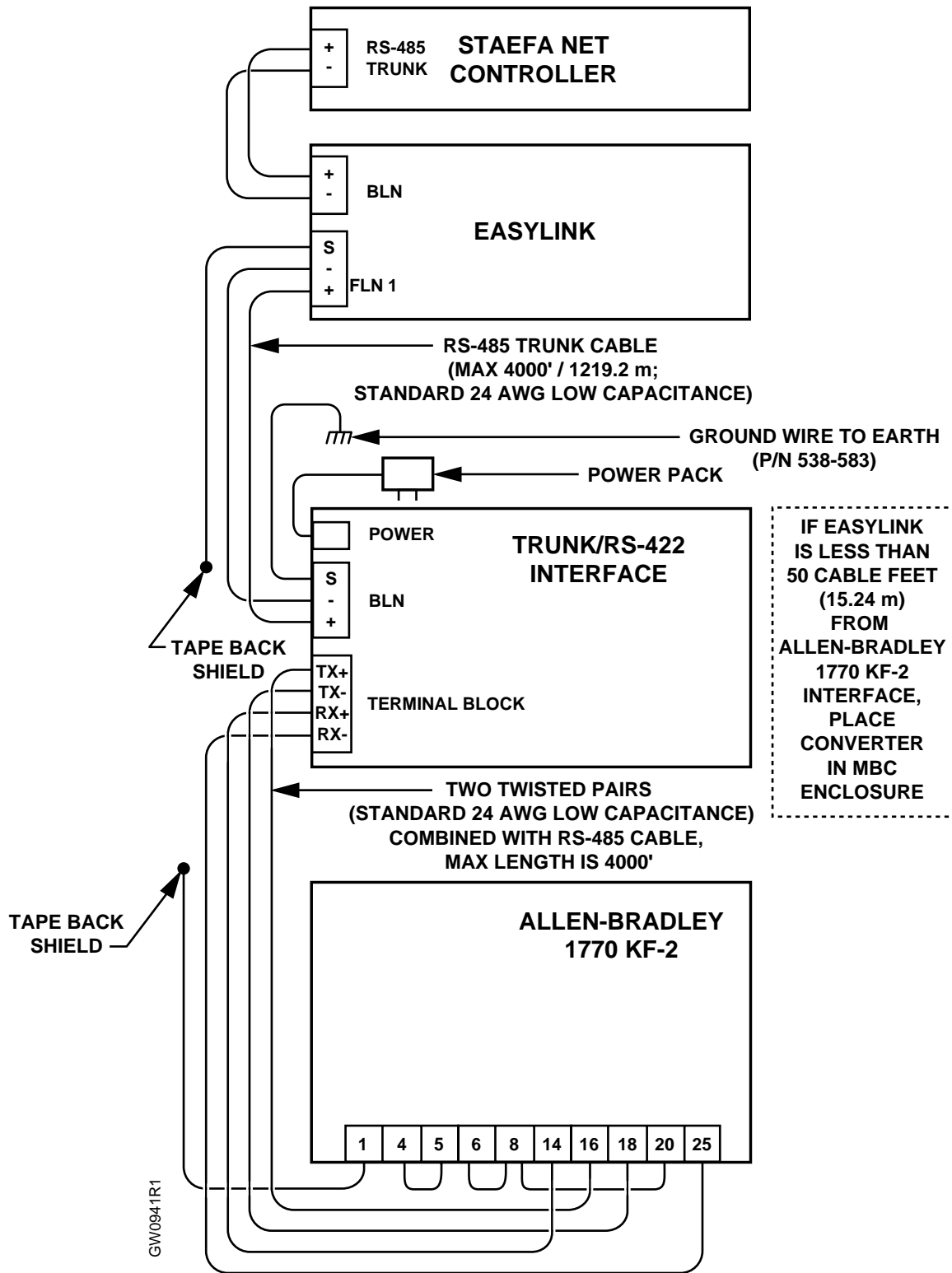

Figure 10. Easylink Connection to the Allen-Bradley 1770 KF-2 using a Trunk/RS-422 Interface.

Powering the Easylink to Allen-Bradley System

1. Insert the DIN plug into the DIN socket labeled "12 Vdc" on the Easylink Module (Figure 11).

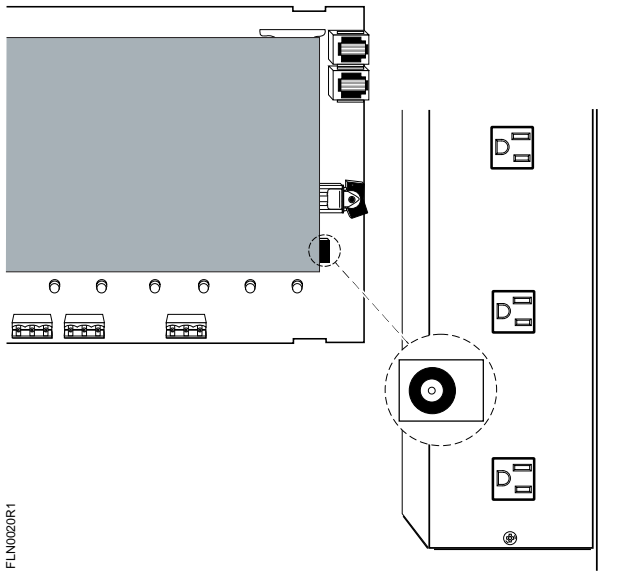

Figure 11. 12 Vdc Power Supply Connection to Easylink Module.

2. Plug the power pack into the power receptacle of the Easylink Enclosure (Figure 12).

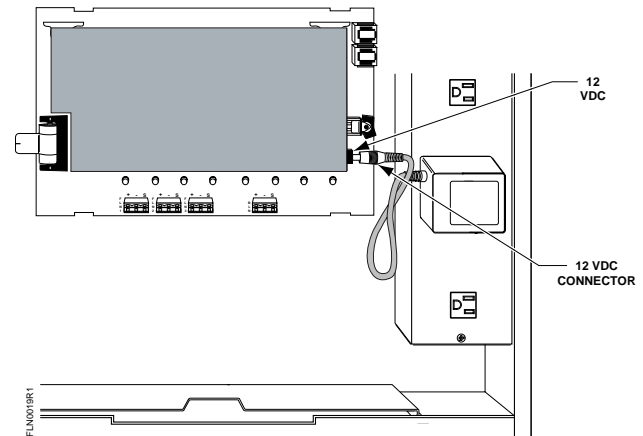

Figure 12. 115 Vac Power Supply Plugged into Power Receptacle.

3. Switch on power to Easylink (Figure 1).



Power is on when the status LED on the bottom of the board is flashing.

4. Holding the battery in place, pull mylar strip off of top of battery (Figure 13). Do not remove the battery pull tab.

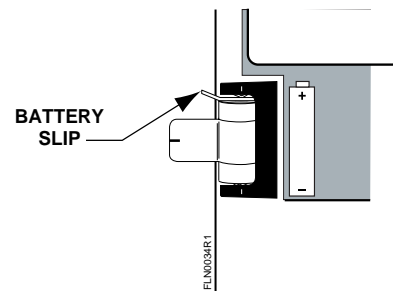

Figure 13. Battery with Mylar Strip.

The installation is now complete.

Information in this publication is based on current specifications. The company reserves the right to make changes in specifications and models as design improvements are introduced. Other product or company names mentioned herein may be the trademarks of their respective owners. © 2002 Siemens Building Technologies, Inc., Staefa Product Group