



TX-I/O™

Triac module

TXM1.8T

- Used for – Thermic and motor-driven actuators (AC 24 V)
 – AC 24 V-controlled devices

- 8 triac outputs (AC 24 V), configured individually for:
 - Permanent contact
 - Three-point positioning output with internal stroke model
 - Pulsewidth-modulated output (PWM)
- Noisefree switching of outputs
- Compact design as per DIN, requiring little space
- Separation into terminal base and electronics unit for optimal handling.
 - Self-connecting bus for the easiest possible installation.
 - Isolating terminal function for fast commissioning.
 - Exchange of electronics unit within seconds without a need of rewiring, at full functionality of the remaining I/O modules
- All terminals are connected directly to the modules, no additional terminal strip for direct connection of field devices.
- Simple display concept
 - Green LED per output, control action as per I/O function
 - LEDs for fast fault diagnosis
- Double-sided labeling of all I/O points with label

Functions

The module supports the following output functions:

Signal type TRA	Signal type	Description
BO Triac NO BO Triac NC	Q250_T	Maintained contact
BO 3-Pos Triac	Y250_T	Pulse, actuating signal, 3-point output, internal stroke model
BO PWM	PWM	Pulse width-modulated output

See document "TX-I/O™ Functions and operation", CM110561, for a detailed description of this function.

Compatibility

For signal type support and functionality in the various building automation and control systems, see TX-I/O™ engineering and installation manual, CM110562.

Ordering

Type	Stock number	Designation
TXM1.8T	S55661-J106	Triac module

Delivery

Terminal base and electronics unit are assembled and delivered in a box.

Accessories

Address keys, printable label sheets and replacement label holders are available as accessories. See data sheet CM2N8170.

Design and technology

See the TX-I/O™ Engineering and installation manual, CM110562, for a description of the properties for all TX-I/O™ modules.

Operating and display elements

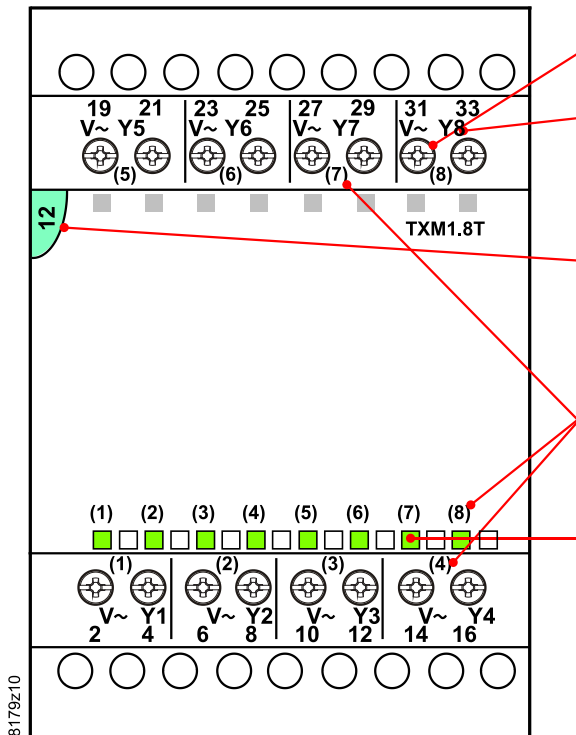

Connection terminals (No. 1 screwdriver for slotted or recessed-head * screws)
with test plug socket (pins 1.8 to 2 mm) and terminal number.

Signal designation

Address key and module status LED

I/O point numbers

Output status LEDs (green)

* Combined slotted / recessed-head screws from mid-2012

Output status LEDs

- The status LEDs indicate the status of the outputs.

Module status LED

- The module status LED illuminates the transparent address key.
- The LED (green) indicates the status of the entire module.
- It can also be used for diagnostic purposes.

Address key

- The module only works with the address key.
- The module address is mechanically encoded in the address key.
- Swing out the address key when exchanging the electronics unit. The key remains in the terminal base.

Terminals

- Two terminals per output are available to connect the load.
- The AC 24 V connection is common for all outputs, it comes from the V~ island bus connector.
- The load is balanced to ground.
- Each output is protected individually against overload.

Module labeling

The electronics unit has a removable, transparent lid (label holder) allowing for insertion of the label.

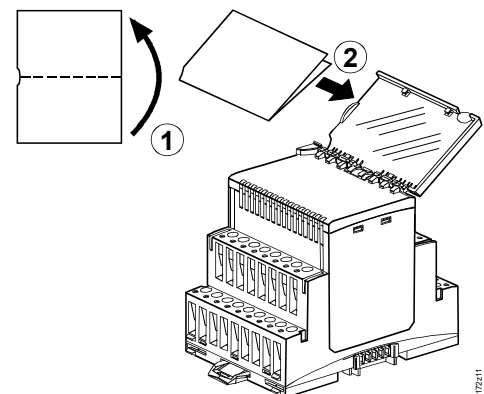

Disposal



This symbol or any other national label indicates that the product, its packaging, and, where applicable, any batteries may not be disposed of as domestic waste. Delete all personal data and dispose of the item(s) at separate collection and recycling facilities in accordance with local and national legislation. For additional details, refer to www.siemens.com/bt/disposal.

Engineering, mounting, installation

Please consult the following documents:

Document	Number
TX-I/O™ Functions and operation	CM110561
TX-I/O™ Engineering and installation manual	CM110562

Mounting

Allowed mounting positions

TX-I/O™ devices can be mounted in any position:

You must ensure, however, that sufficient ventilation is available to maintain the permissible ambient temperature (max. 50 °C).

Technical data

Power supply (side bus connector)	Operating voltage range	DC 21.5...26 V (SELV / PELV) or DC 24 V class 2 (US)
	Max. power consumption <i>(see CM110562 for supply design)</i>	1.0 W
Protection	All module terminals	Against short circuit and faulty wiring using AC/DC 24 V.
	Side bus connector	No protection!
Switching outputs	Number of switching outputs	8
	Switching voltage	AC 24 V
	<i>The supply is AC 24 V from island bus; the triac closes the contact to ⊥ (system neutral)</i>	
	Max. current load	AO 3-Pos triac 250 mA / 6 VA per output
		AO PWM 125 mA / 3 VA per output *)
	BO Triac NO/ NC 125 mA / 3 VA per output *)	
	Total per module 1 A / 24 VA-for all 8 outputs	
	*) 250 mA / 6 VA per output if only 4 outputs per module are used	
	Max. Switch-on current per output	500mA / 12 VA for max. 90 s
Signal cables	Cable material	Solid or stranded copper wire
	Cable cross section	See manual CM110562
	Permitted cable length	max. 300 m
AC output (Terminals 2, 6, 10, 14, 19, 23, 27, 31)	Voltage	Ac 24 V
	Fuse	T 10A, in power supply module / bus connection module



Caution! Use cable cross section suited for 10 A according to local regulations.

Connection terminals	Mechanical design	Rising cage terminals
	Wire	1 x 0.5 mm ² to 4mm ² or 2 x 0,6 mmØ to 1.5 mm ²
	Copper stranded wire without ferrules	1 x 0.5 mm ² to 2.5 mm ² or 2 x 0,6 mmØ to 1.5 mm ²
	Stranded wire with ferrule (DIN 46228/1)	1 x 0.25 mm ² to 2.5 mm ² or 2 x 0,6 mmØ to 1.5 mm ²
⚠ Caution!	Use cable cross section suited for 10 A according to local regulations.	
	Screwdriver	No. 1 Screwdriver for slotted or recessed-head * screws <i>with shaft diameter ≤ 4.5 mm</i> * Combined slotted / recessed-head screws from mid-2012
Test plug socket (test terminals)	Max. tightening torque	0.6 Nm
	Pin diameter	1 x 1.8 to 2.0 mm
Classification per EN 60730	Operation of automatic controller	Type 1
	Degree of pollution	2
	Mechanical design	Safety classes III
Housing protection type	Degree of protection as per EN 60529	
	Front parts in DIN excerpt	IP30
	Terminal part	IP20
Environmental conditions	Operation	As per IEC/EN 60721-3-3
	Climatic conditions	Class 3K23
	Temperature	-5...50 °C
	Relative humidity	5...95% r.h.
	Mechanical conditions	Class 3M11
	Transport / storage	As per IEC/EN 60721-3-2 / -3-1
	Climatic conditions	Class 2K12 / 1K22
	Temperature	-25...70 °C
	Relative humidity	5...95% r.h.
	Mechanical conditions	Class 2M4
Standards, directives and approvals	Product standard	EN 60730-1
	Electromagnetic compatibility (Applications)	Automatic electrical controls for household and similar use For use in residential, commercial, light-industrial and industrial environments
	EU conformity (CE)	See EU declaration of conformity*)
	UL certification (US)	UL 916, http://ul.com/database
	RCM-conformity (EMC)	See RCM declaration of conformity*)
	EAC conformity	Eurasia conformity
Environmental compatibility	Product environmental declaration (contains data on RoHS compliance, materials composition, packaging, environmental benefit, disposal)	CM2E8179 *)
Color	Plug-in I/O module and terminal base top	2003 Ti-Grey
	Terminal base bottom	804 Black
Dimensions	Housing as per DIN 43880, see dimensions	
Weight	With/without packaging	178 / 199 g

*) The documents can be downloaded from <http://siemens.com/bt/download>.

Connection diagrams (example)

Terminal assignment

	TXM1.8T							
Output	(1)	(2)	(3)	(4)	(5)	(6)	(7)	(8)
AC 24 V supply *)	2	6	10	14	19	23	27	31
Switching output <i>The triac closes the contact to ⊥ (system neutral)</i>	4	8	12	16	21	25	29	33

The load can be connected directly to the corresponding output terminals. No separate AC 24 V supply is required.

Permanent contact
BO Triac NO
BO Triac NC

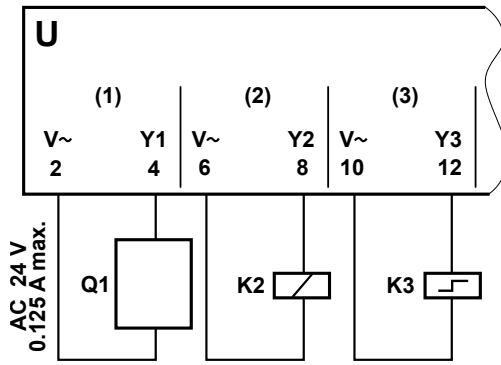

U Triac module

Q1 Switched load

(NO contact) AC 24 V

K2 Relay/Contactor AC 24 V

K3 Step switch /
Power surge relay /
bistable relay AC 24 V

Positioning signal 3-point
output
BO 3-Pos Triac

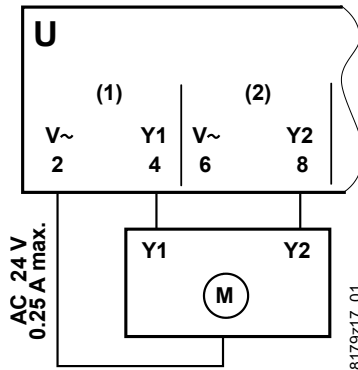

U Triac module

Y Motor-driven actuator AC 24 V
(valve, damper)

Y1 Positioning signal OPEN

Y2 Positioning signal CLOSE

AO PWM

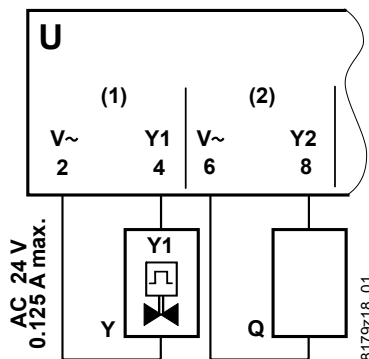

U Triac module

Y Thermal actuator AC 24 V
(valve)

Y1 PWM positioning signal

Q Switched load
(modulating PWM AC 24 V)

⚠ Caution!

*) On terminals 2, 6, 10, 14, 19, 23, 27, 31, use cable cross section suited for 10 A according to local regulations (T 10A fuse in the power supply module / bus connection module).

Dimensions

Dimensions in mm

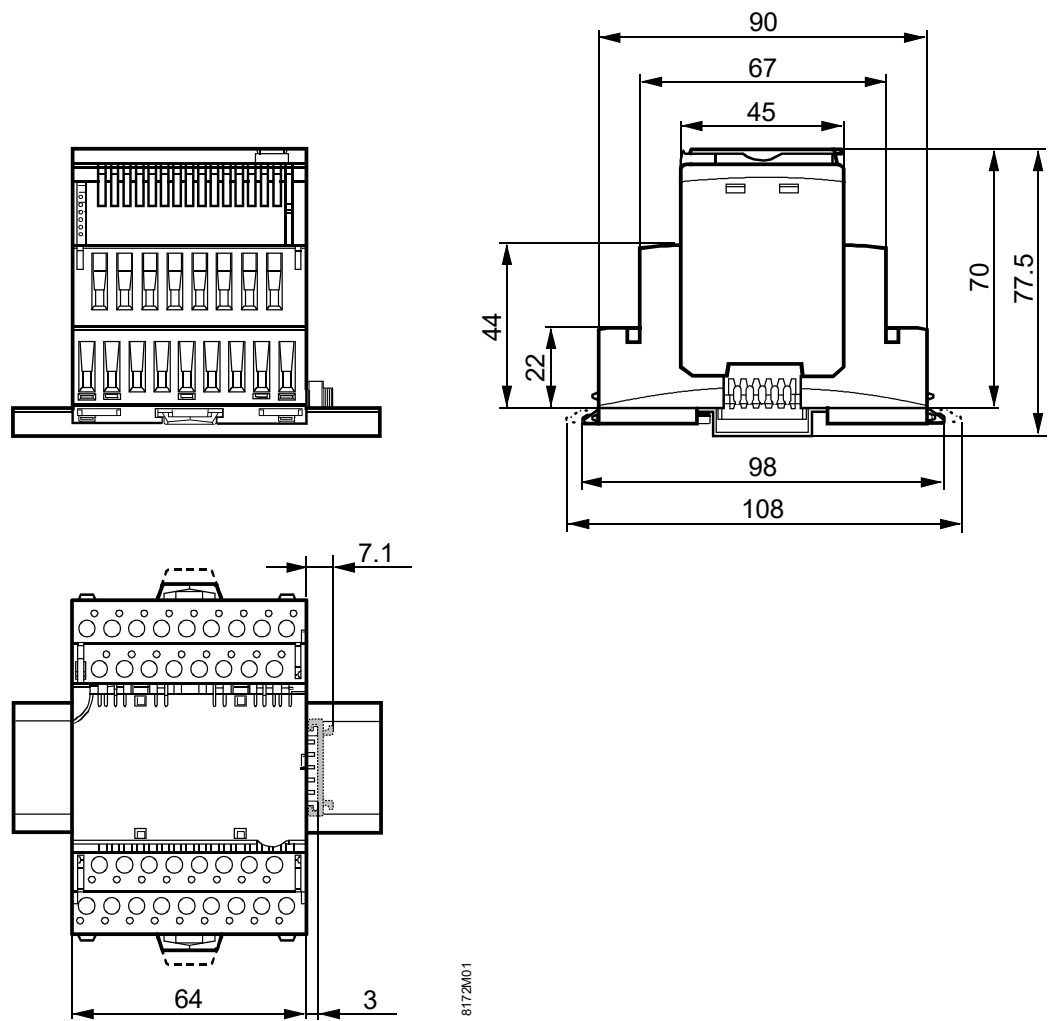

Published by:
Siemens Switzerland Ltd.
Smart Infrastructure
Global Headquarters
Theilerstrasse 1a
6300 Zug
Switzerland
Tel. +41 58-724 24 24
www.siemens.com/buildingtechnologies

© Siemens Switzerland Ltd 2012
Delivery and technical specifications subject to change