

## Busankoppler (BTM) UP 117/12 5WG1117-2AB12

## Bus Coupling Unit (BTM) UP 117/12 5WG1117-2AB12

## Bus kuplörü (BTM) UP 117/12 5WG1117-2AB12

## Bedien- und Montageanleitung Operating and Mounting Instructions Kullanım ve montaj kılavuzu

Stand: April 2020  
Issued: April 2020  
Güncelleme: Nisan 2020

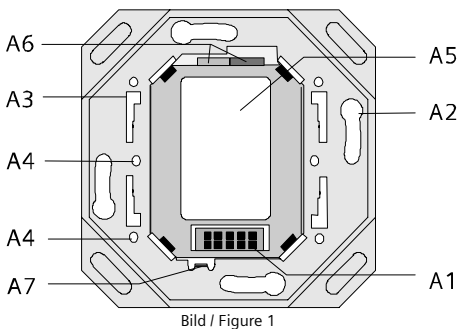
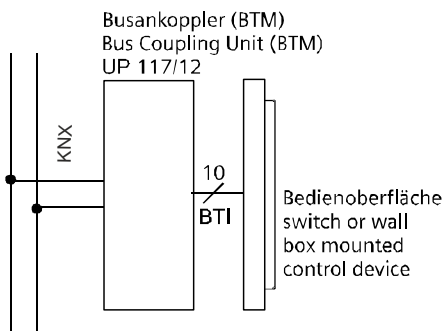

### Produkt- und Funktionsbeschreibung

Busankoppler (BTM) stellen für DELTA Bedienoberflächen mit Bus Transceiver Interface (BTI) Schnittstelle die Verbindung zum Bus her.

Ein Busankoppler (BTM) besitzt für die Montage auf UP-Dosen einen Hängebügel nach DIN/VDE.

Für den Busankoppler (BTM) gibt es kein Applikationsprogramm.

### Weitere Informationen

<http://www.siemens.de/gamma-td>

### Technische Daten

#### Spannungsversorgung

- Eingangsspannung
- Bus: DC 24V (DC 21...30V)

#### Ausgangsspannungen und -ströme an BTI

- DC 5V, 10mA
- DC 20V, 25mA

#### Anschlüsse

- Buslinie: Busklemme schraubenlos 0,6 ... 0,8 mm Ø eindrätig
- 10-polige Stiftleiste (BTI): zum Aufstecken von DELTA Bedienoberflächen mit BTI Schnittstelle

#### Mechanische Daten

- Abmessungen (L x B x T): 45,5 x 50 x 17,9 mm
- Gewicht: ca. 45 g
- Montage: wird mit dem Hängebügel auf der UP-Dose befestigt

#### Elektrische Sicherheit

- Schutzart (nach EN 60529): IP 20

#### Umweltbedingungen

- Umgebungstemperatur im Betrieb: - 5 ... + 45 °C
- Lagertemperatur: - 25 ... + 70 °C
- rel. Feuchte (nicht kondensierend): 5 % bis 93 %

### Lage- und Funktion der Anzeige- und Bedienelemente

(siehe Bild 1)

- A1 Bus Transceiver Interface (BTI) Buchse zum Anschluss von Busendgeräten mit BTI Stecker
- A2 Langlöcher für die Befestigung des Busankopplers (BTM) an der Installationsdose
- A3 Schlitz für die Befestigung des Busendgerätes mittels Führung und Befestigungsklammern
- A4 Gewinde für Befestigungsschrauben (für die zusätzliche Befestigung des Busendgerätes, z.B. Diebstahlschutz)
- A5 Typenschild
- A6 Busklemme für eindrätige Leiter mit 0,6 ... 0,8mm Ø
- A7 Erdungslasche

### Product and Applications Description

Bus Coupling Units (BTM) provide the connection to the bus for DELTA switches and wall box mounted control devices with Bus Transceiver Interface (BTI).

The Bus Coupling Unit (BTM) comes with a mounting frame for DIN/VDE type wall boxes.

The Bus Coupling Unit (BTM) does not require an application program.

### Additional Information

<http://www.siemens.de/gamma-td>

### Technical specifications

#### Power supply

- Input voltage
- Bus: DC 24V (DC 21...30V)

#### Output voltage and current via BTI

- DC 5V, 10mA
- DC 20V, 25mA

#### Connections

- Bus line : screwless bus connection block (red-black) 0.6...0.8 mm Ø single core
- 10-pin socket (BTI): for connection of DELTA switches and wall box mounted control devices with BTI plug

#### Physical specifications

- dimensions (L x W x D): 45,5 x 50 x 17,9 mm
- weight: approx. 45 g
- installation: mounted with mounting frame on DIN/VDE type wall boxes

#### Electrical safety

- protection (according to EN 60529): IP 20

#### Environmental specifications

- ambient temperature operating: -5...+ 45 °C
- storage temperature:-25 ... + 70 °C
- relative humidity (non-condensing): 5 % bis 93 %

### Location / Function of the Display and Operating Elements

(see figure 1)

- A1 Bus Transceiver Interface (BTI) socket for connecting an application unit with BTI plug
- A2 Slots for attaching the Bus Coupling Unit (BTM) to wall boxes
- A3 Slots for mounting application unit with guide and mounting clamps
- A4 Thread for mounting screws (for additional support, e.g. for securing the application unit against theft)
- A5 Type plate
- A6 Bus connection block for single core conductors with Ø 0.6 ... 0.8 mm
- A7 earthing plate



Bild / Figure 2



Bild / Figure 3

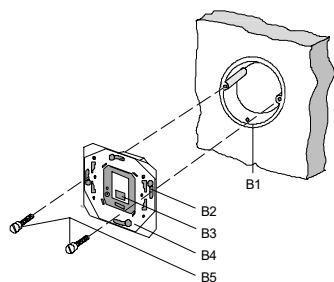

Bild / Figure 4

#### Electromagnetic compatibility

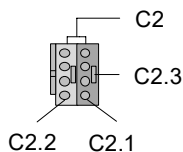
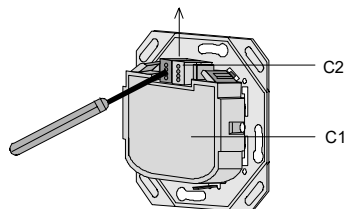
##### USA:

This device complies with part 15 of the FCC Rules. Operation is subject to the following two conditions:

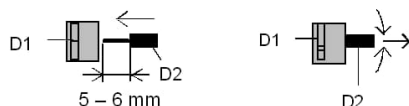
- (1) This device may not cause harmful interference, and
- (2) this device must accept any interference received, including interference that may cause undesired operation.

This equipment has been tested and found to comply with the limits for a Class B digital device, pursuant to part 15 of the FCC Rules. These limits are designed to provide reasonable protection against harmful interference in a residential installation. This equipment generates, uses and can radiate radio frequency energy and, if not installed and used in accordance with the instructions, may cause harmful interference to radio communications. However, there is no guarantee that interference will not occur in a particular installation. If this equipment does cause harmful interference to radio or television reception, which can be determined by turning the equipment off and on, the user is encouraged to try to correct the interference by one or more of the following measures:

- Reorient or relocate the receiving antenna.
- Increase the separation between the equipment and receiver.
- Connect the equipment into an outlet on a circuit different from that to which the receiver is connected.
- Consult the dealer or an experienced radio/TV technician for help.

This device complies with Part 15 of the FCC rules. Changes or modifications not expressly approved by Siemens Schweiz AG could void the user's authority to operate the equipment.

##### United States representative:

<https://new.siemens.com/us/en/products/buildingtechnologies/home.html>

##### Canada:

CAN ICES-3(B)/NMB-3(B)

#### Technical Support

+49 (911) 895-7222

+49 (911) 895-7223

support.automation@siemens.com

[www.siemens.de/automation/support-request](http://www.siemens.de/automation/support-request)

#### Montage und Verdrahtung

##### Allgemeine Beschreibung

Der Anschluss an die Buslinie erfolgt über die Busklemme 193 (schraubenlose Steckklemmen für eindrähtige Leiter). Die Busendgeräte werden mittels Führungs- und Befestigungsfedern auf den Busankoppler (BTM) aufgesteckt und je nach Bauart durch Schrauben befestigt.

##### Hinweis

Der Busankoppler (BTM) ist so zu montieren, dass sich das Bus Transceiver Interface (BTI) unten befindet (Bild 2). Dadurch ist sichergestellt, dass die auf die BTI aufzusteckenden Busendgeräte, in der für die Bedienung richtigen Lage montiert werden. Für eine dauerhaft sichere Kontaktgabe an der BTI wird dringend empfohlen, nur Busendgeräte mit Befestigungsschrauben zu verwenden.

#### Montage

(siehe Bild 2)

- B1 Installationsdose (60mm Ø nach DIN 49073)
- B2 Langlöcher zur Befestigung
- B3 Bus Transceiver Interface (BTI)
- B4 Busankoppler (BTM)
- B5 Befestigungsschrauben

##### Busklemme abziehen/aufstecken (Bild 3)

Die Busklemme (C2) befindet sich auf der Rückseite des Busankopplers (BTM) (C1). Die Busklemme (C2) besteht aus zwei Teilen (C2.1, C2.2) mit je vier Klemmkontakten. Es ist darauf zu achten, dass die beiden Prüfbuchsen (C2.3) weder mit dem Busleiter (versehentlicher Steckversuch) noch mit dem Schraubendreher (beim Versuch die Busklemme zu entfernen) beschädigt werden.

##### Busklemme abziehen (Bild 3)

- Den Schraubendreher vorsichtig in den Drahteinführungsschlitz des schwarzen Teils der Busklemme (C2.2) einführen und
- die Busklemme (C2) aus dem Busankoppler (BTM) (C1) herausziehen.

##### Hinweis

Busklemme nicht von unten heraushebeln! Kurzschlussgefahr!

##### Busklemme aufstecken (Bild 3)

- Die Busklemme in die Führungsnut des BTM (C1) stecken und
- die Busklemme bis zum Anschlag nach unten drücken.

##### Anschließen der Busleitung (Bild 4)

- Die Busklemme (D1) ist für eindrähtige Leiter mit 0,6 ... 0,8mm Ø geeignet.
- Den Leiter (D2) ca. 5mm abisolieren und in Klemme (D1) stecken (rot = +, grau = -)

##### Abklemmen der Busleitung (Bild 4)

- Die Busklemme (D1) abziehen und den Leiter (D2) der Busleitung, bei gleichzeitigem Hin- und Herdrehen, herausziehen.

#### Installationshinweise

- Das Gerät kann für feste Installation in Innenräumen, für trockene Räume, zum Einbau in UP-Dosen verwendet werden.



WARNUNG

- Das Gerät darf nur von einer zugelassenen Elektrofachkraft installiert und in Betrieb genommen werden.
- Das Gerät darf nicht zusammen mit 230V Geräten und/oder 230V Leitungen in derselben Dose eingesetzt werden.
- Die geltenden Sicherheits- und Unfallverhütungsvorschriften sind zu beachten.
- Das Gerät darf nicht geöffnet werden.
- Bei der Planung und Errichtung von elektrischen Anlagen sind die einschlägigen Richtlinien, Vorschriften und Bestimmungen des jeweiligen Landes zu beachten.

#### Allgemeine Hinweise

- Die Bedienungsanleitung ist dem Kunden auszuhändigen.
- Ein defektes Gerät ist mit einem Rücklieferschein der zuständigen Vertriebsniederlassung zurückzusenden.
- Bei zusätzlichen Fragen zum Produkt wenden Sie sich bitte an unseren Technical Support.

#### Mounting and wiring

##### General description

The connection to the bus line is established via bus connection block 193 (screwless plug-in terminals for single core conductors). The application unit is slipped onto the bus coupling unit (BTM) via guide and mounting clamps and, depending on the device type, fastened with screws.

##### Note

The Bus Coupling Unit (BTM) must be mounted with the Bus Transceiver Interface (BTI) situated at the bottom (see Figure 2). Thus, the application unit will be oriented properly when slid onto the BTI. Use bus devices with mounting screws only to achieve a permanently stable contact at the BTI.

#### Mounting

(see figure 2)

- B1 wall box (60 mm Ø, according to DIN 49073)
- B2 mounting slots
- B3 Bus Transceiver Interface (BTI)
- B4 Bus coupling unit (BTM)
- B5 mounting screws

##### Slipping off/on bus connection blocks (figure 3)

The bus connection block (C2) is situated on the back of the bus coupling unit (BTM) (C1). It consists of two components (C2.1 and C2.2) with four terminal contacts each. Take care not to damage the two test sockets (C2.3) by accidentally connecting them to the bus cable or with the screw driver (e.g. when attempting to unplug the bus connection block).

##### Slipping off bus connection blocks (figure 3)

- Carefully put the screw driver to the wire insertion slit of the bus connection block's grey component (C2.2) and
- pull the bus connection block (C2) from the bus coupling unit (BTM) (C1).

##### Note

Don't try to remove the bus connection block from the bottom side. There is a risk of shorting-out the device!

##### Slipping on bus connection blocks (figure 3)

- Slip the bus connection block (C2) onto the guide slot of the BTM (C1) and
- press the bus connection block (C2) down to the stop.

##### Connecting bus cables (figure 4)

- The bus connection block (D1) can be used with single core conductors Ø 0.6...0.8 mm.
- Remove approx. 5 mm of insulation from the conductor (D2) and plug it into the bus connection block (D1) (red = +, grey = -)

##### Disconnecting bus cables (figure 4)

- Unplug the bus connection block (D1) and remove the bus cable conductor (D2) while simultaneously wiggling it.

#### Installation notes

- The device can be used for permanent installation in dry interior rooms, for mounting in wall boxes.



WARNUNG

- The device must be mounted and commissioned by an authorized electrician.
- The device must not be mounted in wall boxes together with 230 V devices and/or 230 V cables.
- The prevailing safety rules must be heeded.
- The device must not be opened.
- For planning and construction of electrical installations, the relevant guidelines, regulations and standards of the respective country are to be considered.

#### General Notes

- The operating instructions must be handed over to the client.
- A faulty device shall be returned with a Return Good Note for Service provided by the appropriate Siemens sales office.
- If you have further questions concerning the product please contact our technical support.

# TR

## Ürün ve fonksiyon açıklaması

Bus kabloları (BTM), Bus Transceiver Interface (BTI) arabirimine sahip DELTA kullanıcı arayüzleri için bus bağlantısını oluşturur. Bus kabloları (BTM) sıva altı kutuların üzerine montaj için DIN/VDE standardına uygun braketle sahiptir.

Bus kabloları (BTM) için uygulama programı gerekli değildir.

## Daha fazla bilgi

<http://www.siemens.de/gamma-td>

## Teknik veriler

### Güç kaynağı

Giriş gerilimi

- Bus: DC 24V (DC 21...30V)

### BTI çıkış gerilimleri ve akımları

- DC 5V, 10mA
- DC 20V, 25mA

### Bağlantılar

- Bus hattı: Bus klemensi vidasız 0,6 ... 0,8 mm Ø tek telli
- 10 pinli soket (BTI): BTI arabirimli DELTA kullanıcı arayüzlerini takmak için kullanılır

### Mekanik veriler

- Ölçüler (U x G x D): 45,5 x 50 x 17,9 mm
- Ağırlık: yakl. 45 g
- Montaj: Braket ile sıva altı kutu üzerine sabitlenir

### Elektrik güvenliği

- Koruma türü (EN 60529 uyarınca): IP 20

### Çevre koşulları

- İşletimde ortam sıcaklığı: - 5 ... + 45 °C
- Depolama sıcaklığı: - 25 ... + 70 °C
- Bağıl nem (yoğuşmasız): %5 - %93

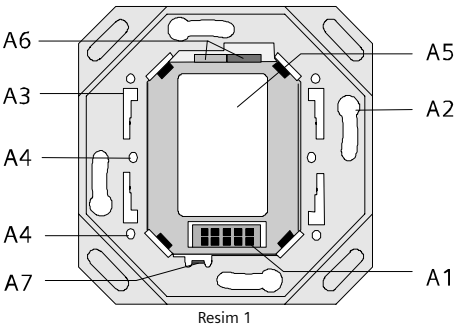
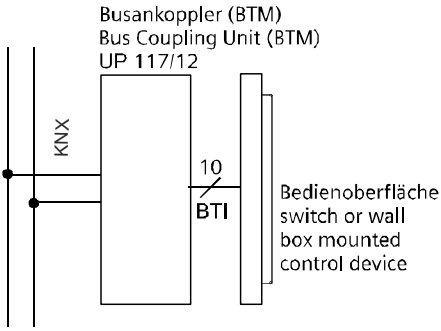

## Gösterge ve kontrol elemanlarının konumu ve fonksiyonu

(Bkz. resim 1)

- A8 BTI soketli bus cihazlarının bağlanması için Bus Transceiver Interface (BTI)
- A9 Bus kablolarının (BTM) kurulum kutusuna sabitlenmesi için uzun delikler
- A10 Bus cihazını kılavuz ve sabitleme kışacları ile sabitlemek için delikler
- A11 Sabitleme civataları için vida dişi (hırsızlık emniyeti vs. gibi ek bus cihazlarını sabitlemek için)
- A12 Tip etiketi
- A13 0,6 ... 0,8mm Ø çapında tek telli iletkenler için bus klemensi
- A14 Topraklama plakası

# TR

## Montaj ve kablo bağlantısı

### Genel açıklama

Bus hattı bağlantısı, bus klemensi 193 üzerinden sağlanır (tek telli iletkenler için vidasız geçmeli klemensler). Bus cihazları kılavuz ve sabitleme yayları ile bus kablörüne (BTM) takılır ve tipe bağlı olarak vidalarla sabitlenir.

### Not

Bus kablörü (BTM), Bus Transceiver Interface (BTI) altına kalacak şekilde monte edilmelidir (resim 2). Bu şekilde, BTI üzerine takılacak bus cihazlarının kullanım için doğru konumda monte edilmesi sağlanır. BTI üzerinde güvenli kontak oluşturmak için, mutlaka sadece sabitleme civatalı bus cihazlarının kullanılması önerilir.

## Montaj

(Bkz. resim 2)

- B6 Kurulum kutusu (DIN 49073 uyarınca 60mm Ø)
- B7 Sabitlemek için uzun delikler
- B8 Bus Transceiver Interface (BTI)
- B9 Bus kablörü (BTM)
- B10 Sabitleme civataları

### Bus klemensinin çıkartılması/takılması (resim 3)

Bus klemensi (C2) bus kablörünün (BTM) arka tarafında bulunur (C1).

Bus klemensi (C2) iki parçadan (C2.1, C2.2) ve dörder klemens kantağından oluşur. İki kontrol girişine (C2.3) bus iletkeni (yanlışlıkla takmaya çalışma) veya tornavida (bus klemensini çıkarmaya çalışma) ile zarar verilmemesine dikkat edilmelidir.

### Bus klemensinin çıkartılması (resim 3)

- Tornavida, bus klemensindeki (C2.2) siyah parçanın tel giriş açıklığına dikkatlice yerleştirilmeli ve
- Bus klemensi (C2) bus kablöründen (BTM) (C1) dışarı çekilmelidir.

### Not

Bus klemensini alttan kanırtmayın! Kısa devre tehlikesi!

### Bus klemensinin takılması (resim 3)

- Bus klemensini BTM (C1) kılavuz kanalına takın ve
- Bus klemensini oturana kadar aşağı bastırın.

### Bus kablösünün bağlanması (resim 4)

- Bus klemensi (D1), çapı 0,6 ... 0,8mm Ø olan tek telli iletkenler için uygundur.
- İletkeni (D2) yaklaşık 5 mm sıyırın ve klemense (D1) takın (kırmızı = +, gri = -)

### Bus kablösünün sökülmesi (resim 4)

- Bus klemensini (D1) çekin ve bus kablösünün iletkenini (D2) ileri geri çevirerek dışarı çekin.

## Kurulum uyarıları

- Cihaz, kuru ve kapalı alanlarda sıva altı kutulara sabit montaj için öngörülmüştür.



### UYARI

- Cihaz, sadece yetkili uzman elektrik personeli tarafından monte edilmeli ve işleme alınmalıdır.
- Cihaz, 230V cihazlar ve/veya 230V kablolar ile aynı kutu içinde kullanılmamalıdır.
- Geçerli güvenlik ve kaza önleme yönetmelikleri dikkate alınmalıdır.
- Cihazın içi açılmamalıdır.
- Elektrik tesisatlarını planlama ve kurulum aşamasında, ilgili ülkede geçerli olan yönetmelikler, talimatlar ve yasalar dikkate alınmalıdır.

## Genel uyarılar

- Kullanım kılavuzu müşteriye teslim edilmelidir.
- Anzalı cihazlar, yetkili satış şubesinin iade belgesi ile geri gönderilmelidir.
- Ürün ile ilgili sorularınız için lütfen teknik destek ekibimize başvurun.

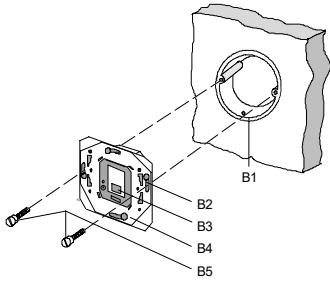

Resim 2

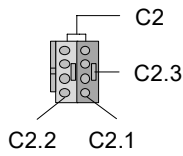
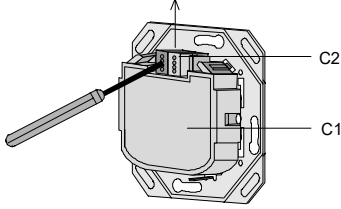

Resim 3

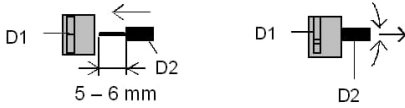

Resim 4

## Teknik destek

+49 (911) 895-7222

+49 (911) 895-7223

support.automation@siemens.com

www.siemens.de/automation/support-request