

SIEMENS

INSTALLATION INSTRUCTIONS

Model VTO2001-U2/U3

Option Module (24 Switches)

The Model VTO2001-U2/U3 Option Module (24 Switches) illustrated in Figure 1 is installed in the FV2025/2050 Fire Voice Control System and the VR2005-U1 Remote Microphone station to provide pushbutton controls and LED status indicators for the programmable system control functions.

NOTE: The VTO2001-U2/U3 is intended for use in dry, protected environments, only.

FEATURES

The principal features of the VTO2001-U2/U3 Option Module (24 Switches) include:

- 24 illuminated pushbutton controls and 96 multi-color LED status indicators
- Modules are individually addressable
- Remote firmware update capability for the on-board microcontroller
- Audio feedback confirms pushbutton operation
- All tri-color LEDs can be OFF, flashing or steady-ON
- CAN bus data transfer
- EMC compliant
- ROHS compliant and meets performance specifications within the temperature range
- Can be used in the UL and ULC markets

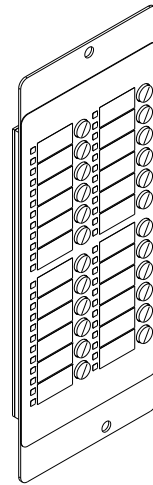

Figure 1
VTO2001-U2/U3 Option
Module (24 Switches)

PRE-INSTALLATION

Programming the CAN Bus Address

The two digit CAN Bus address for the VTO2001-U2/U3 Option Module (24 Switches) is determined by the two rotary DIP switches located on the back of the module, as illustrated in Figure 2. The left switch sets the tens digit of the address while the right switch sets the ones digit of the address. The CAN bus address for each module is selected by the installer and may be set either before or after mounting the module in the FV2025/2050 Fire Voice Control Panel or the VR2005-U1 Remote Microphone station. However, to simplify addressing and avoid errors, it is recommended that the module address be set after the module is mounted in the Panel. To set the CAN Bus address use a small flat bladed screwdriver to rotate the center of each switch until the arrow points to the digit of the address which that switch represents.

NOTE: CAN Bus addresses 1 - 5 are reserved for the VCI2001-U1 Voice Amplifiers and are not available for option modules.

Configuring the Pushbuttons

Each VTO2001-U2/U3 Option Module (24 Switches) must be configured before operating the host FV2025/2050 Fire Voice Control Panel or VR2005-U1 Remote Microphone station. This configuring is accomplished with the aid of the FS20 Engineering Tool, as described in Siemens Industry, Inc., Building

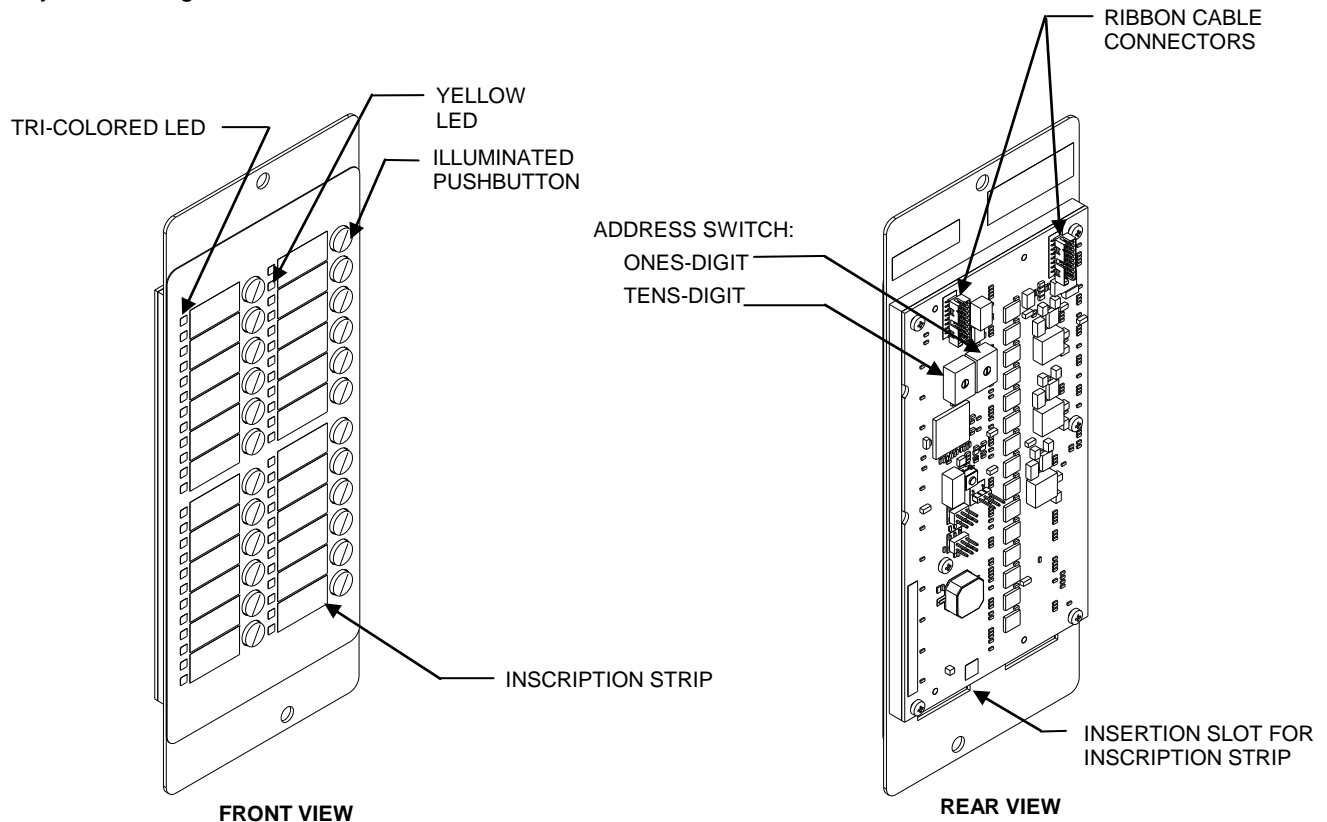

Figure 2
VTO2001-U2/U3 Option Module (24 Switches)

OPERATION

The VTO2001-U2/U3 Option Module (24 Switches) provides a series of programmable pushbuttons to control specific fire alarm and suppression functions in up to 24 fire zones. The yellow and the tri-colored LED mounted to the left of each pushbutton indicate the status of the function controlled by the pushbutton (see Figure 2). An audio signal is generated when a button is pressed to indicate that the module has recognized that action. A label located between each pushbutton and its indicator LEDs identifies the pushbutton function. When an installation includes more than 24 fire zones, a number of VTO2001 modules can be combined to provide the required number of pushbutton controls and LED indicators.

Controls and Indicators

The purpose of each VTO2001-U2/U3 pushbutton and the meaning of the indicator lights are covered in Siemens document A6V10315023 FS20 Fire Detection and Voice Announcement System Configuration Manual.

MOUNTING



Remove electrical power prior to working on equipment.

The VTO2001-U2/U3 Option Module (24 Switches) is mounted on the inner door in both the FV2025/2050 Fire Voice Control Panel and the VR2005-U1 Remote Microphone station.

1. Open the outer and inner doors of the FV2025/2050 Fire Voice Control Panel or the VR2005-U1 Remote Microphone station.
 - a. **FV2025/2050 Fire Voice Control Panel.** Please see Figure 3. Consult the site-specific shop drawings to determine how many VTO2001-U2/3 Option Module (24 Switches) modules to mount in the middle and bottom windows of the FV2025/2050 Fire Voice Control Panel.

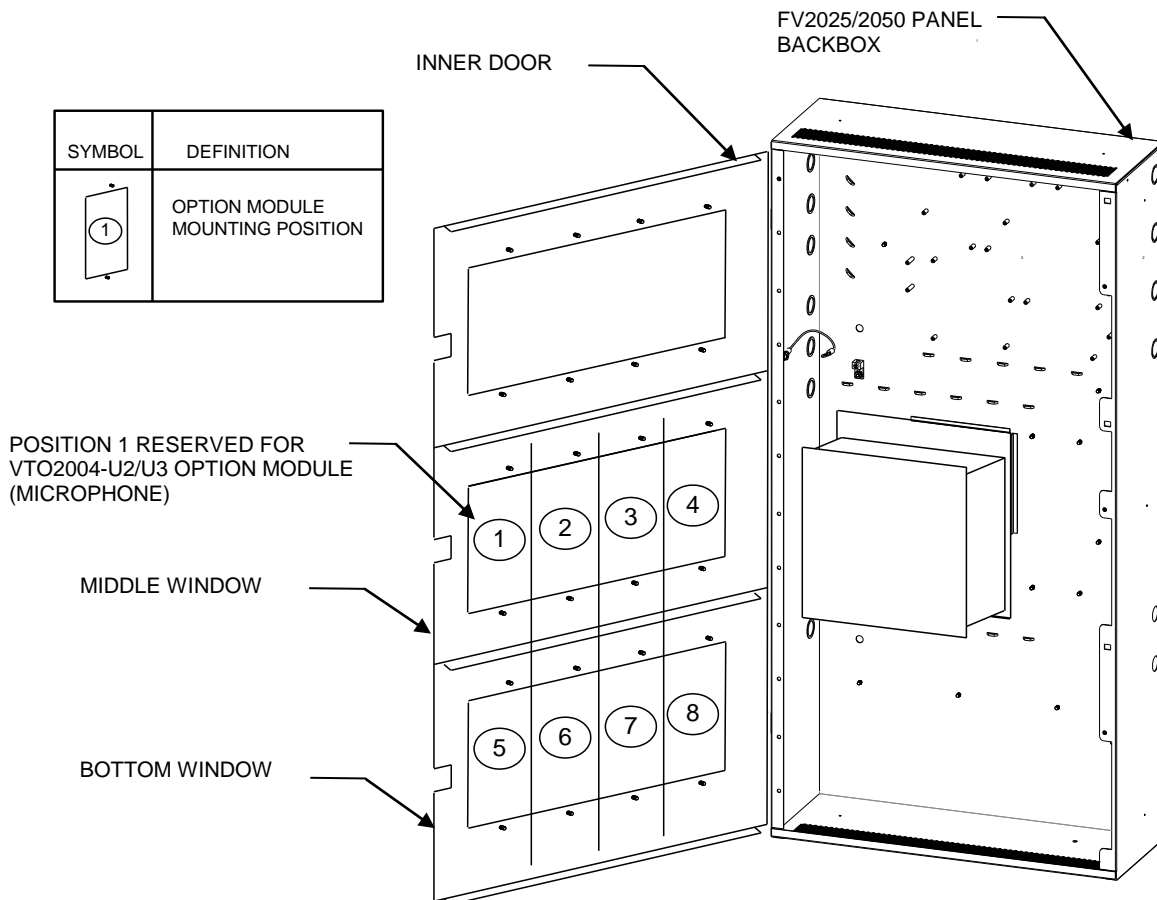

Figure 3
Option Module Mounting Positions on the FV2025/2050 Fire Voice Control Panel Inner Door

- b. **VR2005-U1 Remote Microphone.** Please see Figure 4. Consult the site-specific shop drawings to determine how many VTO2001-U2/3 Option Module (24 Switches) units to mount in the VR2005-U1 Remote Microphone station.

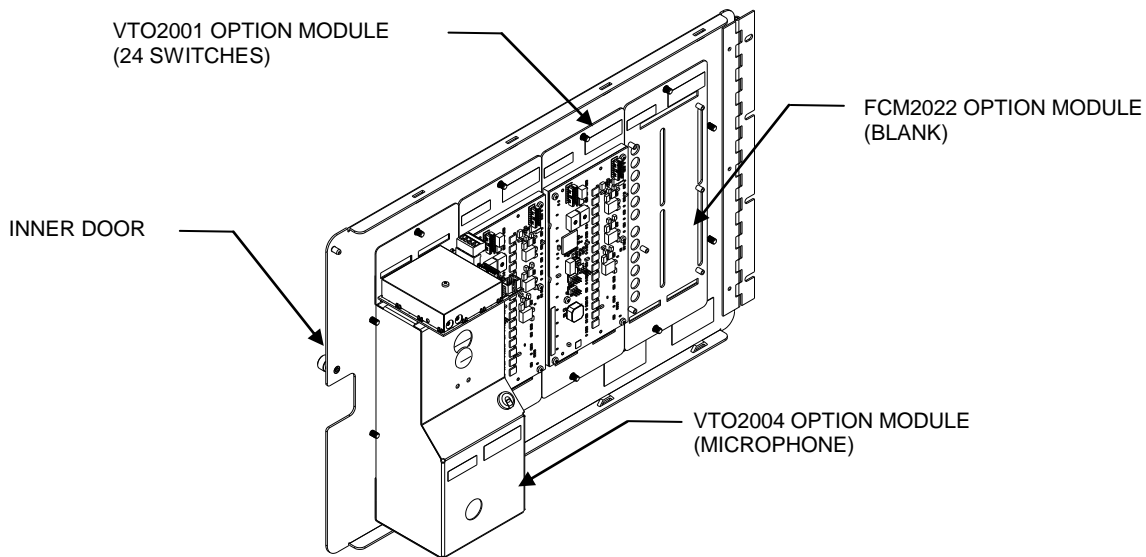

Figure 4
Option Modules Mounted in the VR2005-U1 Remote Microphone Station

NOTE: An FCM2022 Option Module (blank) must be installed in any unoccupied mounting position of the inner door of the FV2025/2050 Fire Voice Control Panel or the V2005-U1 Remote Microphone station.

2. Please see Figure 5. Mount each option module in its assigned position by sliding its top and bottom mounting holes over the upper and lower mounting studs on the inside surface of the inner door.
3. Use two #10-32 nuts to secure each option module to the inner door.
4. Install FCM2022 blanks, if needed, in any module mounting positions not occupied by a VTO2001-U2/U3 Option Module (24 Switches) or a VTO2004-U2/U3 Option Module (Microphone).

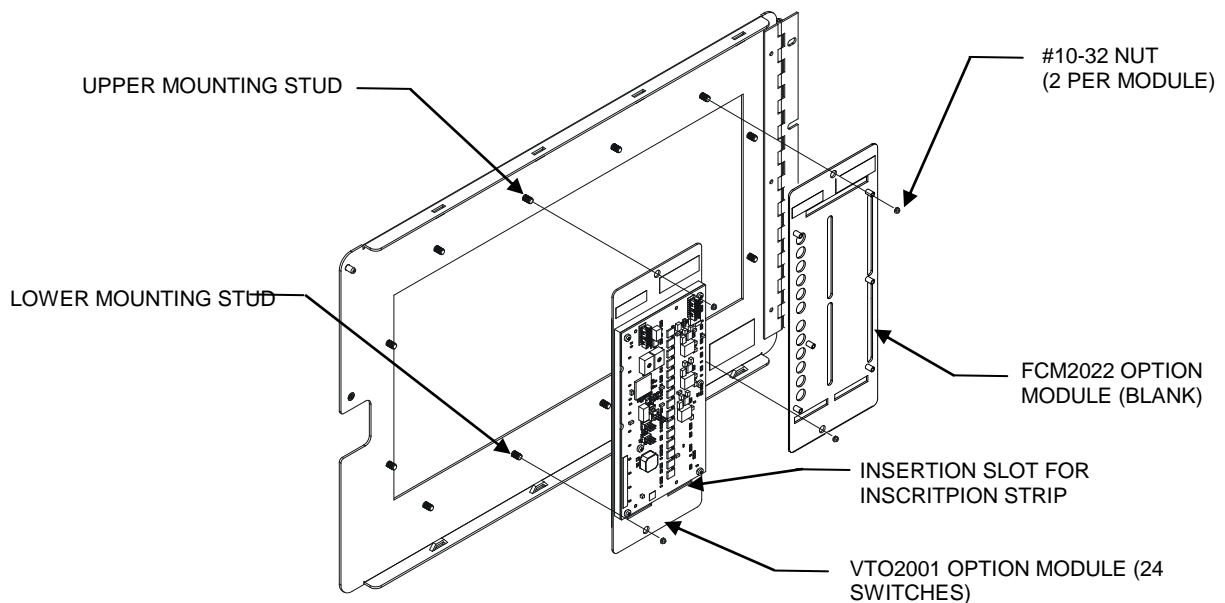

Figure 5
Mounting the VTO2001-U2/U3 and the FCM2022 Option Module (Blank)

Installing the Inscription Strips on the VTO2001-U2/U3

Insert paper inscription strips into the left and right slots provided on the bottom-rear of the VTO2001-U2/U3 module to identify the programmable functions associated with each control pushbutton. The insertion slots on the rear of the VTO2001-U2/U3 module are illustrated in Figure 5.

The inscription strips are normally printed during the panel configuration process (detailed in Siemens Industry, Inc., Building Technologies Division, document number A6V10315023 [FS20 Fire Detection and Voice Announcement System; Configuration Manual](#).) Templates for printing the inscription strips are provided in Siemens document A6V10321358 [FS20 Fire Detection System; Inscription Strips](#).

WIRING

The VTO2001-U2/U3 Option Module (24 Switches) and the VTO2004-U2/U3 Option Module (Microphone) (if installed) are connected in “daisy-chain” style to connector X102 on the VCA2002-A1 Card Cage using the supplied 16-conductor ribbon cables. Part I, below, provides wiring instructions for the option modules when they are installed in the FV2025/2050 Fire Voice Control Panel. Part II provides instructions for wiring the option modules when they are installed in the VR2005-U1 Remote Microphone station.

NOTES:

1. To prevent cable damage, use stick-on cable supports to secure ribbon cables to the inner door of both the FV2025/2050 Fire Voice Control Panel and the VR2005-U1 Remote Microphone station.
2. All ribbon cables and jumpers required for this procedure are supplied in the installation kit furnished with the equipment.
3. Install all ribbon cables so that the red wire is connected to pin 1 of the mating board connector.

Part I. Wiring the VTO2001-U2/U3 Option Module (24 Switches) in the FV2025/2050 Panel

The ribbon cable routing will depend on whether any VTO2001-U2/U3 Option Module (24 Switches) are installed in the bottom window of the FV2025/2050 Panel's inner door:

- If there are no VTO2001-U2/U3 modules mounted in the bottom window, use Wiring Procedure 1A, below, and route the ribbon cables as illustrated in Figure 6.
- If one or more VTO2001-U2/U3 is mounted in the bottom window, use Wiring Procedure 1B, below, and route the ribbon cables as illustrated in Figure 8.

A. Wiring Procedure 1A: No VTO2001-U2/U3 modules mounted in the bottom window

1. Please see Figure 6. Install a 16-conductor ribbon cable between connector X102 located on the lower left corner of the backplane of the VCA2001-A1 Card Cage and connector X205 of the right-most VTO2001-U2/U3 module mounted in the middle window of the FV2025/2050 Panel's inner door.
2. Install ribbon cable jumpers to ‘daisy chain’ all VTO2001-U2/U3 modules mounted in the middle window, as illustrated in Figure 6.
3. If the last module on the left of the daisy-chain is a:
 - VTO2001-U2/U3 Option Module (24 Switches), install an A5Q00055918D End-of-Line (EoL) terminator as shown in Figure 7 in connector X204 of the VTO2001-U2/U3 Module and proceed to Part 2, below.
 - VTO2004-U2/U3 Option Module (Microphone) (as shown in Figure 6), refer to Siemens Industry, Inc., Building Technologies Division, document number A6V10370377 [Installation Instructions for the Model VTO2004-U2/U3 Option Module \(Microphone\)](#) for instructions on wiring the VTO2001-U2/U3 Module to the VTO2004-U2/U3 Module.

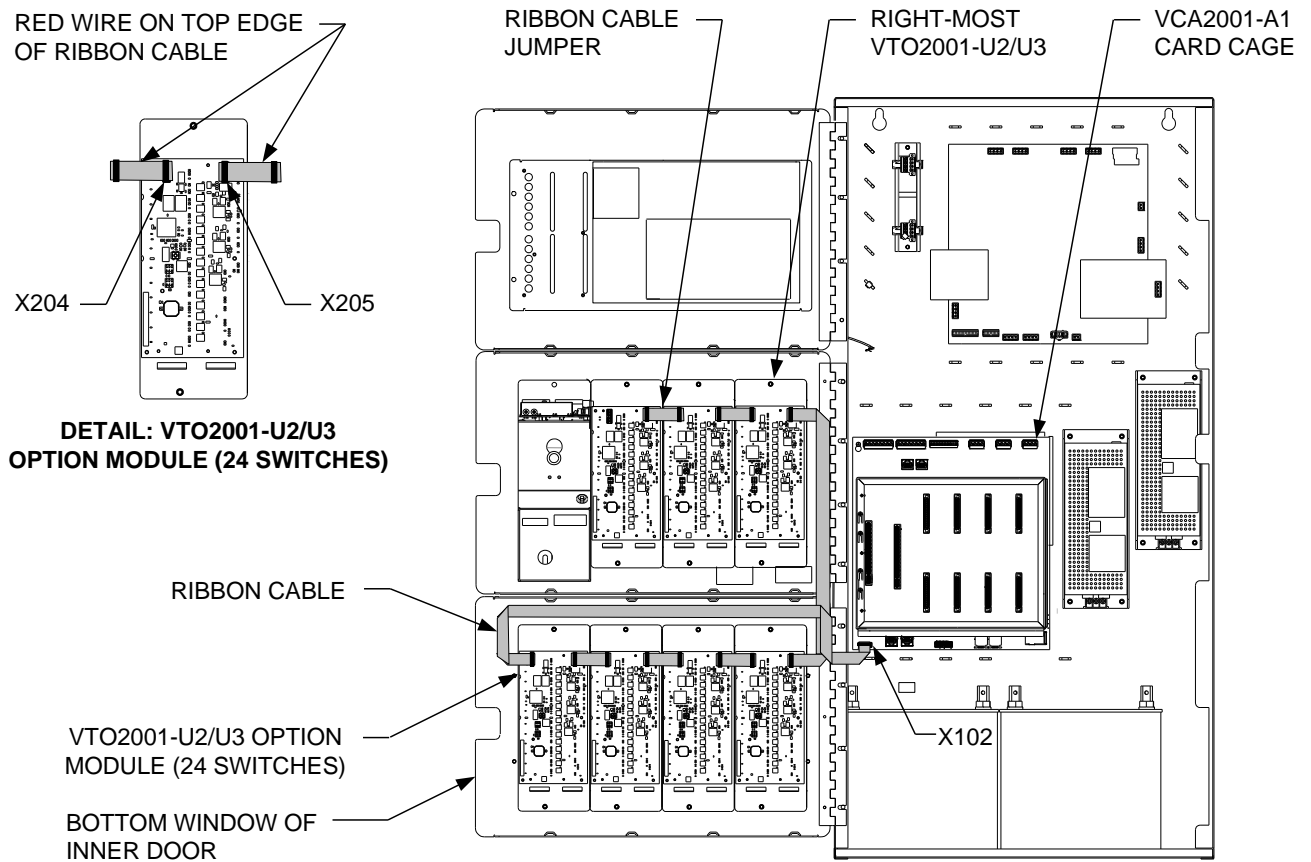

Figure 6
Using Procedure 1A to Wire the VTO2001-U2/U3 Modules in the FV2025/2050 Fire Voice Control Panel

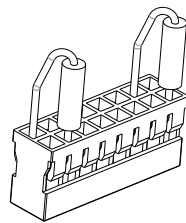

Figure 7
A5Q00055918D End-of-Line Terminator

B. Wiring Procedure IB: At least one VTO2001 U2/U3 module mounted in the bottom window

1. Please see Figure 8. Install a 16-conductor CAN ribbon cable between connector X102 located just below the VCA2001-A1 Card Cage and connector X204 of the left-most VTO2001-U2/U3 module in the bottom window of the FV2025/2050 Panel's inner door.
2. Install ribbon cable jumpers to 'daisy chain' all VTO2001-U2/U3 Option modules mounted in the bottom window, as illustrated in Figure 8.
3. Connect a CAN ribbon cable from connector X205 of the right-most VTO2001-U2/U3 module in the bottom window to connector X205 of the right-most VTO2001-U2/U3 module mounted above it in the middle window.

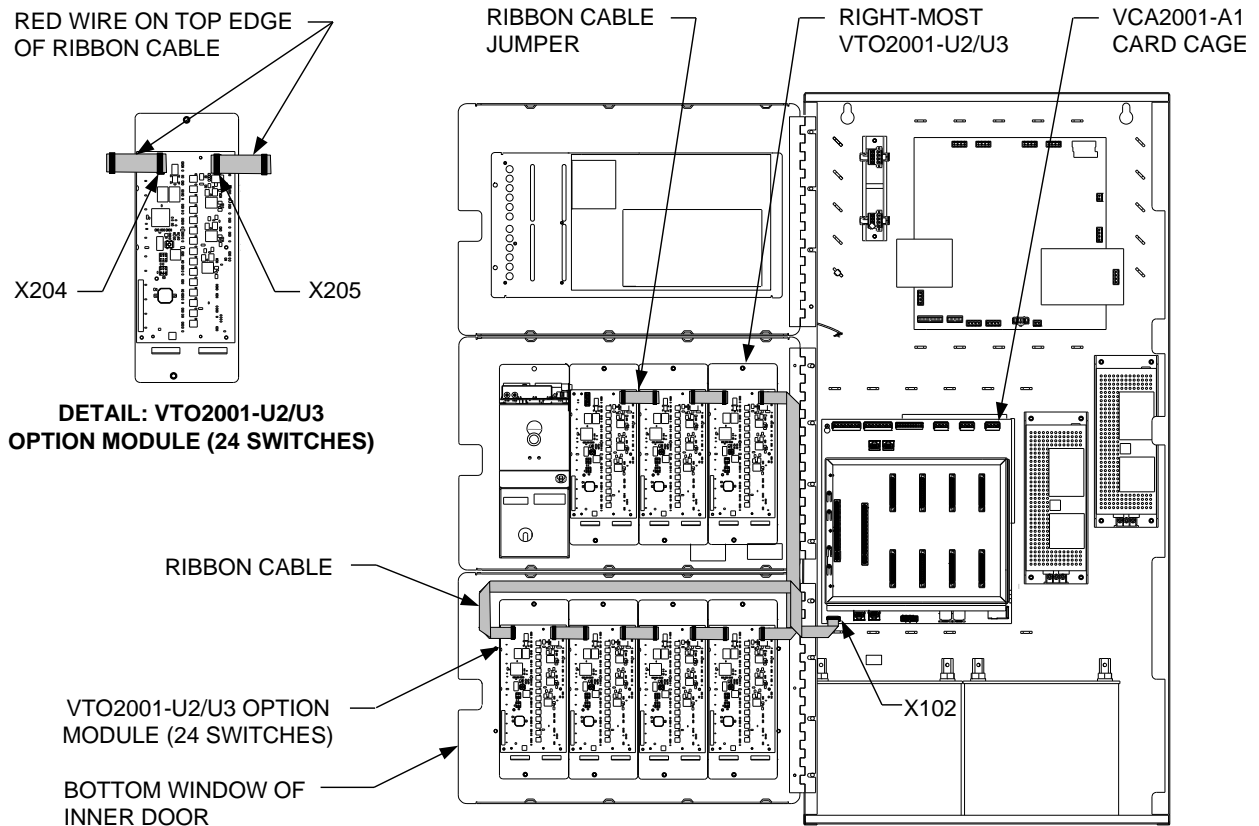

Figure 8
Using Procedure IB to Wire the VTO2001-U2/U3 Modules in the FV2025/2050 Fire Voice Control Panel

4. Install ribbon cable jumpers to 'daisy chain' all VTO2001-U2/U3 Option Module (24 Switches) modules mounted in the middle window, as illustrated in Figure 8.
5. If the last module on the left of the daisy-chain is a:
 - VTO2001-U2/U3 Option Module (24 Switches), install an A5Q00055918D EoL in connector X204 of the VTO2001-U2/U3 Module.
 - VTO2004-U2/U3 Option Module (Microphone) (as shown in Figure 8), refer to Siemens Industry, Inc., Building Technologies Division, document number A6V10370377 *Installation Instructions for the Model VTO2004-U2/U3 Option Module (Microphone)* for instructions on wiring the VTO2001-U2/U3 Module to the VTO2004-U2/U3 Module.

Part II. Wiring the VTO2001-U2/U3 Option Module (24 Switches) in the VR2005-U1 Remote Microphone Station

Please refer to Figure 9. Interconnect the VTO2001-U2/U3 Option Module (24 Switches) to the VTA2001-U1 Voice Terminal Board, as follows:

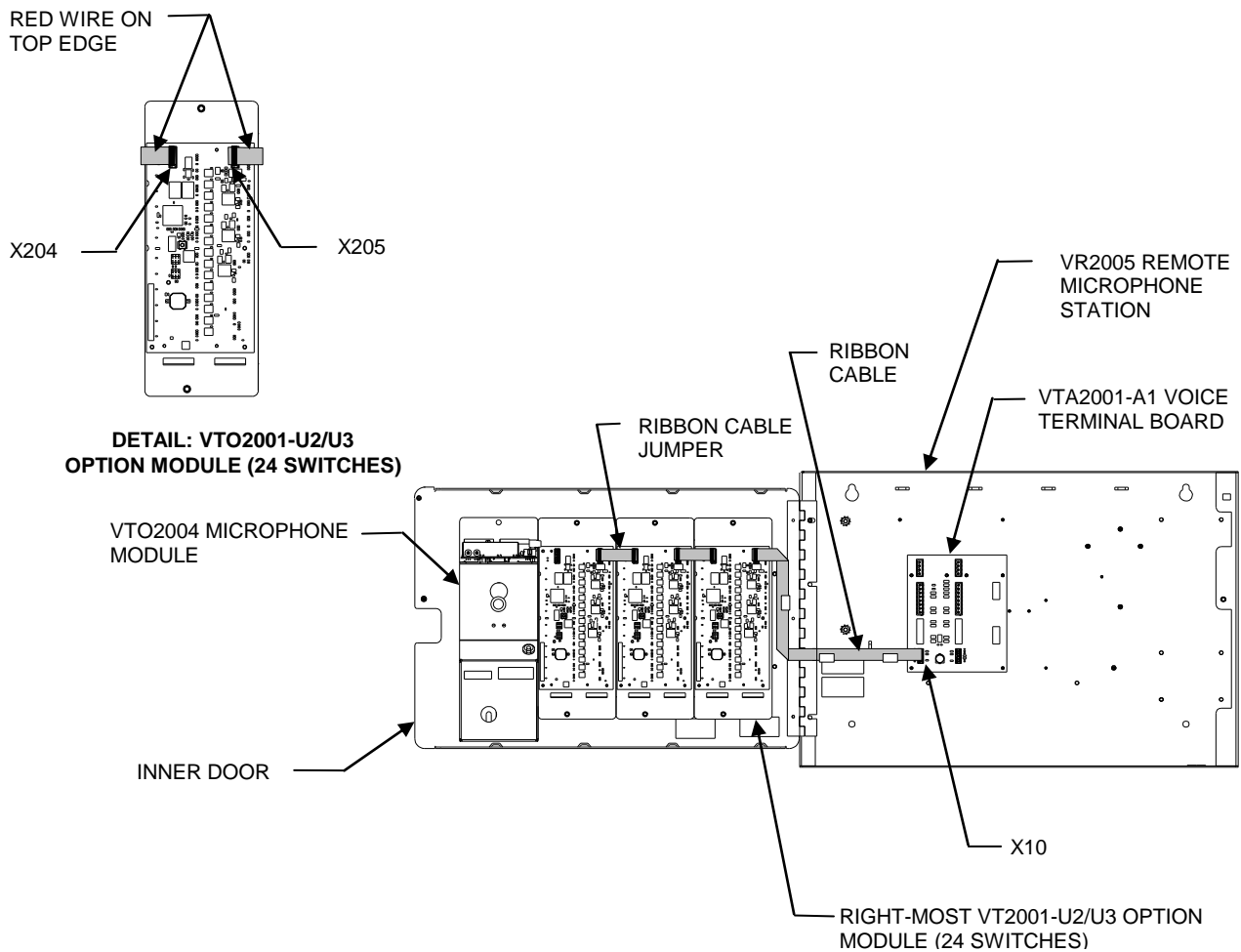

Figure 9
Wiring the VTO2001-U2/U3 Modules in the VR2005-U1 Remote Microphone Station

1. In the VR2005-U1 Remote Microphone station, install a ribbon cable between connector X10 on the VTA2001-A1 Voice Terminal Board and connector X205 of the right-most VTO2001-U2/U3 Option Module (24 Switches) mounted on the inner door.
2. Use ribbon cable jumpers to interconnect each of the installed VTO2001-U2/U3 modules in “daisy chain” fashion, as illustrated in Figure 9.

NOTE Instructions for wiring the VTO2001-U2/U3 Module to the VTO2004-U2/U3 Module and installing the A5Q00055918D End-of-Line termination are provided in Siemens Industry, Inc., Building Technologies Division, document number *A6V10370377 Installation Instructions for the Model VTO2004-U2/U3 Option Module (Microphone)*.

- If there is more than one remote microphone station in the system, an additional ribbon cable is installed in all the intermediate stations. That cable is installed between connector X205 on the Microphone Interface Board (MIB) which is located on top of the microphone module and connector X9 on the terminal board (see Figure 10). This cable continues the CAN bus “daisy chain” to the next station in the system. If instead there is only one remote microphone station in the system or the microphone station is the end station in a multi-station system, the cable is not used. All that is installed is an A5Q00055918D End-of-Line terminator in connector X205 of the MIB.

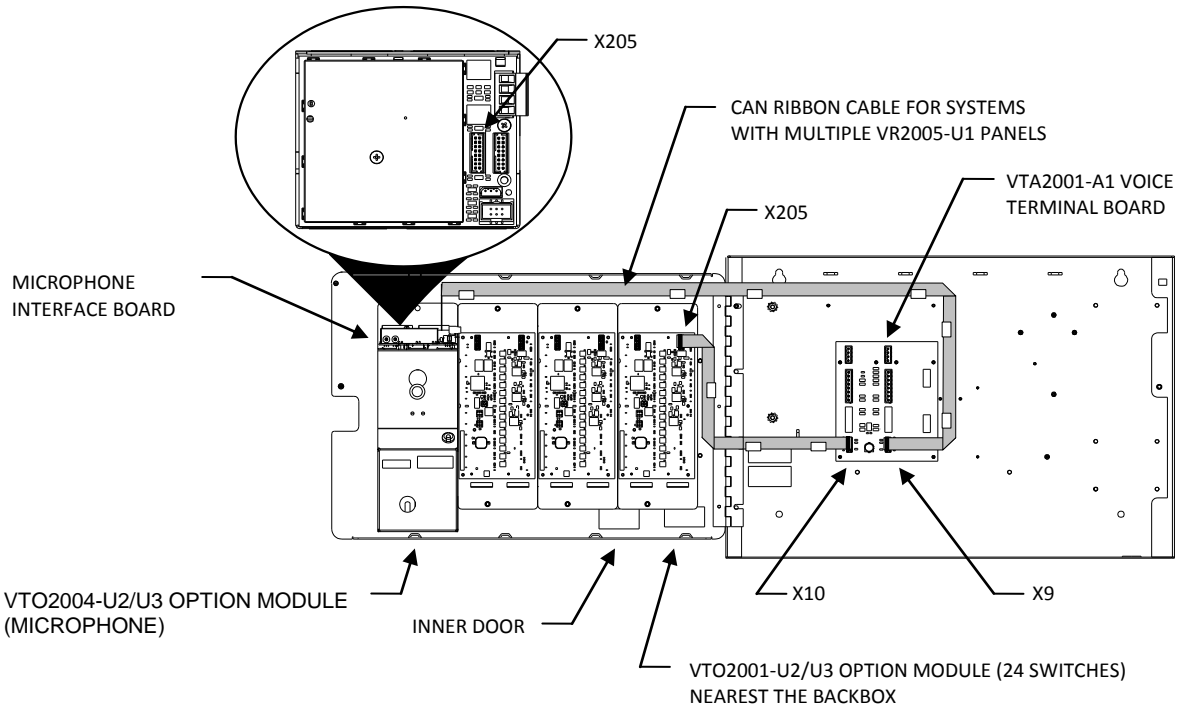

Figure 10

Wiring the VTO2001-U2/U3 Modules in an intermediate VR2005-U1 Remote Microphone Station

ELECTRICAL RATINGS

VTO2001-U2/U3 Option Module (24 Switches)		
Input	Voltage	24VDC
	Current	Standby: 17mA (no LED active) Active: 17mA + 2.6 mA per each LED* 143 mA, max
		*48 LEDs, total

'This page has been left intentionally blank'

'This page has been left intentionally blank'

'This page has been left intentionally blank'

Siemens Industry, Inc.
Building Technologies Division
Florham Park, NJ

Siemens Canada Limited
Building Technologies Division
2 Kenview Boulevard
Brampton, Ontario L6T 5E4 Canada

Document ID: A6V10370342_en--_a
P/N: A5Q00052627