

Installation Instructions

PMI-UK2

Upgrade Kit For Rev.1 to Rev.4 PMIs

INTRODUCTION

The **SIEMENS** PMI-UK2 provides the user with the materials to upgrade a Revision 4 or earlier PMI to a Revision 8 PMI.

The PMI-UK2 includes one of each of the following:

- XLS Retrofit Memory Card
- PMI BootROM IC Rev. 5.03
- SIMM Memory Expansion Chip
- PLCC Extraction Tool
- Foam Cube
- Installation Instructions



An additional upgrade kit, GPMI-UK, P/N 500-650066, is required to upgrade a Revision 5 PMI to a Global PMI.

PRE-INSTALLATION



Remove all system power before installation, first battery then AC. (To power up, connect the AC first, then the battery.)

1. Remove the battery connection to the system.
2. Remove the power connection to the system.
3. Remove all other connections to the PMI.
4. Remove the rear plastic cover from the PMI. It is held in place by four mounting screws. The location of the screws is marked A in Figure 1. Place the screws to one side.

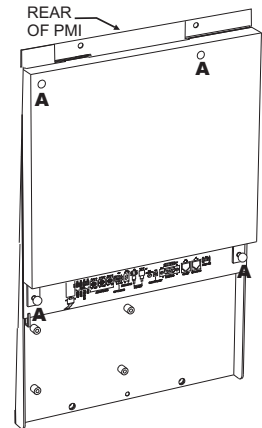

Figure 1
Rear Of PMI

INSTALLATION

Preparing and Installing The XLS Retrofit Memory Card:

1. Carefully remove the memory card from the anti-static bag.
2. Insert the Retrofit Memory Card into the PCMCIA slot of your Zeus laptop. Log on to Zeus 8.00.0023. Then, using the Build>Transfer>Firmware To PCMCIA option, transfer the following files to the memory card (Refer to Figure 2):

ChildBoot05_01_0004.BIN
PMI08.01.0010.BIN

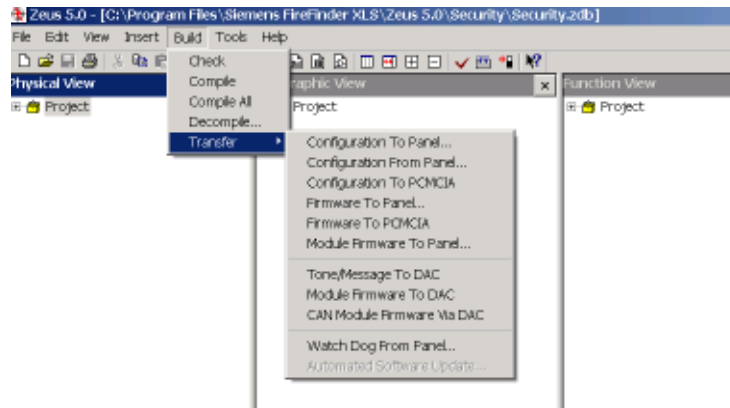

Figure 2
Zeus 5.0 Transfer Menu

3. Locate the PCMCIA slot (P4) in the upper right corner of the rear of the PMI. (Refer to Figure 3.)
4. Insert the XLS Retrofit Memory Card with the label facing out and the pinholes facing down. Ensure that the adapter is fully and evenly seated in the slot. Do not bend the slot forward during insertion.

Installing The PMI BootROM IC:



The Boot ROM is a static sensitive device. Observe precautions for handling static sensitive devices.

1. Locate the IC to be upgraded on the PMI (U6 - Refer to Figure 3.) The IC has a label attached to the top surface that indicates the IC number and the software revision currently installed. Make certain that the IC number on the module corresponds to the IC number in the upgrade kit.
2. Note where and how the IC is positioned on the PMI module. Be sure to note the position of the notch in one corner of the IC.
3. Remove the existing IC using the PLCC extraction tool provided in the upgrade kit. Insert the tool into the slots present in 2 of the corners of the chip mounting. The tool will lift and remove the chip.



Do not attempt to use any other type of tool. Damage to the socket can result.

4. Carefully remove the BootROM IC from the anti-static bag.
5. Notice that one corner of the BootROM is cut at a diagonal. This corner must be placed into the upper left-hand corner of the socket where it is marked with pin numbers 6 and 7. Place the new Boot ROM loosely into the socket. Press it firmly into place by applying pressure in the center of the Boot ROM. Once fully seated, the Boot ROM will be flush with the top of the socket.



If the Rev. 5 IC is not installed in the same location and position/orientation, severe damage to the module can occur.

6. Retain the previous IC until successful completion of the system upgrade.

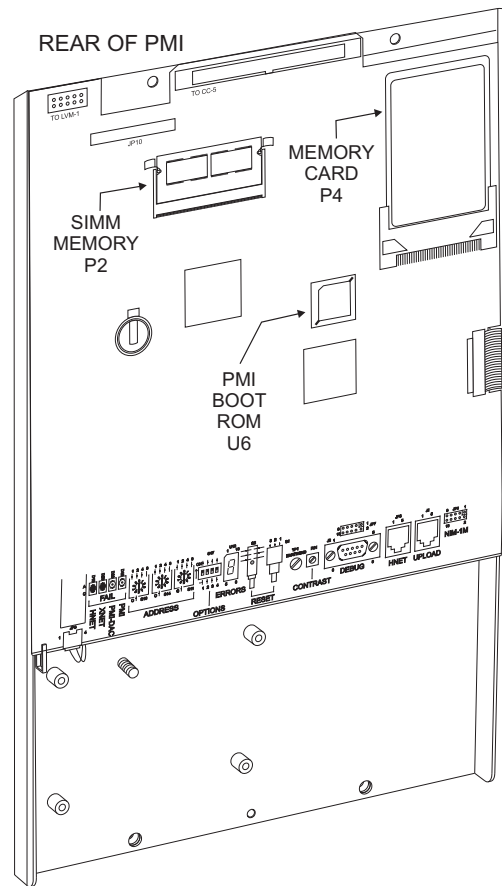

Figure 3
Location Of PCMCIA Card, BootROM IC and SIMM Memory

Installing The SIMM Memory Expansion:



The SIMM is a static sensitive device. Observe precautions for handling static sensitive devices.

1. Locate the SIMM memory chip at P2. It is located directly to the right of RN5 and RN6. (Refer to Figure 3.) Note its position and orientation.
2. Push the metal retaining clips on either side of the SIMM to release the chip and slide the chip up to remove it.
3. Carefully remove the Rev. 5.03 SIMM from the anti-static bag.
4. Insert the new memory chip evenly, ensuring that the metal clips set into the notches in the corners of the chip.
5. Retain the previous memory chip until successful completion of the system upgrade.

Installing The PCMCIA Positioning Foam:

1. Peel the protective covering from the adhesive side of the foam cube.
2. Position the foam on the inside of the PMI rear cover as shown in Figure 4.
3. Press the foam firmly into place.
4. Replace the rear plastic cover and secure with the four mounting screws.

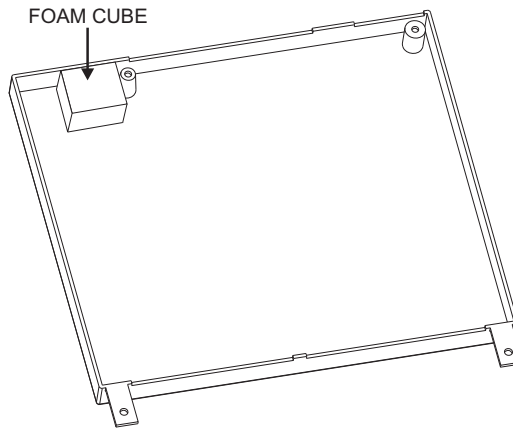

Figure 4
Installing The PCMCIA Positioning Foam

Reconnecting And Configuring The PMI:

1. Restore power/battery to the PMI in the firmware upgrade mode. To enter this mode, place DIP switch #2 on the options DIP switch (located at the bottom edge of the PMI) in the ON position. (Refer to Figure 5.)
2. Press the RESET button on the rear of the PMI.
3. After a short delay, the Status display will begin to show the version of the Boot ROM. First a small "r" will appear followed by the Boot ROM version number, e.g. r5.01.0004. Once this has begun the PMI firmware can be upgraded via Zeus.
4. Connect the programming cable to the UPLOAD port and install the firmware. As the firmware is being installed, the Status display will show an "L" which turns on and off at a slow rate.
5. Using the Zeus configuration tool, select "Build\Transfer\Firmware To Panel" and transfer the PCMCIALoader.bin file Version 05.01.0004 to the PMI.
6. Once completed, the Status display will show "d." Then use Zeus to transfer the desired MR5 configuration to the panel via the "Build\Transfer\Configuration To Panel" option.
7. After "d" is displayed, return DIP switch #2 to the OFF position.
8. Press the RESET button on the rear of the PMI. The PMI will now restart with the upgraded firmware.

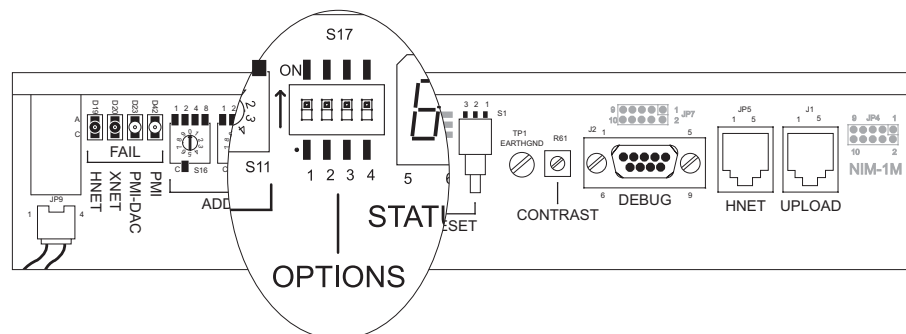

Figure 5
Locating Options DIP Switch On PMI